

# Hitachi Virtual Storage Platform G1000, G1500, and Virtual Storage Platform F1500

80-06-6x

---

## Hardware Guide

This document provides information about the system hardware components, mechanical, and environmental specifications for the VSP G1000, VSP G1500, and VSP F1500 storage systems.

© 2014, 2018 Hitachi, Ltd. All rights reserved.

No part of this publication may be reproduced or transmitted in any form or by any means, electronic or mechanical, including copying and recording, or stored in a database or retrieval system for commercial purposes without the express written permission of Hitachi, Ltd., or Hitachi Vantara Corporation (collectively "Hitachi"). Licensee may make copies of the Materials provided that any such copy is: (i) created as an essential step in utilization of the Software as licensed and is used in no other manner; or (ii) used for archival purposes. Licensee may not make any other copies of the Materials. "Materials" mean text, data, photographs, graphics, audio, video and documents.

Hitachi reserves the right to make changes to this Material at any time without notice and assumes no responsibility for its use. The Materials contain the most current information available at the time of publication.

Some of the features described in the Materials might not be currently available. Refer to the most recent product announcement for information about feature and product availability, or contact Hitachi Vantara Corporation at <https://support.hitachivantara.com/en-us/contact-us.html>.

**Notice:** Hitachi products and services can be ordered only under the terms and conditions of the applicable Hitachi agreements. The use of Hitachi products is governed by the terms of your agreements with Hitachi Vantara Corporation.

By using this software, you agree that you are responsible for:

1. Acquiring the relevant consents as may be required under local privacy laws or otherwise from authorized employees and other individuals; and
2. Verifying that your data continues to be held, retrieved, deleted, or otherwise processed in accordance with relevant laws.

**Notice on Export Controls.** The technical data and technology inherent in this Document may be subject to U.S. export control laws, including the U.S. Export Administration Act and its associated regulations, and may be subject to export or import regulations in other countries. Reader agrees to comply strictly with all such regulations and acknowledges that Reader has the responsibility to obtain licenses to export, re-export, or import the Document and any Compliant Products.

Hitachi and Lumada are trademarks or registered trademarks of Hitachi, Ltd., in the United States and other countries.

AIX, AS/400e, DB2, Domino, DS6000, DS8000, Enterprise Storage Server, eServer, FICON, FlashCopy, GDPS, HyperSwap, IBM, Lotus, MVS, OS/390, PowerHA, PowerPC, RS/6000, S/390, System z9, System z10, Tivoli, z/OS, z9, z10, z13, z14, z/VM, and z/VSE are registered trademarks or trademarks of International Business Machines Corporation.

Active Directory, ActiveX, Bing, Excel, Hyper-V, Internet Explorer, the Internet Explorer logo, Microsoft, the Microsoft Corporate Logo, MS-DOS, Outlook, PowerPoint, SharePoint, Silverlight, SmartScreen, SQL Server, Visual Basic, Visual C++, Visual Studio, Windows, the Windows logo, Windows Azure, Windows PowerShell, Windows Server, the Windows start button, and Windows Vista are registered trademarks or trademarks of Microsoft Corporation. Microsoft product screen shots are reprinted with permission from Microsoft Corporation.

All other trademarks, service marks, and company names in this document or website are properties of their respective owners.

Copyright and license information for third-party and open source software used in Hitachi Vantara products can be found at <https://www.hitachivantara.com/en-us/company/legal.html>.

---

# Contents

<b>Preface.....</b>	<b>8</b>
Safety and environmental information.....	8
Intended audience.....	8
Product version.....	8
Release notes.....	9
Changes in this revision.....	9
Related documents.....	9
Document conventions.....	9
Conventions for storage capacity values.....	11
Accessing product documentation.....	12
Getting help.....	12
Comments.....	12
<b>Chapter 1: VSP G1000, VSP G1500, and VSP F1500 overview.....</b>	<b>13</b>
System overview.....	13
Features.....	13
High performance.....	14
Scalability.....	15
Flexible connectivity.....	16
High reliability.....	17
High flexibility.....	17
Nondisruptive service and upgrades.....	19
High temperature mode .....	19
Economical and quiet.....	21
<b>Chapter 2: Storage system hardware overview.....</b>	<b>22</b>
Storage system configurations and model list.....	22
System controller chassis.....	34
Front-end directors.....	37
Supported connectors and protocols.....	39
Flexible front-end director installation.....	42
Supported speeds and cable lengths.....	45
Back-end director.....	46
Flexible back-end director installation.....	47
Drive chassis.....	47

Cache memory.....	53
Memory operation.....	55
Data protection.....	55
Cache capacity.....	55
Shared memory.....	56
Cache flash memory.....	60
Cache flash memory operation.....	60
Cache flash memory capacity.....	60
Service Processor.....	61
<b>Chapter 3: Hardware architecture.....</b>	<b>63</b>
VSP G1000, VSP G1500, and VSP F1500 RAID implementation.....	63
Array groups and RAID levels.....	64
RAID 1.....	64
RAID 5.....	66
RAID 6.....	68
LDEV striping across array groups.....	69
Control unit images, logical volume images, and logical units.....	71
CU images.....	71
Logical volume images.....	72
Logical units.....	72
Mainframe operations.....	72
Mainframe compatibility and functionality.....	72
Mainframe operating system support.....	73
Mainframe configuration.....	73
Open-systems operations.....	74
Open-systems compatibility and functionality.....	74
Open-systems host platform support.....	75
System configuration.....	75
Host modes and host mode options.....	76
Device Manager - Storage Navigator program.....	76
<b>Chapter 4: Site preparation specifications.....</b>	<b>78</b>
Responsibilities.....	78
Customer responsibilities.....	78
Hitachi Vantara responsibilities.....	79
Site preparation checklist.....	79
General site requirements.....	82
Equipment clearances.....	82
Equipment weight.....	82
System storage requirements.....	83
Grounding.....	83

Power connection.....	83
Data center requirements.....	84
Operational requirements.....	85
Third-party rack support for VSP G1000, VSP G1500, and VSP F1500 storage systems.....	85
Service clearance, floor cutout, and floor load rating.....	86
Single-rack configuration.....	86
Two-rack, single-controller configuration.....	88
Two-rack, dual-controller configuration.....	90
Three-rack, single-controller configuration.....	92
Three-rack, dual-controller configuration.....	94
Four-rack configuration - two controllers (center).....	96
Four-rack configuration - two controllers (left).....	98
Five-rack configuration.....	100
Six-rack configuration.....	102
Seven-rack configuration.....	104
<b>Chapter 5: Cable connection guidelines.....</b>	<b>107</b>
Port configurations.....	107
Power connection diagrams.....	108
UPS power connection.....	110
Data connection diagrams.....	111
Extended cable connections.....	115
<b>Chapter 6: Turning storage system power on and off.....</b>	<b>122</b>
Power control panel.....	122
System idle mode.....	124
Normal power on/off procedures.....	124
Power on procedures.....	125
Power off procedures.....	125
Emergency power off/on procedures.....	126
Turning off power to the storage system during an emergency.....	126
Turning on power to the storage system after an emergency shutdown....	127
<b>Chapter 7: VSP G1x00 and F1x00 batteries.....</b>	<b>128</b>
Battery backup operations.....	128
Cache backup batteries.....	129
Battery life.....	130
Storing the system.....	130
<b>Chapter 8: Troubleshooting the storage system.....</b>	<b>131</b>
Getting help.....	131
Solving problems.....	131

Service information messages.....	132
<b>Appendix A: Storage system specifications.....</b>	<b>134</b>
<b>Appendix B: Mechanical specifications.....</b>	<b>143</b>
<b>Appendix C: Electrical specifications.....</b>	<b>144</b>
<b>Appendix D: Environmental specifications.....</b>	<b>147</b>
<b>Appendix E: Component power consumption, heat output, and airflow.....</b>	<b>151</b>
<b>Appendix F: Power distribution units for Hitachi Universal V2 Rack .....</b>	<b>158</b>
Americas single-phase PDU 1P30A-8C13-3C19UL.P.....	158
Americas single-phase PDU 1P30A-15C13-3C19UL.P.....	159
Americas three-phase PDU 3P30A-8C13-3C19UL.P.....	159
Americas three-phase PDU 3P30A-15C13-3C19UL.P.....	160
Americas three-phase PDU 3P30A-24C13-6C19UL.P.....	161
APAC and EMEA single-phase PDU 1P32A-9C13-3C19CE.P.....	162
APAC and EMEA single-phase PDU 1P32A-18C13-3C19CE.P.....	163
APAC and EMEA three-phase PDU 3P16A-9C13-3C19CE.P.....	164
APAC and EMEA three-phase PDU 3P16A-15C13-3C19CE.P.....	165
APAC and EMEA three-phase PDU 3P32A-24C13-6C19CE.P.....	166
<b>Appendix G: Safety requirements.....</b>	<b>168</b>
General safety guidelines.....	168
Work safety guidelines.....	169
Warning about moving parts.....	169
Electrical safety guidelines.....	170
<b>Appendix H: Regulatory specifications.....</b>	<b>171</b>
Regulatory compliance.....	171
US FCC Notice.....	174
Electronic emissions testing.....	174
European Declaration of Conformity.....	174
Notice of export controls.....	175
China RoHS.....	175
Hazardous and toxic substances.....	175
Disposal.....	176
Recycling.....	176
Electronic emissions certificates.....	176
FIPS 140-2 Consolidated Validation Certificate.....	180

**Glossary..... 181**

---

## Preface

This guide provides technical information about the Hitachi Virtual Storage Platform 5000 series storage systems.

Please read this document carefully to understand how to use this product, and maintain a copy for reference purposes.

## Safety and environmental information



**Caution:** Before operating or working on the Hitachi Virtual Storage Platform G1x00, and the Hitachi Virtual Storage Platform F1500 storage systems, read the safety and environmental information in [Safety requirements \(on page 168\)](#) and [Regulatory Compliance \(on page 171\)](#).

## Intended audience

This document is intended for system administrators, Hitachi Vantara representatives, and authorized service providers who install, configure, and operate VSP G1000, VSP G1500, and VSP F1500 storage systems.

Readers of this document should be familiar with the following:

- Data processing and RAID storage systems and their basic functions.
- The VSP G1000, VSP G1500, and VSP F1500 storage systems and the *Product Overview*.
- The Storage Navigator software.
- The concepts and functionality of storage provisioning operations in the use of Hitachi Dynamic Provisioning, Hitachi Dynamic Tiering software, and Hitachi Data Retention Utility.

## Product version

This document revision applies to storage system microcode version 80-06-6x or later.



## Release notes

Read the release notes before installing and using this product. They may contain requirements or restrictions that are not fully described in this document or updates or corrections to this document. Release notes are available on Hitachi Vantara Support Connect: <https://knowledge.hitachivantara.com/Documents>.

## Changes in this revision

- Added support for ROHS compliant primary controller chassis and additional service processor.
- Added additional support for 256GB cache flash memory module.

## Related documents

The following documents are referenced in this guide or contain more information about the features described in this document.

Hitachi Virtual Storage Platform G1x00, and Hitachi Virtual Storage Platform F1500 documents:

- *Product Overview*, MK-92RD8051
- *System Administrator Guide*, MK-92RD8016
- *Provisioning Guide for Mainframe Systems*, MK-92RD8013
- *Provisioning Guide for Open Systems*, MK-92RD8014
- *Hitachi Universal V2 Rack Reference Guide*, MK-94HM8035
- *Mainframe Host Attachment and Operations Guide*, MK-96RD645
- *Open-Systems Host Attachment Guide*, MK-90RD7037
- *Hitachi Alert Notification Guide*, MK-92RD8015

For a list of all documents related to the Hitachi Virtual Storage Platform G1x00 and Hitachi Virtual Storage Platform F1500 storage systems, see the *Product Overview*.



## Document conventions

This document uses the following typographic conventions:

Convention	Description
<b>Bold</b>	<ul style="list-style-type: none"> <li>Indicates text in a window, including window titles, menus, menu options, buttons, fields, and labels. Example: Click <b>OK</b>.</li> <li>Indicates emphasized words in list items.</li> </ul>
<i>Italic</i>	<ul style="list-style-type: none"> <li>Indicates a document title or emphasized words in text.</li> <li>Indicates a variable, which is a placeholder for actual text provided by the user or for output by the system. Example: <code>pairdisplay -g group</code></li> </ul> <p>(For exceptions to this convention for variables, see the entry for angle brackets.)</p>
Monospace	Indicates text that is displayed on screen or entered by the user. Example: <code>pairdisplay -g oradb</code>
< > angle brackets	Indicates variables in the following scenarios: <ul style="list-style-type: none"> <li>Variables are not clearly separated from the surrounding text or from other variables. Example: <code>Status-&lt;report-name&gt;&lt;file-version&gt;.csv</code></li> <li>Variables in headings.</li> </ul>
[ ] square brackets	Indicates optional values. Example: [ a   b ] indicates that you can choose a, b, or nothing.
{ } braces	Indicates required or expected values. Example: { a   b } indicates that you must choose either a or b.
vertical bar	Indicates that you have a choice between two or more options or arguments. Examples: [ a   b ] indicates that you can choose a, b, or nothing. { a   b } indicates that you must choose either a or b.

This document uses the following icons to draw attention to information:

Icon	Label	Description
	Note	Calls attention to important or additional information.

Icon	Label	Description
	Tip	Provides helpful information, guidelines, or suggestions for performing tasks more effectively.
	Caution	Warns the user of adverse conditions and/or consequences (for example, disruptive operations, data loss, or a system crash).
	WARNING	Warns the user of a hazardous situation which, if not avoided, could result in death or serious injury.

## Conventions for storage capacity values

Physical storage capacity values (for example, disk drive capacity) are calculated based on the following values:

Physical capacity unit	Value
1 kilobyte (KB)	1,000 ( $10^3$ ) bytes
1 megabyte (MB)	1,000 KB or $1,000^2$ bytes
1 gigabyte (GB)	1,000 MB or $1,000^3$ bytes
1 terabyte (TB)	1,000 GB or $1,000^4$ bytes
1 petabyte (PB)	1,000 TB or $1,000^5$ bytes
1 exabyte (EB)	1,000 PB or $1,000^6$ bytes

Logical capacity values (for example, logical device capacity, cache memory capacity) are calculated based on the following values:

Logical capacity unit	Value
1 block	512 bytes
1 cylinder	Mainframe: 870 KB Open-systems: <ul style="list-style-type: none"> <li>▪ OPEN-V: 960 KB</li> <li>▪ Others: 720 KB</li> </ul>
1 KB	$1,024 (2^{10})$ bytes

Logical capacity unit	Value
1 MB	1,024 KB or 1,024 <sup>2</sup> bytes
1 GB	1,024 MB or 1,024 <sup>3</sup> bytes
1 TB	1,024 GB or 1,024 <sup>4</sup> bytes
1 PB	1,024 TB or 1,024 <sup>5</sup> bytes
1 EB	1,024 PB or 1,024 <sup>6</sup> bytes

## Accessing product documentation

Product user documentation is available on Hitachi Vantara Support Connect: <https://knowledge.hitachivantara.com/Documents>. Check this site for the most current documentation, including important updates that may have been made after the release of the product.

## Getting help

[Hitachi Vantara Support Connect](#) is the destination for technical support of products and solutions sold by Hitachi Vantara. To contact technical support, log on to Hitachi Vantara Support Connect for contact information: [https://support.hitachivantara.com/en\\_us/contact-us.html](https://support.hitachivantara.com/en_us/contact-us.html).

[Hitachi Vantara Community](#) is a global online community for Hitachi Vantara customers, partners, independent software vendors, employees, and prospects. It is the destination to get answers, discover insights, and make connections. **Join the conversation today!** Go to [community.hitachivantara.com](https://community.hitachivantara.com), register, and complete your profile.

## Comments

Please send us your comments on this document to [doc.comments@hitachivantara.com](mailto:doc.comments@hitachivantara.com). Include the document title and number, including the revision level (for example, -07), and refer to specific sections and paragraphs whenever possible. All comments become the property of Hitachi Vantara Corporation.

**Thank you!**

---

# Chapter 1: VSP G1000, VSP G1500, and VSP F1500 overview

The following describes the hardware components of the VSP G1000, VSP G1500, and VSP F1500 storage systems.

## System overview

The VSP G1000, VSP G1500, and VSP F1500 are high-capacity, high-performance, unified block and file enterprise storage systems that offer a wide range of storage and data services, software, logical partitioning, and unified data replication across heterogeneous storage systems.

## Features

The VSP G1000, VSP G1500, and VSP F1500 storage systems include state-of-the-art advances in hardware technology that improve reliability, serviceability, and accessibility to drives and other components when maintenance is required.

- VSP F1500 all-flash array is configured exclusively with the latest generation of flash module drives (FMDs) to provide performance optimized for intense I/O operations. Designed for flash-first, high-performance workloads and leveraging Hitachi SVOS-based deduplication and compression, VSP F1500 offers up to five times greater ROI with unified support for SAN, NAS, and mainframe workloads.
  - Accelerated flash architecture delivers consistent, low-latency IOPS at scale.
  - Adaptive flash management distributes writes and rebalances load over time.
  - Hitachi FMDs deliver enterprise performance with superior functionality and greater cost value.
  - Hitachi FMD-HDE (high-density with encryption) drives provide high-density storage capacities with accelerated compression and hardware-embedded encryption capabilities.
- The VSP G1500 and VSP F1500 are equipped with new virtual storage directors (VSD). The VSD uses the latest generation of Intel Xenon 2.3-GHz 8-core microprocessor to efficiently manage the front-end directors, back-end directors, PCI Express interface, local memory, and communication between the service processor.
- Hitachi Accelerated Flash FMD DC2 storage offers a patented data-center-class design and rack-optimized form factor that delivers more than 8 PB per system. The FMD DC2 supports a sustained performance of 100,000 8K I/O per second, per device, with low and consistent response time.

- The latest 2.5-inch and 3.5-inch 6 Gbps SAS drives support lower power consumption and higher density per rack with up to 2,304 drives in six 19-inch standard racks. For more information about drive specifications, see [Storage system specifications \(on page 134\)](#). For information about Hitachi racks, refer to the *Hitachi Universal V2 Rack Reference Guide*.
- Hitachi NAS Platform hardware-accelerated network protocols support up to 2 Gbps throughput for sequential workloads and up to 1.2 million NFS operations per second.
- Efficient caching makes up to 2 TB global cache dynamically accessible by all connected hosts and Hitachi NAS Platform nodes.
- The HNAS file module provides primary data deduplication using hardware-based SHA-256 calculation engines. This module achieves up to 90% capacity savings while maintaining high performance.
- When each controller is housed in a separate rack, the two controller racks can be placed up to 100 meters apart. In addition, the drive racks attached to a controller rack can be placed up to 100 meters from the controller rack. This enables maximum flexibility to optimize data center space usage and provides ease of access for operation and maintenance. See the detailed description of this feature and the cable diagrams in [Long cable connections \(on page 115\)](#).
- Expandable cache memory (up to 2 TB per 2-controller system).
- Nondisruptive migration is available as a service from Hitachi Vantara representatives as well as by purchasing an optional software license for customer implementation. Best practice is to use the nondisruptive migration planning service offered by Hitachi Vantara Global Solution Services (GSS). See [Nondisruptive service and upgrades \(on page 19\)](#).
- High temperature mode is a licensed feature that allows the storage system to operate at either standard temperature (60.8°F to 89.6°F / 16°C to 32°C) or higher temperatures (60.8°F to 104°F / 16°C to 40°C) in a data center, saving energy and cooling costs. See [high temperature mode \(on page 19\)](#).

## High performance

Hitachi Vantara offers the highest performance storage systems for the enterprise-class segment. The high-performance storage system enables consolidation and real-time applications, a wide range of storage and data services, software, logical partitioning, along with simplified and unified data replication across heterogeneous storage systems. Its large-scale, enterprise class virtualization layer, combined with Hitachi Dynamic Tiering and thin provisioning software, allows you to consolidate internal and external storage into one pool.

The storage system includes several features that improve system performance:

- Hitachi Accelerated Flash module drives that support ultra-high I/O rates and ultra-low latency.
- Solid-state drives with high-speed response.

- Device Manager - Storage Navigator and Hitachi Ops Center Administrator provide integrated data and storage management to ensure high-speed data transfer between the back-end directors and small form-factor (SFF) or large form-factor (LFF) drives at 6 Gbps using a SAS interface.
- Ability to scale and upgrade system performance.
- Compression functionality reduces the size of stored data by encoding without reducing the amount of data.
- Deduplication functionality deletes the duplicated data while keeping the data in a single location when the same data is written to different addresses within the same pool.
- Disk drives operating at 7,200, 10,000, or 15,000 RPM.

## Scalability

The storage systems offer an entirely new type of scalable and adaptable integrated active-active architecture that supports integrated management. Hitachi storage systems can be configured in numerous ways to meet performance and storage requirements.

### Scalable system performance

System performance can be optimized according to the needs of the user and can be easily upgraded (in small or large increments) as storage needs increase. The following table shows the supported configurations.

**Table 1 System performance configurations**

Number of controllers	Number of VSD pairs / CPU cores <sup>1</sup>	Cache size <sup>2</sup>
1	min = 1 (16 cores) max = 4 (64 cores)	min = 64 GB <sup>3</sup> max = 1 TB
2	min = 2 (32 cores) max = 8 (128 cores)	min = 64 GB per system (32 GB per controller) <sup>3</sup> max = 2 TB
<p><b>Notes:</b></p> <p>1. A VSD pair consists of two VSD blades. Each VSD contains one 8-core processor.</p> <p>2. Cache memory modules can be either 16 GB or 32 GB, but only one memory module size can be used in a system.</p> <p>3. HDS minimum cache per system is 64 GB whether the system contains one or two controllers.</p>		

### Scalable storage capacity

- The minimum configuration is a single rack with one controller chassis in a diskless configuration.
- A small system can be a single rack with one controller chassis and up to two drive chassis or flash drive chassis.
- A mid-sized system can be three racks with one controller chassis and a maximum of eight combined LFF or SFF drive chassis and up to two flash module drive (FMD) chassis.
- For combined block and file storage systems, the maximum configuration depends on how many HNAS servers and switches are installed. Consult your authorized representative for examples of available configurations.
- Maximum storage capacity:
  - The storage systems can be configured up to 65,280 logical volumes.
  - Configurable up to 2,304 SFF disk drives with a maximum physical disk capacity of approximately 5.3 PB (using 2.4 TB HDDs) or 34.7 PB (using 15 TB SSDs) per storage system, or up to 1,152 LFF disk drives with a maximum physical disk capacity of approximately 6.8 PB (using 6 TB HDDs) per storage system.
  - A drive intermix configuration can be configured up to 576 flash module drives with a maximum physical capacity of 8.1 PB (using 14 TB FMDs) per storage system.

### Flexible connectivity

The storage system supports connectivity to mainframe hosts through FICON<sup>®</sup> front-end directors and to open servers via Fibre Channel, iSCSI, and Fibre Channel over Ethernet (FCoE) front-end directors. The storage system can be configured with a combination of all of these front-end directors to support both mainframe hosts and open servers simultaneously.

For details about host connectivity and OS support, see [https://support.hds.com/en\\_us/interoperability.html](https://support.hds.com/en_us/interoperability.html).



## High reliability

The storage system includes the following features to enhance reliability:

- **Multiple RAID configurations:** The system supports RAID 6 (6D+2P and 14D+2P), RAID 5 (3D+1P and 7D+1P), and RAID 1 (2D+2D and 4D+4D).
- **Duplicate hardware:** Every module in the controller chassis and drive chassis is configured in redundant pairs so that if any module fails, the redundant module takes over until the failed component is replaced. The redundant hardware includes power supplies, VSD pairs, cache path controllers, front-end directors, back-end directors, and drives. If one of these hardware components fails, the storage system continues normal operation with zero data loss.
- **Protection from power failures:** The storage systems have dual-power feeds. In the event of a partial power loss on one of the feeds, the system operates normally on the alternate feed until full power is restored. In the event of a full power loss, the cache backup modules maintain the availability of the cache contents for 32 minutes while the system copies the system configuration information and all data in the cache to a cache flash drive (SSD).

## High flexibility

The storage systems are available in several configurations, from a small single rack, diskless system to a large six-rack system that includes two controller chassis, up to 2,304 SFF drives, up to 1,152 LFF drives, up to 384 SSDs (per controller in a standard performance back-end configuration) or 1,152 SSDs (per controller in a high-performance back-end configuration), up to 576 flash module drives, and a total of 2 TB cache. The systems can be easily reconfigured for more storage capacity.

The storage systems support block-only, file-only, and unified (block and file) configurations in open and mainframe environments. Unified systems contain Hitachi Network Attached Storage servers and switches in addition to the block controller and storage drives.

## Typical system configurations

The storage systems can be configured to meet a variety of storage needs, with the following typical configurations based on customer use-cases:

- **Tiered storage:** A storage system configured for tiered storage consists of multiple drive types, including high-performance flash module drives for fast data access, medium performance and capacity drives for most storage needs, and maximum capacity drives for data warehousing, all in one system. A tiered storage system can be configured with FMDs (flash module drives), SSDs (solid state drives), SAS drives (SFF or LFF), and high-capacity LFF drives. Software applications such as Dynamic Tiering allocate data to the appropriate drives based on frequency of access.
- **Maximum performance:** A storage system configured with only flash module drives delivers maximum performance. This two-controller system can contain 12 FMD chassis with a total of 576 FMDs. This system is designed for an online retail site where customers expect fast access to multiple images, or a hospital medical imaging system where physicians need immediate access to 3D CAT or MRI images.
- **Maximum storage capacity:** A storage system containing 12 LFF chassis with a total of 1152 LFF drives provides the maximum storage capacity. This system configuration with less priority for high-speed access is ideally suited for use as a data warehouse for medical or insurance records.

## Software applications

The storage systems provide the foundation for matching application requirements to different classes of storage and delivering critical services, including:

- Business continuity services
- Content management services (search, indexing)
- Thin provisioning
- Dynamic Tiering
- High availability
- Security services
- I/O load balancing
- Data classification
- File management services

## Nondisruptive service and upgrades

The storage systems are designed specifically to avoid any interruptions during normal operations while servicing or upgrading the system components.

- Main components can be “hot-swapped” (added, removed, or replaced without disruption) during normal operation. These include every module in the controller chassis and the drive chassis, such as power supplies, virtual storage directors, front-end directors, and back-end directors, cache and cache backup modules, SVPs, and drives.
- A service processor (SVP) mounted in the controller chassis monitors the operating condition of the storage system. Connecting the SVP with a service center allows authorized service personnel to manage the system remotely.
- An online, nondisruptive upgrade of the Storage Virtualization Operating Systems (SVOS) can run during normal operation without shutting down or restarting the storage system.
- Optional Migration Enablement Service (includes pilot migration) is available to jump-start self-service migration. For complex, large-scale, heterogeneous, and remote replication data center environments, nondisruptive migration service from Hitachi Global Solution Services (GSS) is required. Contact your HDS authorized sales or service representative for more information.

## High temperature mode

High temperature mode is a feature that allows the storage system to operate at standard temperature (60.8°F to 89.6°F / 16°C to 32°C) or higher temperatures (60.8°F to 104°F / 16°C to 40°C), saving energy and cooling costs. Temperature sensors at the air inlets in the primary microprocessor blades measure the ambient air temperature.

### High temperature mode window

High temperature mode is set through the **Edit High Temperature Mode** window in the Device Manager - Storage Navigator GUI. The window also displays alerts when the ambient air temperature exceeds the preset limits.

- In standard temperature mode, a temperature alert (SIM) appears when the temperature in the storage system exceeds 89.6°F / 32°C.
- In high temperature mode, the temperature alert (SIM) appears when the temperature in the storage system exceeds 104°F / 40°C.

### System life

The lifetime of the system is five years when operating in the standard temperature mode. This lifetime is reduced when operating the system in high temperature mode, even if you change the system to standard temperature mode later.

### Cache flash memory battery life

When high temperature mode is enabled, the cache flash memory battery life is reduced to two-thirds of the battery life when high temperature mode is enabled.

Example 1: A new cache flash memory battery has three years of usable life when operated in a standard temperature environment. If you enable high temperature mode when the battery is new, the battery life will be reduced to two years.

Example 2: The storage system is used for two years at normal temperature mode. The cache battery has one year of usable life remaining at that time. If you enable high temperature mode, the life of the battery is reduced to eight months.

### Cache flash memory battery date

When high temperature mode is enabled, the battery replacement notice displays one year earlier than when high temperature mode is disabled.

After high temperature mode is enabled, the date of the battery replacement notice cannot be changed back to normal, even if high temperature mode is disabled. When high temperature mode is enabled, a confirmation message appears.



**Caution:** Important information about using high temperature mode.

See the *System Administrator Guide* for additional information.

- **Notify Technical Support:** Before enabling high temperature mode, contact Hitachi Vantara Support at [https://support.hds.com/en\\_us/contact-us.html](https://support.hds.com/en_us/contact-us.html) for updates or additional information besides the following notes.
- **Guidelines for operating with flash module drives in high temperature mode:**
  - Do not enable high temperature mode if the system contains flash module drives (FMDs) from an earlier generation (prior to Hitachi Accelerated Flash FMD DC2 drives). The early generation FMDs cannot operate in high temperature mode. Only enable high temperature mode with Hitachi Accelerated Flash FMD DC2 drives.
  - Do not enable high temperature mode if the system contains a combination of early and current generation FMDs.
- **Operating altitude:** Because thinner air does not provide sufficient cooling, do not enable high temperature mode if the system is located above 4920 ft / 1,500 m above sea level. A storage system can operate up to 9842 ft / 3,000 m above sea level in standard temperature mode.
- **System noise:** When the storage system is used in a high temperature environment near 104°F / 40°C, the fans operate at high speed, increasing system noise. See [Environmental specifications \(on page 147\)](#) for detailed information.

### Temperature measurement

Ambient air temperature is measured by a sensor in the cooling air inlet on each module in the primary VSD pair on each controller.

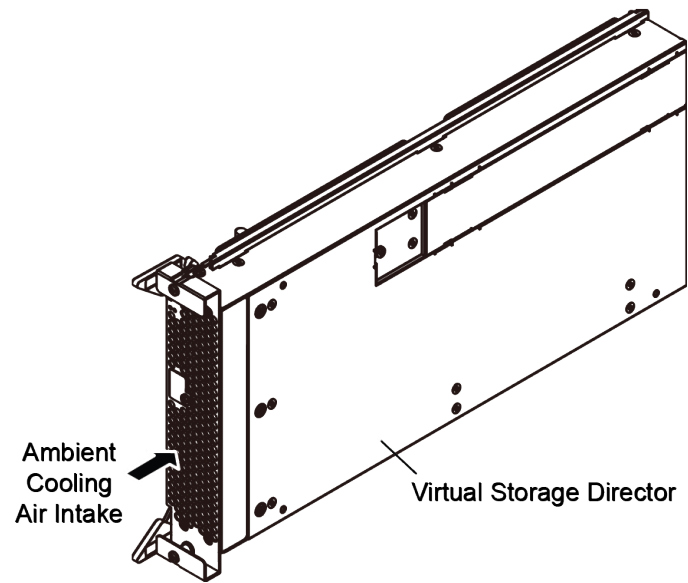

## **Economical and quiet**

The storage systems qualify as ENERGY STAR® products and meet specifications for data center storage. For more information, visit <http://www.energystar.gov/productfinder/product/certified-data-center-storage/details/2252003>.

---

## Chapter 2: Storage system hardware overview

The VSP G1x00 and VSP F1500 storage systems can be configured with one or two controller chassis and up to 12 drive chassis that contain the drives. A controller chassis contains the control logic, processors, memory, and interfaces to the drive chassis and the host servers. A drive chassis contains drives, power supplies, and the interface circuitry that connects it to the controller.

The controller rack contains the controller chassis and up to two drive chassis. Additional racks can contain an intermix of 16U SFF or LFF drive chassis and/or 8U flash drive chassis as well as one or two Hitachi NAS (HNAS) file system servers. When the controllers of a two-controller system are housed in separate racks, the two controller racks can be placed up to 100 meters apart. In addition, the drive racks attached to a controller rack can be placed up to 100 meters from the controller rack.

The VSP G1x00 storage systems support the latest hard disk drives (HDDs), solid-state drives (SSDs), and flash module drives (FMDs). The drives are installed into a specific drive chassis according to the drive type. The VSP G1x00 also support a *diskless* configuration (without drive chassis, all external storage).

The VSP F1500 all-flash array is equipped with advanced high-density FMDs that provide up to 4M IOPS and 40 PB of capacity for multi-workload consolidation.

### Storage system configurations and model list

The following section describes the storage system configurations, models, and components.

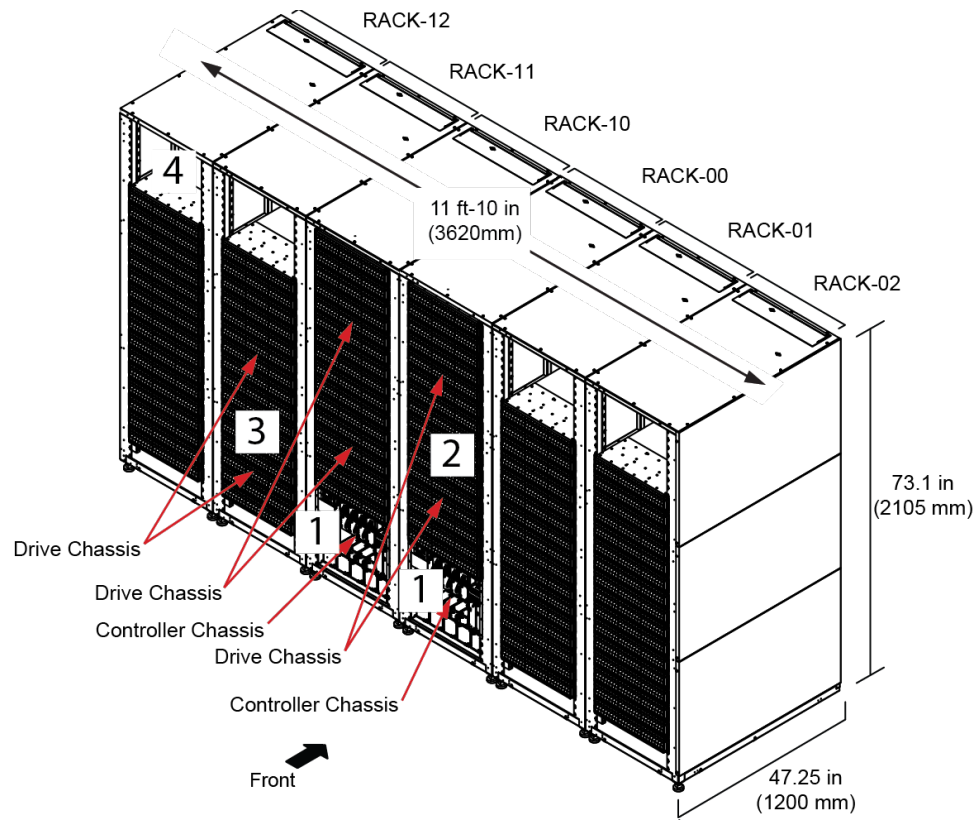

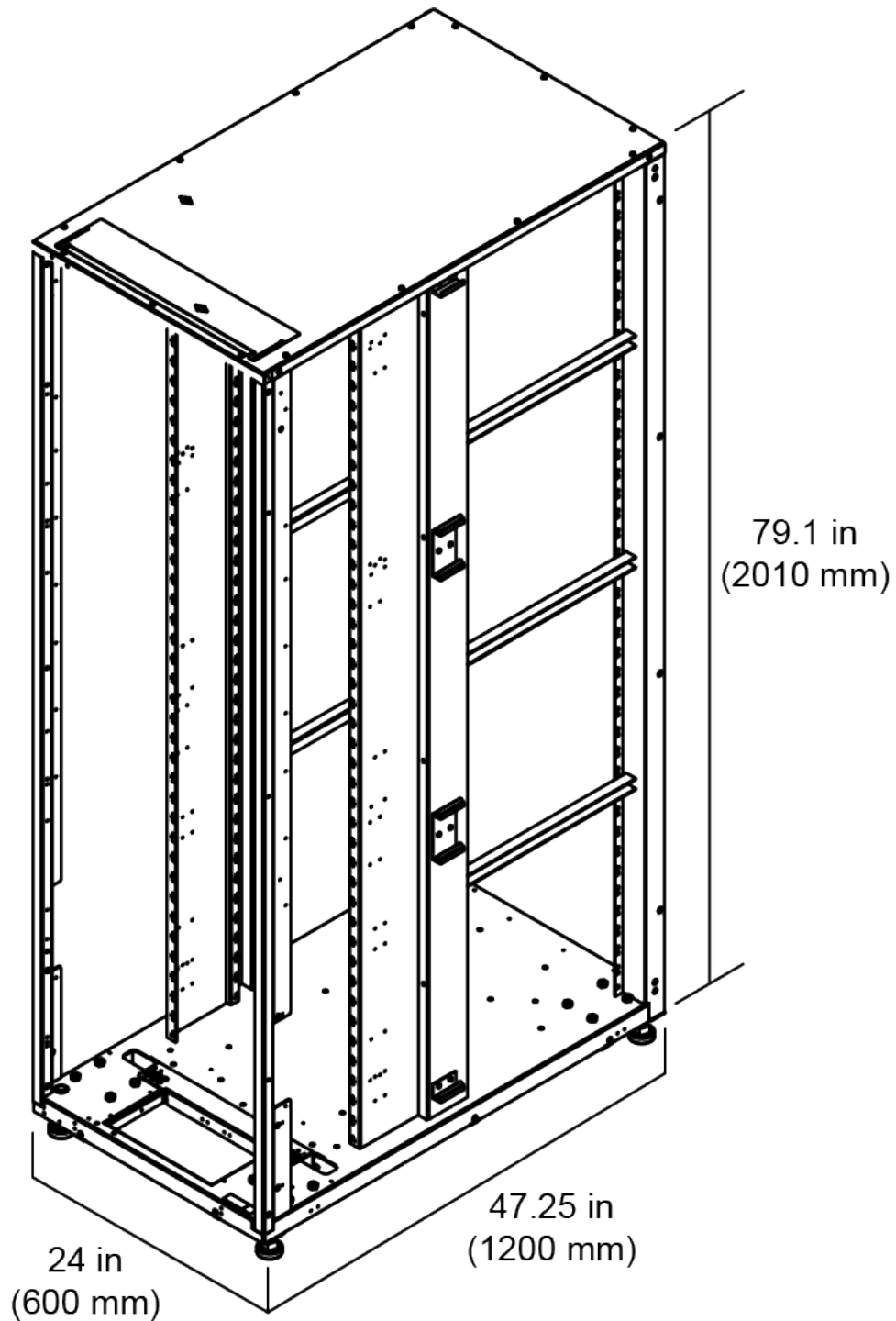

**Note:**

The illustration shown is only an example. The storage system provides flexibility for placing the controller and drive chassis within the racks. For more information about system configurations, contact your sales account representative.



Item	Description
1	10U controller chassis
2	(Optional) maximum of twelve 8U, FMD chassis
3	16U SFF or LFF drive chassis
4	8U space

**Table 2 Supported block module components**

Chassis	Description	Maximum chassis / drives per system	
		Single-controller system	Two-controller system
Controller	10U x 1 controller	1	2
SFF	16U x 192 2.5-inch HDDs	6 / 1,152	12 / 2,304
LFF	16U x 96 3.5-inch HDDs	6 / 576	12 / 1152
FMD	8U x 48 FMDs	6 / 288	12 / 576
SFF / LFF	SSDs	192 <sup>1</sup> 1,152 <sup>2</sup>	384 <sup>1</sup> 2,304 <sup>2</sup>
<sup>1</sup> Maximum number in a standard performance configuration. <sup>2</sup> Maximum number in a high-performance configuration.			

**Table 3 Supported minimum configuration options**

Number of VSD pairs	1	2 or 3	4	5	6 or 7	8
Number of controller chassis	1	1	1	2	2	2
Minimum cache memory (GB)	64	64	64	64	128	128
Cache backup kit	1	1	1	1	2	2
Front-end directors	1	1	1	1	1	1
Back-end directors	0	0	0	0	0	0
Number of racks	1	1	1	1 <sup>1</sup>	1 <sup>1</sup>	1 <sup>1</sup>

Number of VSD pairs	1	2 or 3	4	5	6 or 7	8
Drive chassis (SFF/LFF/FMD)	Optional	Optional	Optional	Optional	Optional	Optional
<sup>1</sup> Assumes both controllers are housed in a single rack. Two separate racks are required if the controllers are separately housed.						

### Model number list

The list provides the parts description number for each storage system model.

Table 4 Model number list

Component	Model number			
	VSP G1000	VSP G1500 (upgrade from VSP G1000 to G1500)	VSP G1500	VSP F1500
Primary Controller Chassis	DKC-810I-CBXA/ DKC-810I-CBXAC	DKC-810I-CBXA/ DKC-810I-CBXAC	DKC-810I-CBXE/ DKC810I-CBXET	DKC-810I-CBXE/ DKC810I-CBXET
Second Controller Chassis	DKC-810I-CBXB	DKC810I-CBXB	DKC-810I-CBXF	DKC-810I-CBXF
Controller Chassis Bezel	DKC-F810I-BCH	DKC-F810I-BCH	DKC-F810I-BCH	DKC-F810I-BCH
Badge for bezel	5557156-001	N/A	5562191-001	5562488-001
DKC Power Cord Kit (USA)	DKC-F810I-PLUC	DKC-F810I-PLUC	DKC-F810I-PLUC	DKC-F810I-PLUC
DKC Power Cord Kit (EU)	DKC-F810I-PLEC	DKC-F810I-PLEC	DKC-F810I-PLEC	DKC-F810I-PLEC
DKC Power Cord Kit (China)	DKC-F810I-PLCC	DKC-F810I-PLCC	DKC-F810I-PLCC	DKC-F810I-PLCC
LFF Drive Chassis	DKC-F810I-UBX/ DKC-F810I-UBXC	DKC-F810I-UBX/ DKC-F810I-UBXC	DKC-F810I-UBXC	N/A
SFF Drive Chassis	DKC-F810I-SBX/ DKC-F810I-SBXC	DKC-F810I-SBX/ DKC-F810I-SBXC	DKC-F810I-SBXC	DKC-F810I-SBXC
Drive Chassis Bezel	DKC-F810I-BUH	DKC-F810I-BUH	DKC-F810I-BUH	DKC-F810I-BUH
DKU Power Cord Kit (USA)	DKC-F810I-PHUC	DKC-F810I-PHUC	DKC-F810I-PHUC	DKC-F810I-PHUC
DKU Power Cord Kit (EU)	DKC-F810I-PHEC	DKC-F810I-PHEC	DKC-F810I-PHEC	DKC-F810I-PHEC
DKU Power Cord Kit (China)	DKC-F810I-PHCC	DKC-F810I-PHCC	DKC-F810I-PHCC	DKC-F810I-PHCC
FMD Chassis	DKC-F810I-FBX	DKC-F810I-FBX	DKC-F810I-FBX	DKC-F810I-FBX

Component	Model number			
	VSP G1000	VSP G1500 (upgrade from VSP G1000 to G1500)	VSP G1500	VSP F1500
FMD Chassis Bezel	DKC-F810I-BFH	DKC-F810I-BFH	DKC-F810I-BFH	DKC-F810I-BFH
FBX Power Cord Kit (USA)	DKC-F810I- PFUC	DKC-F810I- PFUC	DKC-F810I- PFUC	DKC-F810I- PFUC
FBX Power Cord Kit (EU)	DKC-F810I- PFEC	DKC-F810I- PFEC	DKC-F810I- PFEC	DKC-F810I- PFEC
FBX Power Cord Kit (China)	DKC-F810I- PFCC	DKC-F810I- PFCC	DKC-F810I- PFCC	DKC-F810I- PFCC
Additional Service Processor	DKC-F810I-SVP/ DKC-F810I- SVPC	DKC-F810I-SVP/ DKC-F810I- SVPC	DKC-F810I- SVPC	DKC-F810I- SVPC
	DKC-F810I- SVP10 <sup>1</sup> /DKC- F810I-SVP10T	DKC-F810I- SVP10 <sup>1</sup> /DKC- F810I-SVP10T	DKC-F810I- SVP10 <sup>1</sup> /DKC- F810I-SVP10T	DKC-F810I- SVP10 <sup>1</sup> /DKC- F810I-SVP10T
Additional Hub	DKC-F810I-HUB	DKC-F810I-HUB	DKC-F810I-HUB	DKC-F810I-HUB
Intercontroller Connecting Kit	DKC-F810I- MOD5	DKC-F810I- MOD5	DKC-F810I- MOD5	DKC-F810I- MOD5
Intercontroller Connecting Cable	DKC-F810I- MFC5	DKC-F810I- MFC5	DKC-F810I- MFC5	DKC-F810I- MFC5
Intercontroller Connecting Kit	DKC-F810I- MOD30	DKC-F810I- MOD30	DKC-F810I- MOD30	DKC-F810I- MOD30
Intercontroller Connecting Cable	DKC-F810I- MFC30	DKC-F810I- MFC30	DKC-F810I- MFC30	DKC-F810I- MFC30
Intercontroller Connecting Kit	DKC-F810I- MOD1J	DKC-F810I- MOD1J	DKC-F810I- MOD1J	DKC-F810I- MOD1J
Intercontroller Connecting Cable	DKC-F810I- MFC1J	DKC-F810I- MFC1J	DKC-F810I- MFC1J	DKC-F810I- MFC1J
Device Interface Cable CC1	DKC-F810I-CC1	DKC-F810I-CC1	DKC-F810I-CC1	DKC-F810I-CC1

Component	Model number			
	VSP G1000	VSP G1500 (upgrade from VSP G1000 to G1500)	VSP G1500	VSP F1500
Device Interface Cable CC2	DKC-F810I-CC2	DKC-F810I-CC2	DKC-F810I-CC2	DKC-F810I-CC2
Device Interface Cable CC4	DKC-F810I-CC4	DKC-F810I-CC4	DKC-F810I-CC4	DKC-F810I-CC4
Device Interface Cable FC5	DKC-F810I-FC5	DKC-F810I-FC5	DKC-F810I-FC5	DKC-F810I-FC5
Device Interface Cable FC30	DKC-F810I-FC30	DKC-F810I-FC30	DKC-F810I-FC30	DKC-F810I-FC30
Device Interface Cable FC1J	DKC-F810I-FC1J	DKC-F810I-FC1J	DKC-F810I-FC1J	DKC-F810I-FC1J
iSCSI 8-port 10G Host Adapter	DKC-F810I-8IS10	DKC-F810I-8IS10	DKC-F810I-8IS10	DKC-F810I-8IS10
Fibre Channel 16-port 8G Host Adapter	DKC-F810I-16FC8	DKC-F810I-16FC8	DKC-F810I-16FC8	DKC-F810I-16FC8
Fibre Channel 8-port 16G Host Adapter	DKC-F810I-8FC16	DKC-F810I-8FC16	DKC-F810I-8FC16	DKC-F810I-8FC16
Fibre Channel 16-port 16G Host Adapter	DKC-F810I-16FC16	DKC-F810I-16FC16	DKC-F810I-16FC16	DKC-F810I-16FC16
Mainframe Fibre 16-port 8G Host Adapter for Shortwave	DKC-F810I-16MS8	DKC-F810I-16MS8	DKC-F810I-16MS8	DKC-F810I-16MS8
Mainframe Fibre 16-port 8G Host	DKC-F810I-16ML8	DKC-F810I-16ML8	DKC-F810I-16ML8	DKC-F810I-16ML8

Component	Model number			
	VSP G1000	VSP G1500 (upgrade from VSP G1000 to G1500)	VSP G1500	VSP F1500
Adapter for Longwave				
Mainframe Fibre 16-port 16G Host Adapter for Shortwave	DKC-F810I-16MS16	DKC-F810I-16MS16	DKC-F810I-16MS16	DKC-F810I-16MS16
Mainframe Fibre 16-port 16G Host Adapter for Longwave	DKC-F810I-16ML16	DKC-F810I-16ML16	DKC-F810I-16ML16	DKC-F810I-16ML16
FCOE 16-port Host Adapter	DKC-F810I-16FE10	DKC-F810I-16FE10	DKC-F810I-16FE10	DKC-F810I-16FE10
Additional Cache Path Control Adapter	DKC-F810I-CPEX	DKC-F810I-CPEX	DKC-F810I-CPEX	DKC-F810I-CPEX
Cache Memory (16 GB)	DKC-F810I-CM16G	DKC-F810I-CM16G	DKC-F810I-CM16G	DKC-F810I-CM16G
Cache Memory (32 GB)	DKC-F810I-CM32G	DKC-F810I-CM32G	DKC-F810I-CM32G	DKC-F810I-CM32G
Cache Backup Module Kit for Small Memory	DKC-F810I-BKMS	DKC-F810I-BKMS	DKC-F810I-BKMS	DKC-F810I-BKMS
Cache Backup Module Kit for Large Memory	DKC-F810I-BKML	DKC-F810I-BKML	DKC-F810I-BKML	DKC-F810I-BKML
Cache Flash Memory (128 GB)	DKC-F810I-BMM128	DKC-F810I-BMM128	DKC-F810I-BMM128	DKC-F810I-BMM128
Cache Flash Memory (256 GB)	DKC-F810I-BMM256	DKC-F810I-BMM256	DKC-F810I-BMM256	DKC-F810I-BMM256

Component	Model number			
	VSP G1000	VSP G1500 (upgrade from VSP G1000 to G1500)	VSP G1500	VSP F1500
Cache Flash Memory (256 GB)	DKC-F810I- BMZ256	DKC-F810I- BMZ256	DKC-F810I- BMZ256	DKC-F810I- BMZ256
Disk Adapter	DKC-F810I-SCA	DKC-F810I-SCA	DKC-F810I-SCA	DKC-F810I-SCA
Encryption Disk Adapter	DKC-F810I- ESCA	DKC-F810I- ESCA	DKC-F810I- ESCA	DKC-F810I- ESCA
FIPS140-2 Level 2 Upgrade Toolkit	DKC-F810I- FIPS2	DKC-F810I- FIPS2	DKC-F810I- FIPS2	DKC-F810I- FIPS2
Additional Processor Blades	DKC-F810I-MP	N/A	N/A	N/A
MP2 Upgrade Kit	N/A	DKC-F810I- MP2UGH	N/A	N/A
Additional Processor Blades 2	N/A	DKC-F810I-MP2	DKC-F810I-MP2	DKC-F810I-MP2
<b>Hard disk drives</b>				
300-GB SFF disk drive 15k	DKC- F810I-300KCM	DKC- F810I-300KCM	DKC- F810I-300KCMC	N/A
	DKC- F810I-300KCMC	DKC- F810I-300KCMC		
600-GB SFF disk drive 15k	DKC- F810I-600KGM	DKC- F810I-600KGM	DKC- F810I-600KGM	N/A
600-GB SFF disk drive 10k	DKC- F810I-600JCM	DKC- F810I-600JCM	DKC- F810I-600JCMC	N/A
	DKC- F810I-600JCMC	DKC- F810I-600JCMC		
600-GB LFF disk drive 10k	DKC- F810I-600J5M	DKC- F810I-600J5M	DKC- F810I-600J5MC	N/A
	DKC- F810I-600J5MC	DKC- F810I-600J5MC		

Component	Model number			
	VSP G1000	VSP G1500 (upgrade from VSP G1000 to G1500)	VSP G1500	VSP F1500
900-GB SFF disk drive 10k	DKC- F810I-900JCM	DKC- F810I-900JCM	DKC- F810I-900JCMC	N/A
	DKC- F810I-900JCMC	DKC- F810I-900JCMC		
1.2-TB SFF disk drive 10k	DKC- F810I-1R2JCM	DKC- F810I-1R2JCM	DKC- F810I-1R2JCMC	N/A
	DKC- F810I-1R2JCMC	DKC- F810I-1R2JCMC		
1.8-TB SFF disk drive 10k	DKC- F810I-1R8JGM	DKC- F810I-1R8JGM	DKC- F810I-1R8JGM	N/A
2.4-TB SFF disk drive 10K	N/A	DKC- F810I-2R4JGM	DKC- F810I-2R4JGM	N/A
4-TB LFF disk drive 7.2k	DKC- F810I-4R0H3M	DKC- F810I-4R0H3M	DKC- F810I-4R0H3M C	N/A
	DKC- F810I-4R0H3M C	DKC- F810I-4R0H3M C		
6-TB LFF disk drive 7.2k	DKC- F810I-6R0H9M	DKC- F810I-6R0H9M	DKC- F810I-6R0H9M	N/A
<b>Solid-state drives</b>				
400-GB MLC SFF SSD	DKC- F810I-400MCM	DKC- F810I-400MCM	DKC- F810I-400MCM	N/A
400-GB MLC LFF SSD	DKC- F810I-400M5M	DKC- F810I-400M5M	DKC- F810I-400M5M	N/A
800-GB MLC SFF SSD	DKC- F810I-800MCM	DKC- F810I-800MCM	DKC- F810I-800MCM	N/A
960-GB MLC SFF SSD	DKC- F810I-960MGM	DKC- F810I-960MGM	DKC- F810I-960MGM	DKC- F810I-960MGM
1.9-TB MLC SFF SSD	DKC- F810I-1R9MGM	DKC- F810I-1R9MGM	DKC- F810I-1R9MGM	DKC- F810I-1R9MGM
3.8-TB MLC SFF SSD	DKC- F810I-3R8MGM	DKC- F810I-3R8MGM	DKC- F810I-3R8MGM	DKC- F810I-3R8MGM



Component	Model number			
	VSP G1000	VSP G1500 (upgrade from VSP G1000 to G1500)	VSP G1500	VSP F1500
7.6-TB TLC SFF SSD	N/A	DKC-F810I-7R6MGM	DKC-F810I-7R6MGM	DKC-F810I-7R6MGM
15-TB TLC SFF SSD	N/A	DKC-F810I-15RMGM	DKC-F810I-15RMGM	DKC-F810I-15RMGM
<b>Flash module drives (FMD)</b>				
1.75-TB FMD	DKC-F810I-1R6FM	DKC-F810I-1R6FM	N/A	N/A
	DKC-F810I-1R6FN	DKC-F810I-1R6FN	DKC-F810I-1R6FN	DKC-F810I-1R6FN
3.5-TB FMD	DKC-F810I-3R2FM	DKC-F810I-3R2FM	N/A	N/A
	DKC-F810I-3R2FN	DKC-F810I-3R2FN	DKC-F810I-3R2FN	DKC-F810I-3R2FN
7-TB FMD HD	DKC-F810I-6R4FN	DKC-F810I-6R4FN	DKC-F810I-6R4FN	DKC-F810I-6R4FN
	DKC-F810I-7R0FP	DKC-F810I-7R0FP	DKC-F810I-7R0FP	DKC-F810I-7R0FP
14-TB FMD HD	DKC-F810I-14RFP	DKC-F810I-14RFP	DKC-F810I-14RFP	DKC-F810I-14RFP
7-TB FMD-HDE	N/A	DKC-F810I-7R0FPE <sup>2</sup>	DKC-F810I-7R0FPE <sup>2</sup>	DKC-F810I-7R0FPE <sup>2</sup>
14-TB FMD-HDE	N/A	DKC-F810I-14RFPE <sup>2</sup>	DKC-F810I-14RFPE <sup>2</sup>	DKC-F810I-14RFPE <sup>2</sup>
<b>Notes:</b>				
<sup>1</sup> Microsoft Windows 10 IoT Enterprise is installed.				
<sup>2</sup> Supports embedded FMD accelerated compression capabilities with data-at-rest encryption.				

## System controller chassis

The following figures show the front and rear views of a system controller chassis, and the following tables list the description of the components.

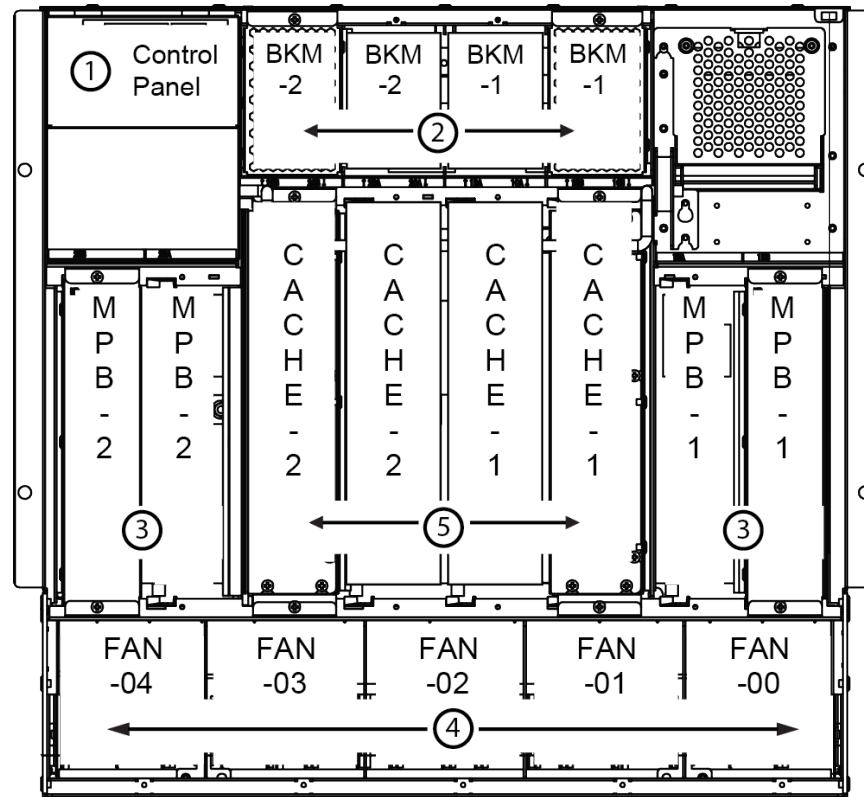

Figure 1 Controller, front view

Table 5 Controller components, front view

Item	Name	Min	Max	Description
1	Control Panel	1	1	See <a href="#">Power control panel (on page 122)</a> .
2	Cache Backup Module (BKM)	2	4	Backup memory modules are installed in pairs and referred to as a backup memory kit. Each module contains two batteries and either a 128 GB SSD (small kit) or a 256 GB SSD (large kit).  If the power fails, the cache is protected from data loss by the backup batteries and the cache flash memory (SSD). The batteries keep the cache active up to 32 minutes while the data is copied to the SSD.

Item	Name	Min	Max	Description
3	<ul style="list-style-type: none"> <li>▪ Virtual storage director (2.1 GHz)</li> <li>▪ Virtual storage director (2.3 GHz)</li> </ul>	2 (1 pair)	8 (4 pairs)	<p>A VSD can contain either an Intel Xeon 2.1 GHz or 2.3 GHz 8-core microprocessor.</p> <p>The VSDs are independent of the front-end directors and back-end directors, and can be shared across them.</p> <p>The VSDs must be installed in pairs and the VSDs control the front-end directors, back-end directors, PCI Express interface, local memory, and communication to the SVP.</p>
4	Cooling fan (intake)	5	5	The five intake fans on the front of the controller pull air into the controller and distribute it across the controller components.
5	Cache Path Control Adapter (CPA)	1	4	The CPA uses the built-in switch to connect the VSDs to the front-end directors, back-end directors, and the cache backup memory. It distributes data (data routing function) and sends hot-line signals to the VSD. The shared memory is located on the first CPA cache board in each cluster in the primary controller.

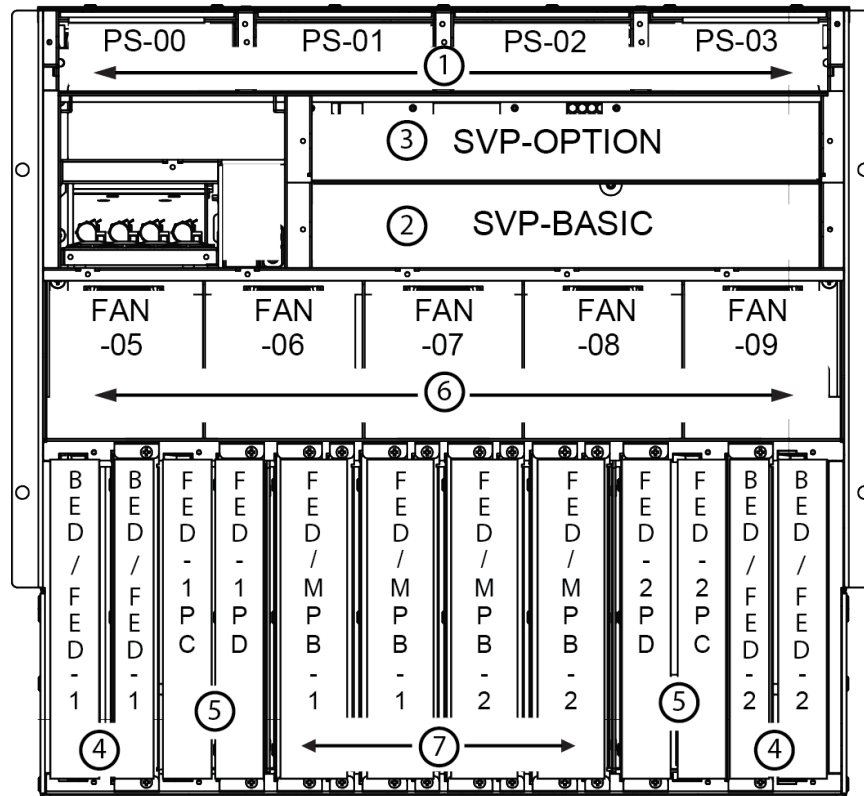

Figure 2 Controller, rear view

**Table 6 Controller components, rear view**

Item	Name	Min	Max	Description
1	Power supply	2	4	200-240 VAC input. Provides power to the controller chassis in a redundant configuration. Each power supply contains two cooling fans to ensure constant cooling if one fan fails.
2	Service processor (SVP)	1	2	A custom PC monitoring and controlling the storage system. It contains the Device Manager - Storage Navigator software, which configures and monitors the system. Connecting the SVP to a service center enables the storage system to be remotely monitored and maintained by the support team.
3	Service processor (SVP) or Hub	0	1	This space can be empty or can contain either a second SVP or a hub. If a second SVP is installed, the primary SVP is the active SVP, and the secondary SVP is the hot idle SVP with active Windows. A hub facilitates the transfer of information from the VSD pairs to the primary SVP.
4	Back-end director or (optional) front-end director	0 if diskless 2 with drives	4	Connects the HDDs, SSDs, and FMDs. It controls the data transfer between the drives and the cache.  VSP G1000, VSP G1500, and VSP F1500 support two types of back-end directors: <ul style="list-style-type: none"> <li>Standard back-end director</li> <li>Encrypting back-end director<sup>1</sup></li> </ul> Important: Each back-end director and front-end director consists of a set of two of blades. See <a href="#">Flexible front-end director installation (on page 42)</a> for details.
5	Front-end director (host I/O module)	1	2 to 5 with drives 6 if diskless system	A front-end director (FED) provide ports that support connectivity to the open and mainframe systems belonging to the customer. In addition, some of the FEDs support virtualization of externally attached storage, remote replication between VSP G1000, VSP G1500, and VSP F1500 and other storage systems, including communication between two Hitachi storage systems in a global active device cluster. See <a href="#">Front-end directors (on page 37)</a> for details.
6	Cooling fan (exhaust)	5	5	The exhaust fans on the rear of the controller pull hot air away from the components and push it out the back of the rack.

Item	Name	Min	Max	Description
7	FED or VSD slot	0	4	The slots on the controller support both front-end directors and VSDs. Both FEDs and VSDs must be installed in pairs.
<b>Note:</b> 1. Achieved FIPS 140-2 Level 1 certification.				

## Front-end directors

A front-end director (FED) is a pair of blades installed in the controller.

The FED connects the storage system to the host servers, processes channel commands from hosts, manages host access to the cache, and controls the transfer of data between the hosts and the controller cache.

The following FEDs are available:

- iSCSI
- Fibre Channel
- FICON (shortwave and longwave)
- Fibre Channel over Ethernet (FCoE)

The Fibre Channel FED can be configured with either shortwave or longwave host connectors. The FICON is configured with either longwave or shortwave connectors that match the wavelength of the mainframe ports.

The following figure shows the port LEDs of a FED, and the following table lists the description of the port LEDs.

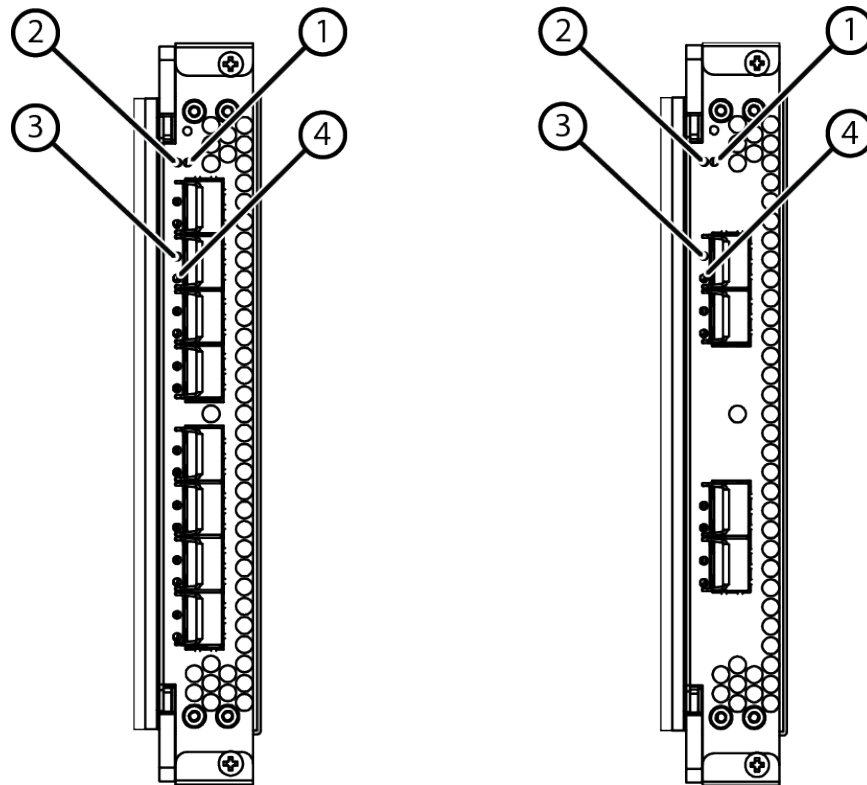

**Figure 3 front-end director blade, Fibre Channel and iSCSI**

Item	Name	Color	Description
1	Blade Status	Dark (off) Red (on)	OFF: Power is not supplied to the system. The system is not operational. ON: Board failure. The blade can be replaced while the system is running.
2	Power supply Status	Dark (off) Amber (on)	OFF: Power is not supplied to the system or, if power is supplied to the system, power supply in this blade is operational. ON: Power supply failure, abnormal voltage in power supply.
3	Port Status (FC/ iSCSI)	Dark (off) Green (on)	OFF: If system power is off, the port is not ready. OFF: If system power is on, the port is ready. ON: Link is active.
4	Link Activity (FC/ iSCSI)	Dark (off) Green (on)	OFF: No link activity, for three possible reasons: power is off, initialization is not completed, and if system is operational, the port is not being accessed. ON (steady): Link is available and initialization is complete, but connection to the host has not been established.

Item	Name	Color	Description
			Blinking: When the port is being accessed and data is being transferred between the host and the cache.
3	Port Status (FICON)	Dark (off) Green (on)	OFF: If system power is off, the port is not ready. ON: Link is available and initialization is complete, but connection to the host has not been established. ON: Link is active.
4	Link Activity (FICON)	Dark (off) Amber (on)	OFF: No link activity because either power is off, initialization is not complete, or, if the system is operational, the port is not being accessed. ON (fast blink): When the port is being accessed and data is being transferred between the host and the cache.

## Supported connectors and protocols

### Ports

A variety of FED options are available for installation in the controller chassis. The maximum number of ports configurable in a two controller system by FED type are as follows:

- 96 iSCSI ports (10 Gbps, 8-port)
- 192 Fibre Channel ports (16 Gbps, 16-port)
- 192 Fibre Channel ports (8 Gbps, 16-port)
- 96 Fibre Channel ports (16 Gbps, 8-port)
- 176 FICON ports (16 Gbps, 16-port) available in longwave and shortwave versions
- 176 FICON ports (8 Gbps, 16-port) available in longwave and shortwave versions
- 192 FCoE ports (10 Gbps, 16-port)



**Note:** A storage system can be configured with a mixture of FED pairs thus providing a variety of port types.

See [Site preparation \(on page 78\)](#) for information about port configurations.

### Fibre Channel host connectors

The Fibre Channel FED uses a host connector which is an LC-type optical transceiver that converts electrical signals from the FED to light pulses that are supported by the fiber optic cables. Host connectors are either shortwave or longwave. Fibre Channel FEDs are configured with shortwave host connectors by default. Longwave host connectors are available and can be substituted as needed.

The following figure shows the SFP transceiver of a host connector.

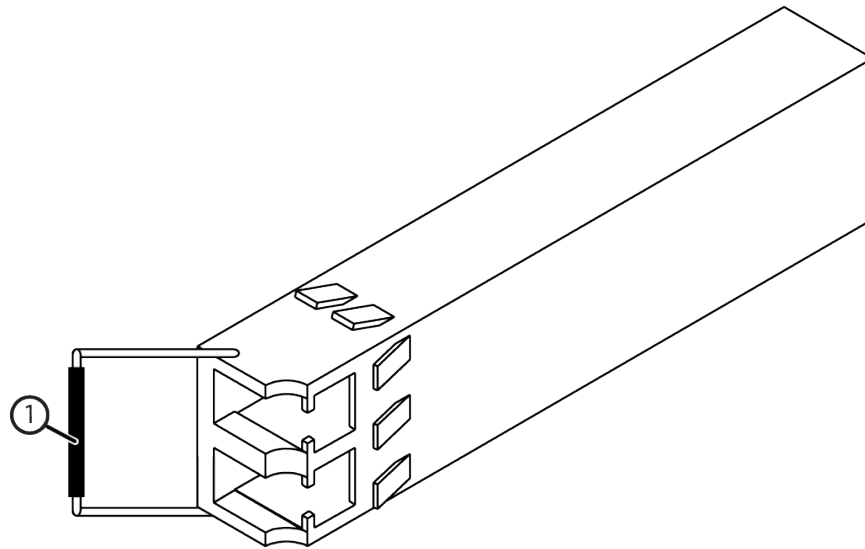

Item	Description
1 - Host connector lock lever	Black lever = shortwave Blue lever = longwave

### Protocols

Fibre Channel, iSCSI and Fibre Channel over Ethernet (FCoE) FEDs support open system hosts while FICON FEDs support mainframe systems.

The following tables lists the supported FEDs and protocols.

FED	System	Ports	Mode	Description
8-port, 10-Gbps iSCSI	Open	8 (4 per blade)	Target and Initiator <sup>1</sup>	Contains two 4-port front-end modules. Each port contains a short wavelength (multi-mode) host connector.
16-port, 16-Gbps Fibre Channel, shortwave and longwave adapter	Open	16 (8 per blade)	Target and Initiator <sup>1</sup>	Contains two 8-port front-end modules. Each port contains an LC-type short wavelength, multimode host connector. These are installed by default.



FED	System	Ports	Mode	Description
				A long wavelength host connector (-1PL8) for single mode can be used instead of the short wavelength host connector.
16-port, 8-Gbps Fibre Channel, shortwave and longwave adapter	Open	16 (8 per blade)	Target and Initiator <sup>1</sup>	<p>Contains two 8-port front-end modules. Each port contains an LC-type short wavelength, multi-mode host connector. These are installed by default.</p> <p>A long wavelength host connector (-1PL8) for single mode may be used instead of the short wavelength host connector.</p>
8-port, 16-Gbps Fibre Channel, shortwave and longwave adapter	Open	8 (4 per blade)	Target and Initiator <sup>1</sup>	<p>Contains two 4-port front-end modules. Each port contains an LC-type short wavelength, multi-mode host connector. These are installed by default.</p> <p>A long wavelength host connector (-1PL16) for single mode may be used instead of the short wavelength host connector.</p>
16-port, 8-Gbps FICON shortwave adapter	Mainframe	16 (8 per blade)	Target	Contains two 8-port front-end modules. Each port contains a short wavelength (multi-mode) host connector.
16-port, 8-Gbps FICON longwave adapter	Mainframe	16 (8 per blade)	Target	Contains two 8-port front-end modules. Each port contains an LC-type long wavelength (multi-mode) host connector.

FED	System	Ports	Mode	Description
16-port, 16-Gbps FICON shortwave adapter	Mainframe	16 (8 per blade)	Target	Contains two 8-port front-end modules. Each port contains a short wavelength (multi-mode) host connector.
16-port, 16-Gbps FICON longwave adapter	Mainframe	16 (8 per blade)	Target	Contains two 8-port front-end modules. Each port contains an LC-type long wavelength (multi-mode) host connector.
16-port, 10-Gbps Fibre Channel over Ethernet (FCoE)	Open	16 (8 per blade)	Target and Initiator <sup>1</sup>	Contains two 8-port front-end modules. Each port contains a short wavelength (multi-mode) host connector.
<b>Notes:</b>				
1. Supports remote replication, including TrueCopy <sup>®</sup> , global-active device, Hitachi Universal Replicator, and Hitachi Universal Volume Manager.				

## Flexible front-end director installation

The maximum number of FEDs that can be installed in the controller depends on the number of VSD pairs and FEDs (BED) that are also installed.

As shown in the following figure, the controller is built with 12 I/O slots, eight of which are dual-purpose. This provides a wide range of configuration flexibility.



**Note:** Each FED and BED consists of a set of two blades, as indicated by the numbers in the figure. A VSD pair, however, uses a single slot, but is sold and installed in pairs.

The following list describes the purpose of the slots.

- Eight of the 12 I/O slots support different types of devices.
- Slots 1C/2C and 1D/2D are reserved for the first two FEDs.
- Slots 1E/2E and 1F/2F support the installation of either FEDs or VSDs.
- Slots 1A/2A and 1B/2B support the installation of either BEDs or VSDs.

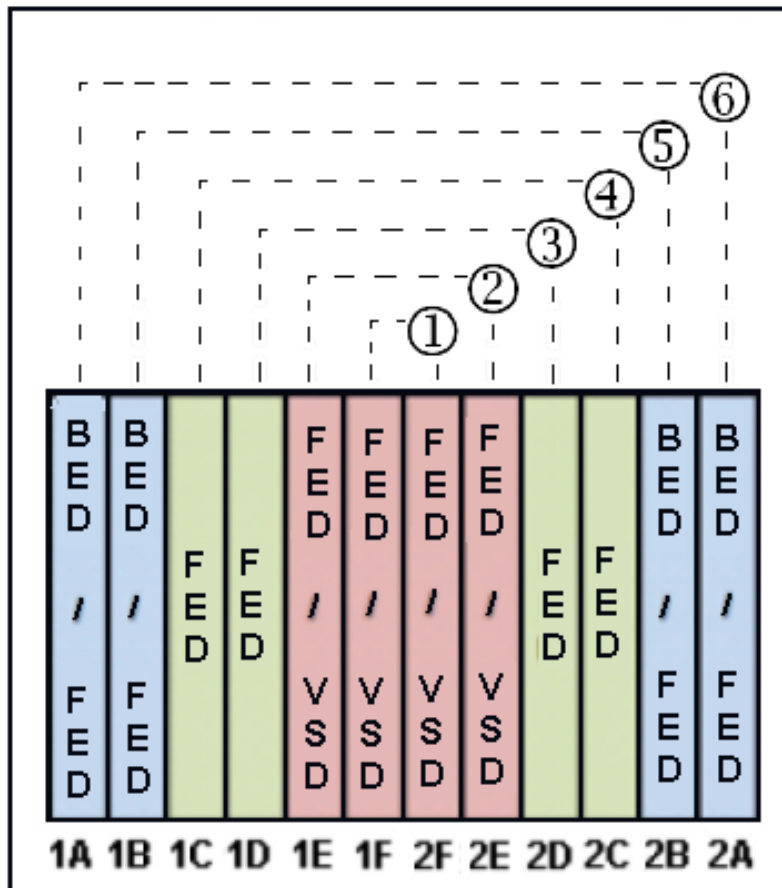

The following table shows the order of FED installation. If the storage system includes internal drives, the controller requires a minimum of a single pair of BEDs and can be configured to support up to two BED pairs. A storage system that does not include any internal drives is referred to as a *diskless* configuration. The term *standard* describes a controller configured with a single BED, while *high performance* describes a controller configured with two BED pairs.

Table 7 VSP G1000 FED installation order

Installation slot location						
Installation order (see the previous figure)	Diskless model		Standard model		High-performance model	
	DKC810I-CBXA/CBXAC	DKC-F810I-CBXB	DKC810I-CBXA/CBXAC	DKC-F810I-CBXB	DKC810I-CBXA/CBXAC	DKC-F810I-CBXB
1	1PC/2PC (CHA0)	1PJ/2PJ (CHA6)	1PC/2PC (CHA0)	1PJ/2PJ (CHA6)	1PC/2PC (CHA0)	1PJ/2PJ (CHA6)
2	1PD/2PD (CHA1)	1PK/2PK (CHA7)	1PD/2PD (CHA1)	1PK/2PK (CHA7)	1PD/2PD (CHA1)	1PK/2PK (CHA7)
3	1PE/2PE (CHA2/ MPB3)	1PL/2PL (CHA8/ MPB7)	1PE/2PE (CHA2/ MPB3)	1PL/2PL (CHA8/ MPB7)	1PE/2PE (CHA2/ MPB3)	1PL/2PL (CHA8/ MPB7)
4	1PF/2PF (CHA3/ MPB2)	1PM/2PM (CHA9/ MPB6)	1PF/2PF (CHA3/ MPB2)	1PM/2PM (CHA9/ MPB6)	1PF/2PF (CHA3/ MPB2)	1PM/2PM (CHA9/ MPB6)
5	1PB/2PB (DKA1/ CHA4)	1PH/2PH (DKA3/ CHA10)	1PB/2PB (DKA1/ CHA4)	1PH/2PH (DKA3/ CHA10)	—	—
6	1PA/2PA (DKA0/ CHA5)	1PG/2PG (DKA2/ CHA11)	—	1PG/2PG (DKA2/ CHA11)	—	—

**Table 8 VSP G1500 and VSP F1500 FED installation order**

Installation slot location						
Installation order (see the previous figure)	Diskless model		Standard model		High-performance model	
	DKC810I-CBXE	DKC810I-CBXF	DKC810I-CBXE	DKC810I-CBXF	DKC810I-CBXE	DKC810I-CBXF
1	1PC/2PC (CHA0)	1PJ/2PJ (CHA6)	1PC/2PC (CHA0)	1PJ/2PJ (CHA6)	1PC/2PC (CHA0)	1PJ/2PJ (CHA6)
2	1PD/2PD (CHA1)	1PK/2PK (CHA7)	1PD/2PD (CHA1)	1PK/2PK (CHA7)	1PD/2PD (CHA1)	1PK/2PK (CHA7)
3	1PE/2PE (CHA2/ MPB3)	1PL/2PL (CHA8/ MPB7)	1PE/2PE (CHA2/ MPB3)	1PL/2PL (CHA8/ MPB7)	1PE/2PE (CHA2/ MPB3)	1PL/2PL (CHA8/ MPB7)
4	1PF/2PF (CHA3/ MPB2)	1PM/2PM (CHA9/ MPB6)	1PF/2PF (CHA3/ MPB2)	1PM/2PM (CHA9/ MPB6)	1PF/2PF (CHA3/ MPB2)	1PM/2PM (CHA9/ MPB6)
5	1PB/2PB (DKA1/ CHA4)	1PH/2PH (DKA3/ CHA10)	1PB/2PB (DKA1/ CHA4)	1PH/2PH (DKA3/ CHA10)	—	—
6	1PA/2PA (DKA0/ CHA5)	1PG/2PG (DKA2/ CHA11)	—	1PG/2PG (DKA2/ CHA11)	—	—

## Supported speeds and cable lengths

The Fibre Channel FEDs can be configured with either shortwave or longwave host connectors that match the cables connecting it to the host systems.

The following table lists the Fibre Channel cable length requirements for the front-end directors for the storage system.

**Table 9 Maximum cable length (shortwave)**

Data transfer rate	OM2 cable (50/125 $\mu\text{m}$ multi-mode fiber)	OM3 cable (50/125 $\mu\text{m}$ laser optimized, multimode fiber)	OM4 cable (50/125 $\mu\text{m}$ laser optimized, multimode fiber)
MBps	feet / meters	feet / meters	feet / meters
200	984.3 / 300	1640.4 / 500	N/A
400	492.1 / 150	1246.7 / 380	1312.4 / 400

Data transfer rate	OM2 cable (50/125 $\mu\text{m}$ multi-mode fiber)	OM3 cable (50/125 $\mu\text{m}$ laser optimized, multimode fiber)	OM4 cable (50/125 $\mu\text{m}$ laser optimized, multimode fiber)
MBps	feet / meters	feet / meters	feet / meters
800	164 / 50	492.1 / 150	623.4 / 190
1600	118 / 35	328 / 100	410.1 / 125

Table 10 Maximum cable length (longwave)

Data transfer rate ( MBps)	OM3 cable length (km)
200, 400, 800, 1600	10

## Back-end director

A back-end director (BED) is a pair of blades installed into the controller chassis and it controls the data transfer between the cache memory and internal drives of the storage system.

Hitachi offers the following BEDs:

- Standard back-end director
- Encrypting back-end director

The *standard* back-end director blades are each equipped with four 6-Gbps SAS ports and do not support encryption.

The *encrypting* back-end director (EBED) blades each provide four 6-Gbps SAS ports. When writing data to the internal drives of the system, the EBED encrypts the data. The encrypted data-at-rest is unencrypted by the EBED as it is read from the drive. The EBED is certified as FIPS 140-2 Level 2 compliant to meet the strict security standards of customers managing storage systems. A Hitachi Encryption License Key must be installed during installation in order to enable the encryption functionality of the EBED and an additional license key known as FIPS 140-2 Level 2 License Key must be installed for operating in compliance with the FIPS 140-2 Level 2 specification. For more information about the encrypting back-end directors and implementing a storage system with FIPS 140-2 Level 2 compliance, contact a Hitachi Vantara representative.

For more information about FIPS 140-2 criteria and certificate for VSP G1x00, see the following websites:

- FIPS 140-2: <http://csrc.nist.gov/groups/STM/cmvp/standards.html>
- FIPS 140-2 Level 2 certificate #2727 for the VSP G1x00: <http://csrc.nist.gov/groups/STM/cmvp/documents/140-1/1401val2016.htm#2727>

The hardware components used in the standard back-end director blades are different from the encrypting back-end director blades. A BED pair may not consist of one standard and one encrypting blade.

## Flexible back-end director installation

Use the following guideline when installing *standard* and *encrypting* back-end directors (BEDs).

A maximum of two BEDs can be installed in both the primary controller chassis and secondary controller chassis for a total of four BEDs per system. Only one type of BEDs can be installed into a system. The *standard* and *encrypting* BEDs cannot be mixed in the storage system. The maximum number of BED pairs that can be installed into a controller chassis will depend on the number of FEDs that will also be installed into the controller chassis.

A system without internal drives (also known as a *diskless* configuration) does not require the installation BEDs. However, the system must include one or more FED pairs to provide ports to connect to externally attached storage as well as to host systems.

For more information about configuration rules for FEDs and BEDs, see [Flexible front-end director installation \(on page 42\)](#).

## Drive chassis

The VSP G1x00 support three different drive chassis. The VSP F1500 only supports the FMD chassis. All components in the drive chassis are configured with redundant pairs to prevent system failure. While the storage system is in operation, all components in the drive chassis can be added or replaced. For detailed information about the drives in each chassis, see [Storage system specifications \(on page 134\)](#).

Drive chassis	Description	Drive trays / Drives per tray	Maximum number of chassis / drives per system	
			Single controller (3 racks)	Dual controller (6 racks)
SFF	A 16U group of eight 2U drive trays. Each holds up to 24 vertically positioned 2.5-inch HDD and SSD drives, for a total of 192 SFF drives per chassis. See <a href="#">Figure 28 SAS connection diagram of Rack-00 (SFF/LFF standard model) (on page 112)</a> .	Eight 2U trays, up to 24 drives each	6 / 1,152 hard drives Up to 192 SSDs <sup>1</sup> Up to 1,152 SSDs <sup>2</sup>	12 / 2,304 drives Up to 384 SSDs <sup>1</sup> Up to 2,304 SSDs <sup>2</sup>

Drive chassis	Description	Drive trays / Drives per tray	Maximum number of chassis / drives per system	
			Single controller (3 racks)	Dual controller (6 racks)
LFF	A 16U group of eight 2U drive trays. Each holds up to 12 horizontally positioned 3.5-inch drives, for a total of 96 LFF drives per chassis. See <a href="#">Figure 28 SAS connection diagram of Rack-00 (SFF/LFF standard model) (on page 112)</a> .	Eight 2U trays, up to 12 drives each	6 / 576 hard drives Up to 192 SSDs <sup>1</sup> Up to 1,152 SSDs <sup>2</sup>	12 / 1,152 Up to 384 SSDs <sup>1</sup> Up to 2,304 SSDs <sup>2</sup>
FMD	An 8U group of four 2U drive trays. Each holds up to 12 horizontally positioned drives, for a total of 48 FMDs per chassis. See <a href="#">Figure 30 SAS connection diagram of Rack-00 (FBX standard model) (on page 114)</a> .	Four 2U trays, up to 12 drives each	6 / 288	12 / 576
<sup>1</sup> Maximum number in a standard-performance configuration. <sup>2</sup> Maximum number in a high-performance configuration.				

The following illustrations show the front and rear panels of the three types of 2U drive trays, and the following tables describe the connectors and LEDs.

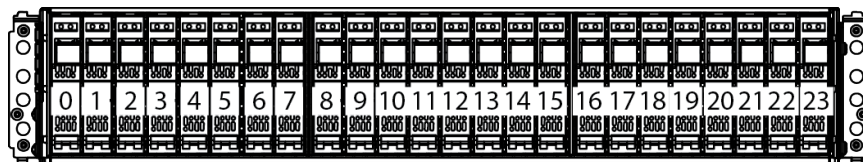



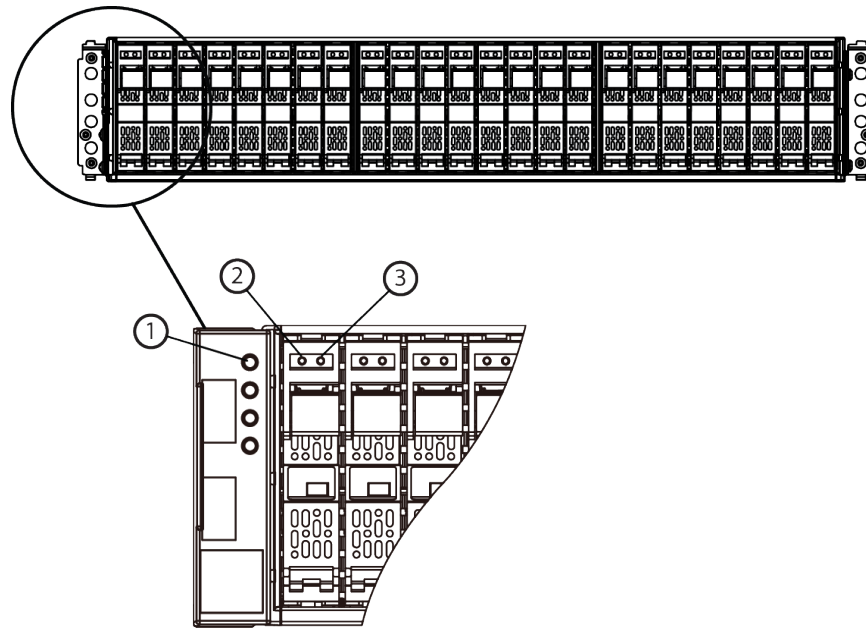

Figure 4 SFF 2U drive tray diagram and front view

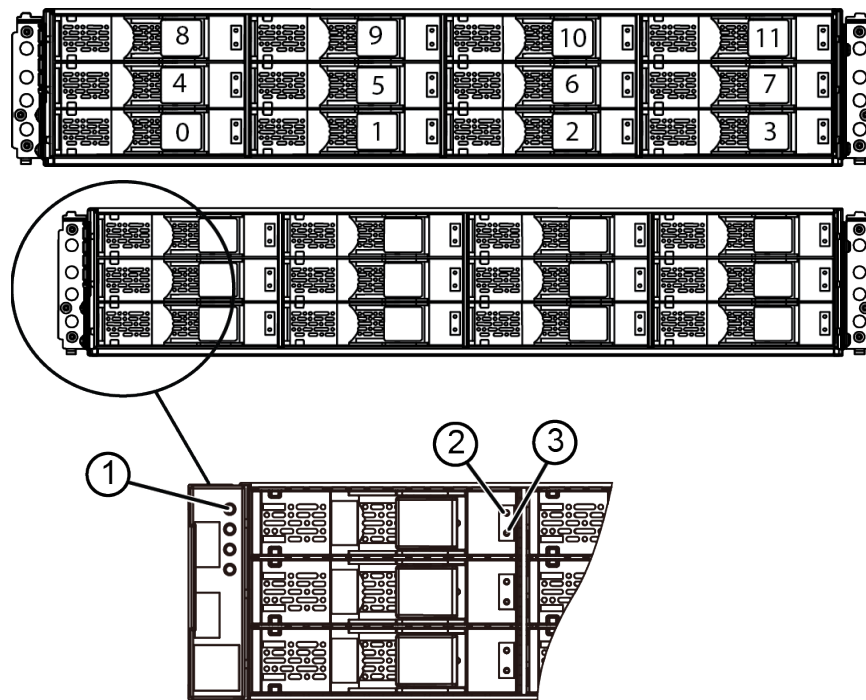

Figure 5 LFF 2U drive tray, front view

Item	Name	Color	Description
1	POWER LED	Green	OFF: Power is not supplied to the system. ON: Power is supplied to the system.

Item	Name	Color	Description
	READY LED	Green	OFF: System is not operational. ON: Normal operation. Storage system is operational. Fast blink - internal processing. Storage system is operational. Slow blink - offline download processing completed (maintenance).
	LOCATE LED	Orange	OFF: Normal operation ON: Nonfatal error. Storage system can remain operating. Contact technical support. See <a href="#">Getting help (on page 131)</a> in the preface of this manual.
2	ALM LED (alarm)	Red	OFF: Normal operation ON: Fatal error. Contact technical support. See <a href="#">Getting help (on page 131)</a> in the preface of this manual.
3	ACT LED (Active)	Green	OFF: Drive is not being accessed. Blinking: Drive is being accessed.

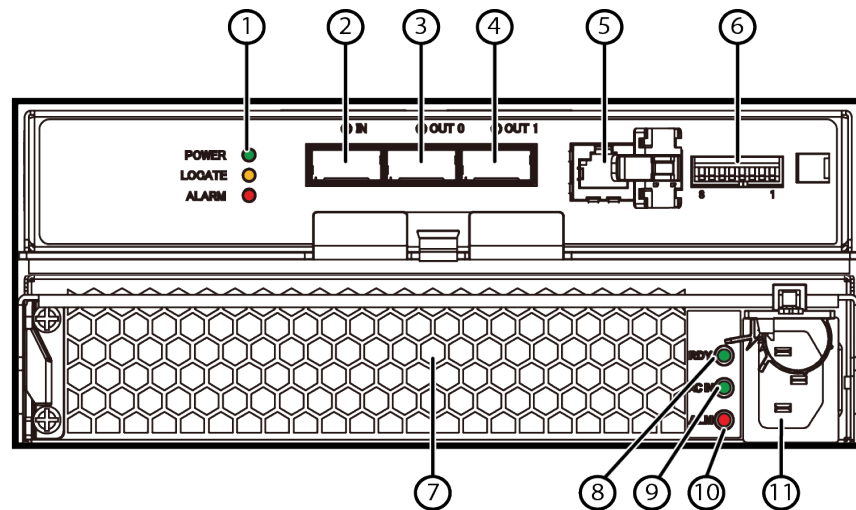

Figure 6 2U SFF and LFF drive tray, rear view

Item	Name	Color	Description
1	POWER LED	Green	OFF: No power is supplied to the system. ON: Power is supplied to the system.
	READY LED	Green	ON: Normal operation. Storage system is operational. Fast blink: Internal processing. Storage system is operational.

Item	Name	Color	Description
			Slow blink: Offline download processing completed (maintenance).
	LOCATE LED	Orange	ON: Nonfatal error. Storage system can continue operating. Contact technical support. See <i>Getting Help</i> in the preface of this manual.
2	ENC IN LED	Green	ON: Port is connected to an OUT port in the controller. This can be directly or via another drive box with daisy-chained cables.
3	ENC IN connector	-	Connects the drives to the ENC OUT port in the control chassis either directly or via another drive box with daisy-chained cables.
4	ENC OUT connector	-	Connects the drives to the ENC IN port in the control chassis either directly, or via another drive box with daisy-chained cables.
5	ENC OUT LED	Green	ON: Indicates that the port is connected to an IN port in the controller. This can be performed directly or indirectly, as previously described.
6	Console port	-	RJ-45 connector (not used)
7	Power Supply	-	Converts 200 VAC to the DC voltages used by the drives and the ENC adapters.
8	RDY (Ready) LED	Green	OFF: No power is supplied to the system or the power supply has failed. ON: The power supply is operating normally.
9	AC IN LED	Green	ON: AC input is normal.
10	ALM (Alarm) LED	Red	Power supply has failed. Contact technical support. See <i>Getting Help</i> in the preface of this manual.
11	AC Socket	-	For IEC60320-C14 plug: 200 - 240 VAC +8% - 6% 50/60 Hz

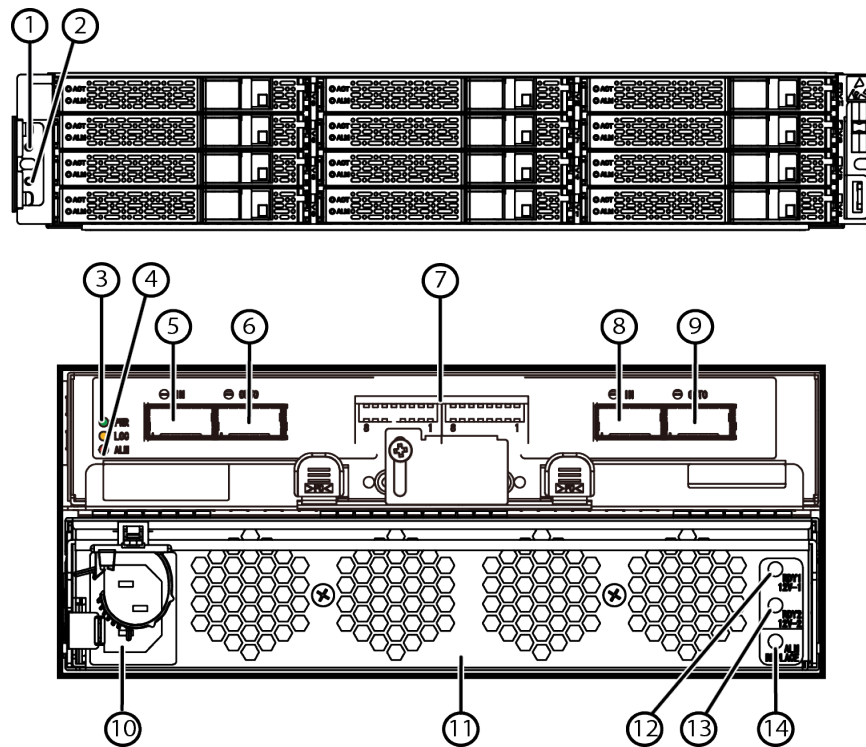

Figure 7 FMD drive tray

Item	Description
1	Flash module Active LED - Lights when the flash module is activated - Blinks at drive access.
2	Flash module Alarm LED - Lights when the flash module has an error and should be replaced.
3	SAS / ENC Module Power LED
4	SAS / ENC Module Alarm LED - Indicates fatal error condition.
5	SAS / ENC standard IN connector
6	SAS / ENC high performance IN connector
7	ENC adapter - Connects the flash modules to the BEDs in the controller through ENC cables.
8	SAS / ENC standard OUT connector
9	SAS / ENC high performance OUT connector
10	Power cord receptacle
11	Power Supply - 220 VAC input, draws approximately 265 watts.
12	Power Supply Ready 1 LED - Lights when 12 VDC power #1 is ready.

Item	Description
13	Power Supply Ready 2 LED - Lights when 12 VDC power #2 is ready.
14	Power Supply alarm LED - Lights when power supply has an error.

## Cache memory

The VSP G1000, VSP G1500, and VSP F1500 storage systems can be configured with 64 GB to 1 TB of cache memory per controller. The cache memory is installed in one or two cache path control adapters (CPA). A CPA feature consists of a pair of redundant blades that are installed and work together to provide cache and shared memory for the system. The following figure shows two CPAs (2-3, and 1-4).

Cache memory modules (DIMMs) are available in either 16 GB or 32 GB sizes. The minimum memory required per controller is 64 GB, either two 16 GB DIMMs or one 32 GB DIMM must be installed in each CPA blade. The memory modules in a system must all be the same size.

The following table shows minimum and maximum cache capacities per controller. The figures are doubled for a two-controller system.

**Table 11 Cache capacities per controller**

# of controller chassis configuration	Capacity of cache memory module	Maximum cache capacity configurable based on the number of cache path control adapter pairs included:	
		1 cache path control adapter pair (included with controller)	2 cache path control adapter pairs (one included with controller and an additional feature added)
VSP G1000, VSP G1500, and VSP F1500 including a Primary controller chassis only	16 GB	256 GB	512 GB
	32 GB	512 GB	1024 GB
VSP G1000, VSP G1500, and VSP F1500 including both a Primary and Secondary controller chassis	16 GB	512 GB	1024 GB
	32 GB	1024 GB	2048 GB
<b>Notes:</b>			

# of controller chassis configuration	Capacity of cache memory module	Maximum cache capacity configurable based on the number of cache path control adapter pairs included:	
		1 cache path control adapter pair (included with controller)	2 cache path control adapter pairs (one included with controller and an additional feature added)
<ol style="list-style-type: none"> <li>One DIMM minimum, eight DIMMs maximum per board. Two blades/boards per CPA. One or two CPAs installed per controller.</li> <li>HDS minimum cache per system is 64 GB whether configured with one or two controllers.</li> </ol>			

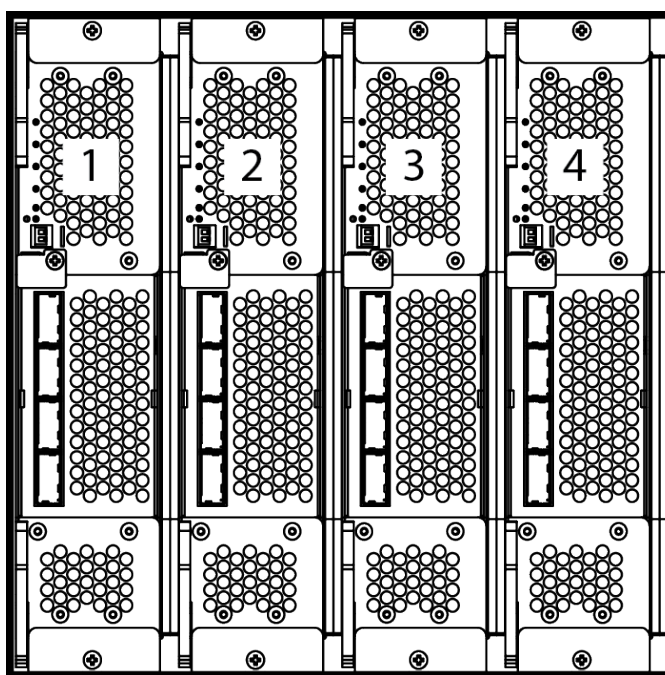

Item	Description	Item	Description
2 and 3	Main (required) cache path control adapters	1 and 4	Optional cache path control adapters
1 and 2	Cluster 1	3 and 4	Cluster 0

## Memory operation

The controller places all read and write data into the cache. The amount of fast-write data in cache is dynamically managed by the cache control algorithms to provide an optimum amount of read and write cache, depending on the workload read and write I/O characteristics.

## Data protection

The VSP G1000, VSP G1500, and VSP F1500 storage systems protect the loss of data or configuration information stored in the cache when electrical power fails. The cache is kept active for up to 32 minutes by the cache backup batteries while the system configuration and data are copied to the cache flash memory in the cache backup modules. For more information, see [Cache flash memory \(on page 60\)](#) and [Battery backup operations \(on page 128\)](#).

## Cache capacity

The recommended amount of cache to install is determined by the RAID level, the number of drives installed in the system, and whether Hitachi Dynamic Provisioning (HDP), Hitachi Dynamic Tiering (HDT), Dynamic Cache Residency (DCR), and Universal Volume Manager (UVM) are applied. The recommended data cache capacity per Cache Logical Partition (CLPR) = (CLPR capacity) - (DCR Extent setting capacity per CLPR). When CLPR is not applied to DP/DT/DCR, install the recommended data cache capacity shown in the following table.

To configure a system for maximum performance, contact your authorized Hitachi Vantara representative. See *Getting Help* in the preface of this manual.

**Table 12 Recommended data cache capacity when DP, DT, DCR, and UVM are not being used**

Total logical capacity of external volumes + internal volumes per CLPR	Recommended data cache capacity per CLPR
Less than 2,900 GB	15 GB or more
Less than 2,900 GB	15 GB or more
2,900 GB or more	16 GB or more
11,500 GB or more	22 GB or more
14,400 GB or more	24 GB or more
100,000 GB or more	30 GB or more
128,000 GB or more	32 GB or more
182,000 GB or more	40 GB or more
218,000 GB or more	48 GB or more

Total logical capacity of external volumes + internal volumes per CLPR	Recommended data cache capacity per CLPR
254,000 GB or more	56 GB or more
290,000 GB or more	64 GB or more
326,000 GB or more	72 GB or more

## Shared memory

Shared memory holds storage system configuration information and stored in the cache. The capacity of the shared memory + the capacity of the cache memory = the total capacity of the cache memory needed by the storage system.

The capacity overheads associated with the capacity saving function (data deduction) include capacity consumed by metadata and capacity consumed by garbage (invalid) data. For more information, see the *Provisioning Guide for Open Systems*. The recommendation is to use 0.2% of active data size as cache size (200 GB of cache for every 100 TB of pool capacity to be reduced).

The following table shows the shared memory capacity needed depending on the kind of software applications installed in the system.

Number of control unit	Determining factor of SM capacity										iSC SI	DC	SM capacity
	Software <sup>1</sup>						64KL DEV extension	HDP/HDT/AF extension					
	SI/VM/NDM	HDP/TI/FC	TPF	TC/UR/GAD	HDT/AF			1	2	3			
1-64 (16k LDEV)	Apply	Apply	—	—	—	—	—	—	—	—	—	—	16 GB
1-64 (16k LDEV)	Apply	Apply	—	Apply	—	—	—	—	—	—	—	—	24 GB
1-64 (16k LDEV)	Apply	Apply	—	—	Apply	—	—	—	—	—	—	—	24 GB
1-64 (16k LDEV)	Apply	Apply	—	—	—	—	Apply	—	—	—	—	—	24 GB



Number of control unit	Determining factor of SM capacity										iSCSI	DC	SM capacity
	Software <sup>1</sup>					64KL DEV extension	HDP/HDT/AF extension						
	SI/VM/NDM	HDP/TI/FC	TPF	TC/UR/GAD	HDT/AF		1	2	3				
1-255 (64k LDEV)	Apply	Apply	Apply	—	—	Apply	—	—	—	Apply	Apply	24 GB	
1-64 (16k LDEV)	Apply	Apply	—	Apply	Apply	—	—	—	—	—	—	32 GB	
1-64 (16k LDEV)	Apply	Apply	—	Apply	—	—	Apply	—	—	—	—	32 GB	
1-64 (16k LDEV)	Apply	Apply	—	—	Apply	—	Apply	—	—	—	—	32 GB	
1-255 (64k LDEV)	Apply	Apply	Apply	Apply	—	Apply	—	—	—	Apply	Apply	32 GB	
1-255 (64k LDEV)	Apply	Apply	Apply	—	Apply	Apply	—	—	—	Apply	Apply	32 GB	
1-255 (64k LDEV)	Apply	Apply	Apply	—	—	Apply	Apply	—	—	Apply	Apply	32 GB	
1-64 (16k LDEV)	Apply	Apply	—	Apply	Apply	—	Apply	—	—	—	—	40 GB	
1-64 (16k LDEV)	Apply	Apply	—	—	—	—	Apply	Apply	—	—	—	40 GB	
1-255 (64k LDEV)	Apply	Apply	Apply	Apply	Apply	Apply	—	—	—	Apply	Apply	40 GB	
1-255 (64k LDEV)	Apply	Apply	Apply	—	Apply	Apply	Apply	—	—	Apply	Apply	40 GB	
1-255 (64k LDEV)	Apply	Apply	Apply	Apply	—	Apply	Apply	—	—	Apply	Apply	40 GB	
1-64 (16k LDEV)	Apply	Apply	—	Apply	—	—	Apply	Apply	—	—	—	48 GB	

Number of control unit	Determining factor of SM capacity										iSCSI	DC	SM capacity
	Software <sup>1</sup>					64KL DEV extension	HDP/HDT/AF extension						
	SI/VM/NDM	HDP/TI/FC	TPF	TC/UR/GAD	HDT/AF		1	2	3				
1-64 (16k LDEV)	Apply	Apply	—	—	Apply	—	Apply	Apply	—	—	—	—	48 GB
1-255 (64k LDEV)	Apply	Apply	Apply	Apply	Apply	Apply	Apply	—	—	Apply	Apply	—	48 GB
1-255 (64k LDEV)	Apply	Apply	Apply	—	—	Apply	Apply	Apply	—	Apply	Apply	—	48 GB
1-64 (16k LDEV)	Apply	Apply	—	Apply	Apply	—	Apply	Apply	—	—	—	—	56 GB
1-64 (16k LDEV)	Apply	Apply	—	—	—	—	Apply	Apply	Apply	—	—	—	56 GB
1-255 (64k LDEV)	Apply	Apply	Apply	Apply	—	Apply	Apply	Apply	—	Apply	Apply	—	56 GB
1-255 (64k LDEV)	Apply	Apply	Apply	—	Apply	Apply	Apply	Apply	—	Apply	Apply	—	56 GB
1-64 (16k LDEV)	Apply	Apply	—	Apply	—	—	Apply	Apply	Apply	—	—	—	64 GB
1-64 (16k LDEV)	Apply	Apply	—	—	Apply	—	Apply	Apply	Apply	—	—	—	64 GB
1-255 (64k LDEV)	Apply	Apply	Apply	—	—	Apply	Apply	Apply	Apply	Apply	Apply	—	64 GB
1-255 (64k LDEV)	Apply	Apply	Apply	Apply	Apply	Apply	Apply	Apply	—	Apply	Apply	—	64 GB
1-64 (16k LDEV)	Apply	Apply	—	Apply	Apply	—	Apply	Apply	Apply	—	—	—	72 GB
1-255 (64k LDEV)	Apply	Apply	Apply	Apply	—	Apply	Apply	Apply	Apply	Apply	Apply	—	72 GB

Number of control unit	Determining factor of SM capacity										iSCSI	DC	SM capacity
	Software <sup>1</sup>					64KL DEV extension	HDP/HDT/AF extension						
	SI/VM/NDM	HDP/TI/FC	TPF	TC/UR/GAD	HDT/AF		1	2	3				
1-255 (64k LDEV)	Apply	Apply	Apply	—	Apply	Apply	Apply	Apply	Apply	Apply	Apply	Apply	72 GB
1-255 (64k LDEV)	Apply	Apply	Apply	Apply	Apply	Apply	Apply	Apply	Apply	Apply	Apply	Apply	80 GB

**1.** Software includes the following applications:

- DC: Deduplication and Compression
- FC: Compatible FlashCopy® V2
- GAD: global-active device
- HDP: Hitachi Dynamic Provisioning
- HDT: Hitachi Dynamic Tiering
- NDM: nondisruptive migration
- SI: ShadowImage®
- TC: TrueCopy
- TI: Thin ImageVolume Migration V2
- SM: Shared memory
- TPF: Transaction Processing Facility
- UR: Universal Replicator
- VM: Volume Migration V2

**2.** The required cache memory capacity is determined by the storage capacity and the number of Processor Blades.

## Cache flash memory

The cache flash memory (CFM) is contained in the cache backup modules in the controller, along with the cache backup batteries. Similar to the cache memory, a CFM feature consists of a pair for redundancy purposes. The CFM backup the cache in case of power or component failure. The following figure shows two CPAs (2-3 and 1-4).

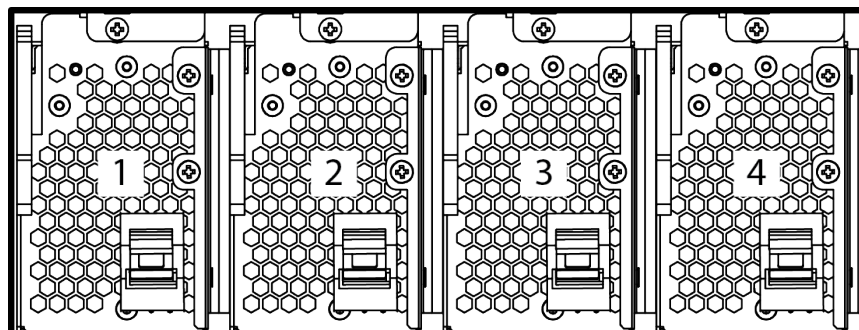

## Cache flash memory operation

Each CFM blade connects directly to its corresponding CPA blade and backs up the data in that CPA blade if power fails. When data that is not stored on disk is written to the cache, it is written to one blade of the CPA and mirrored to the other. If one CFM fails, or if one phase of the power fails, the other CFM backs up the mirrored data from its corresponding CPA blade and data is not lost. In the unlikely event where a CFM has failed and a full power failure occurs, the other CFM backs up the mirrored data from the CPA without any loss of data.

## Cache flash memory capacity

The recommended size of the installed cache flash memory depends on the size of the cache memory, and is automatically selected when defining the configuration for the system.

The following table shows CFM capacities per controller with both small and large cache memory backup assemblies.

Number of controllers	Number of CFM features (pairs of boxes)	Memory module size	CFM size <sup>1</sup>
1	1 CFM	128 GB	256 GB
		256 GB	512 GB
	2 CFMs	128 GB	512 GB
		256 GB	1 TB
2	1 CFM	128 GB	512 GB

Number of controllers	Number of CFM features (pairs of boxes)	Memory module size	CFM size <sup>1</sup>
	2 boxes / SSDs	256 GB	1 TB
	2 CFMs	128 GB	1 TB
	4 boxes / SSDs	256 GB	2 TB
<b>Notes:</b> 1. SDD sizes must be the same in all CFM. Cache must be distributed evenly across CFMs and controllers.			



**Note:** The small CFM SSDs (128 GB) can be installed in the large cache backup, allowing for easier and less expensive upgrades.

## Service Processor

The service processor (SVP) is a hardware component that performs modifications of settings, reports statistical information about device availability, and provides maintenance accessibility to the storage system.

The controller chassis is equipped with a primary and an optional secondary service processor. The primary SVP is active while the secondary SVP is duplicated and remains on active-standby in case of a failure. Employing a duplicate SVP configuration provides redundancy and prevents the loss of use of its monitoring function. If a failure occurs, the standby SVP is automatically switched into operation. The switching operation time is approximately three minutes.

The table lists the technical specifications of the service processor.

Component	Specifications
Operating System	Windows 7 / Windows 10 IoT Enterprise*
CPU	Intel Celeron P4505 1.86 GHz
Internal Memory	4 GB
Disk drive	300 GB (3.5-inch HDD)
LAN	On-Board 10Base-T/ 100Base-TX / 1000Base-T x 2 Port
HUB	On-Board 10Base-T/ 100Base-TX / 1000Base-T x 19 Port

Component	Specifications
Modem	None
Serial port	RS-232-C
USB	Version 2 x 4 ports
PC Card Slot	None
*The SVP must be on firmware version 80-06-42 or later to support the Windows 10 IoT Enterprise operating system.	

## Chapter 3: Hardware architecture

The basic system architecture of a VSP G1000, VSP G1500, and VSP F1500 single controller includes virtual storage directors (microprocessors) are shared across the cache, front-end directors (host adapters), and back-end directors (disk adapters), providing processing power where and when it is needed, without latency or interruption.

This architecture significantly increases the I/O throughput, up to three times the speed of the VSP system. The system provides a highly granular upgrade path, allowing the addition of drives to the drive chassis, and components such as virtual storage directors to the controller chassis as storage needs increase.

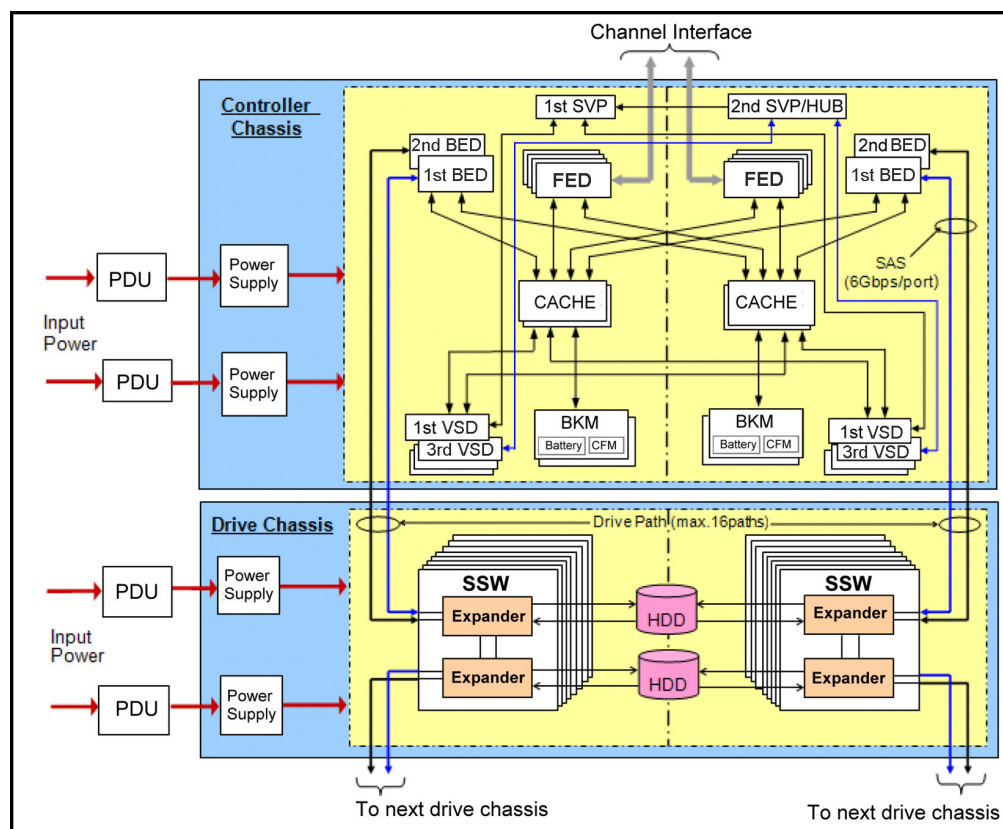

### VSP G1000, VSP G1500, and VSP F1500 RAID implementation

The benefits of RAID technology are low cost, high reliability, and high I/O performance of data storage devices. To gain these benefits, this storage system supports RAID levels 1, 5, and 6.

## Array groups and RAID levels

An array group (also called parity group) is the basic unit of storage capacity for the storage system. In RAID 1, an array group is a set of four physical drives where one drive is installed in the same location in each of four contiguous disk trays in the same drive chassis. The following figure shows part of an SFF drive chassis where two RAID 1 array groups are set up. RAID 1 is shown by yellow rectangles. The RAID 2 is shown by the red rectangles.

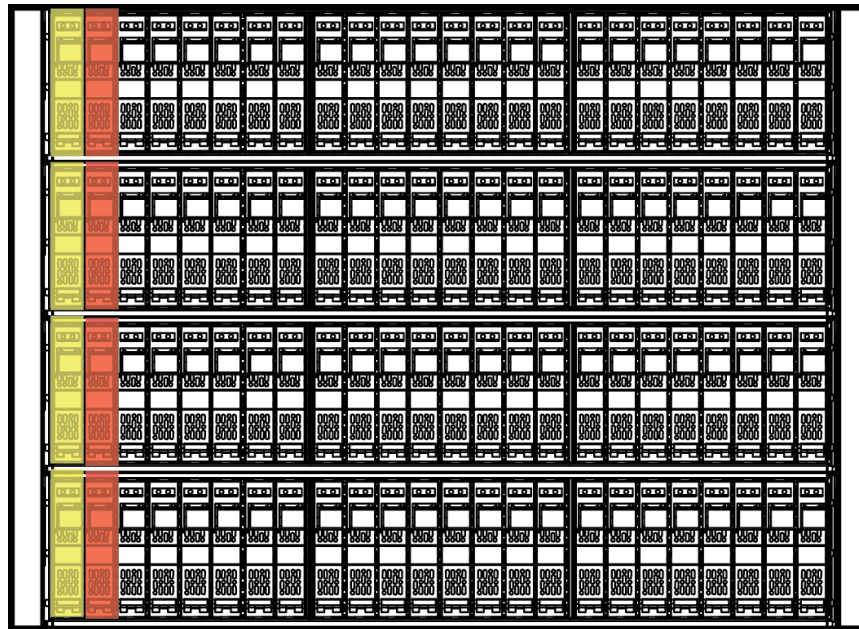

**Figure 8 RAID group example**

The storage system supports the following RAID levels: RAID 1, RAID 5, and RAID 6. When configured in four-drive RAID 5 parity groups (3D+1P), 75% of the raw capacity is available to store user data, and 25% of the raw capacity is used for parity data.

### RAID 1

The following two figures illustrate RAID 1 configurations. The tables following the figures describe each configuration.



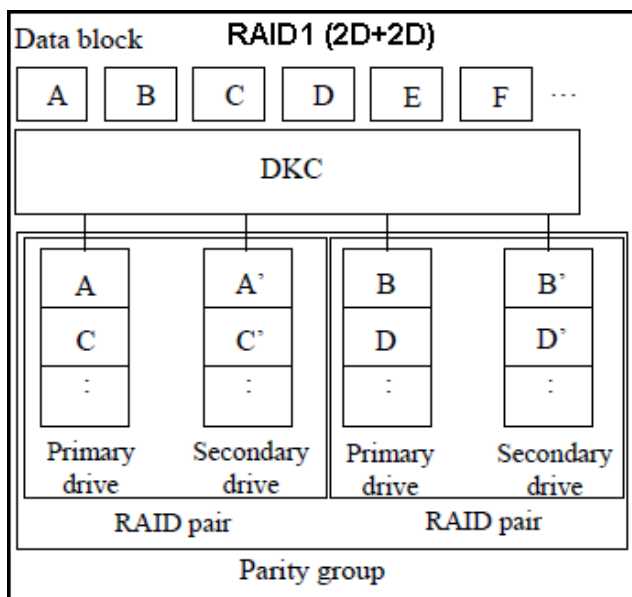

Item	Description
Description	Mirror disks (duplicated writes). Two disk drives, plus primary and secondary disk drives, compose a RAID pair (mirroring pair) and the identical data is written to the primary and secondary disk drives. The data is distributed on the two RAID pairs.
Advantage	RAID 1 is highly usable and reliable because of the duplicated data. It has higher performance than ordinary RAID 1 (when it consists of two disk drives) because it consists of the two RAID pairs.
Disadvantage	Requires disk capacity twice as large as the user data.

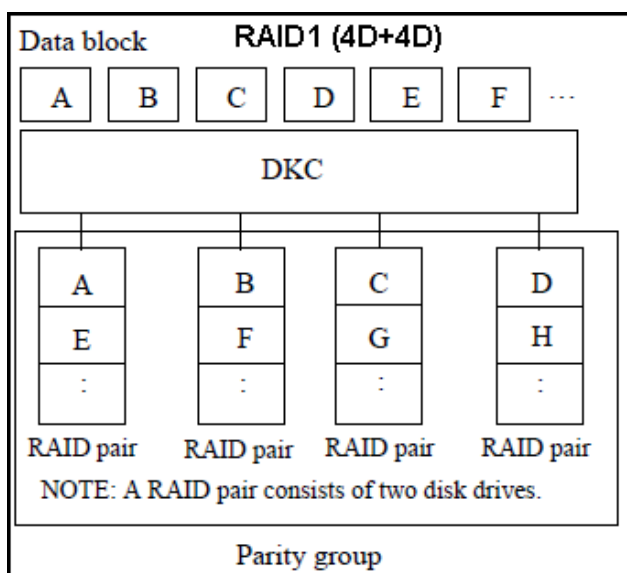

Item	Description
Description	Mirror disks (duplicated writing). The two parity groups of RAID 1(2D+2D) are concatenated and data is distributed on them. In the each RAID pair, data is written in duplicate.
Advantage	This configuration is highly usable and reliable because of the duplicated data. It has higher performance than the 2D+2D configuration because it consists of the four RAID pairs.
Disadvantage	Requires disk capacity twice as large as the user data.

## RAID 5

A RAID 5 array group consists of four or eight drives (3D+1P) or (7D+1P). The data is written across the four drives or eight drives in a stripe that has three or seven data chunks and one parity chunk. Each chunk contains either eight logical tracks (mainframe) or 768 logical blocks (open). This RAID 5 implementation minimizes the write penalty incurred by standard RAID 5 implementations by keeping write data in cache until the entire stripe can be built, and then writing the entire data stripe to the drives. The 7D+1P RAID 5 configuration increases usable capacity and improves performance.

The following two figures illustrate RAID 5 configurations. The tables following the figures describes each configuration.

 **Note:** RAID 5 contains two configurations: 3D+1P configuration (four disk drives) and 7D+1P configuration (eight disk drives). The following diagram shows the 3D+1P configuration. In the 7D+1P configuration, data is arranged in the same way.

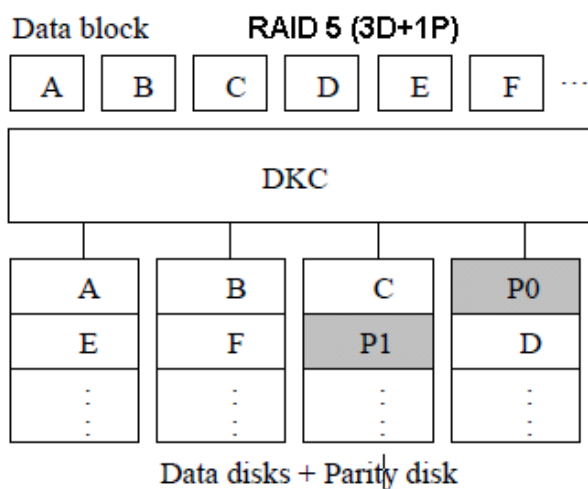

Item	Description
Description	Data is written to multiple disks successively in units of block (or blocks). Parity data is generated from data of multiple blocks and written to disk.
Advantage	RAID 5 supports transaction operations that mainly use small size random access because each disk can receive I/O instructions independently. It can provide high reliability and usability at a comparatively low cost by virtue of the parity data.
Disadvantage	Write penalty of RAID 5 is larger than of RAID 1 because pre-update data and pre-update parity data must be read internally as the parity data is updated when data is updated.

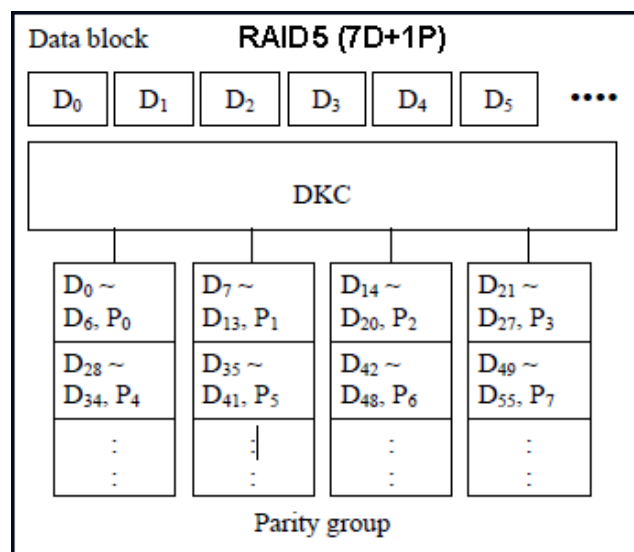

Item	Description
Description	Two or four parity groups (eight drives) are concatenated. The data is distributed and arranged in 16 drives or 32 drives.
Advantage	If a RAID 5 (3D+1P) parity group becomes a performance bottleneck, you might improve performance through the added drives in a RAID 5 (7D+1P) configuration.
Disadvantage	The impact when two drives are blocked is significant because twice or four times the numbers of LDEVs are arranged in the parity group when compared with RAID 5 (3D+1P). However, the chance that the read of the single block in the parity group cannot be performed due to failure is the same as that of RAID 5 (3D+1P).

[Figure 9 Sample RAID 5 3D + 1P Layout \(Data Plus Parity Stripe\) \(on page 68\)](#) shows RAID 5 data stripes mapped across four physical drives. Data and parity are striped across each drive in the array group. The logical devices (LDEVs) are dispersed evenly in the array group, so that the performance of each LDEV within the array group is the same. This figure also shows the parity chunks that are the Exclusive OR (XOR) of the data chunks. The parity chunks and data chunks rotate after each stripe. The total data in each stripe is 2304 blocks (768 blocks per chunk) for Open-systems data. Each of these array groups can be configured as either 3390-x or OPEN-x logical devices. All LDEVs in the array group must be the same format (3390-x or OPEN-x). For Open systems, each LDEV is mapped to a SCSI address, so that it has a track identifier (TID) and logical unit number (LUN).

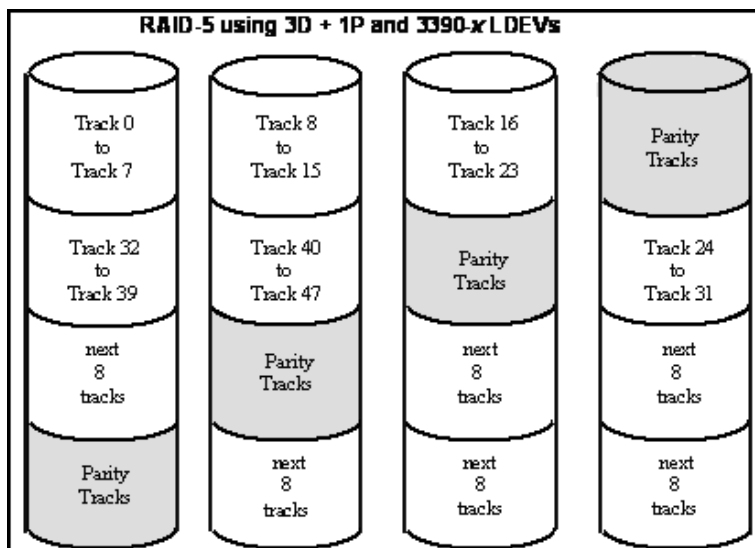

**Figure 9 Sample RAID 5 3D + 1P Layout (Data Plus Parity Stripe)**

## RAID 6

A RAID 6 array group consists of eight drives (6D+2P). The data is written across the eight drives in a stripe that has six data chunks and two parity chunks. Each chunk contains 768 logical blocks.

In RAID 6, data can be assured when up to two drives in an array group fail. Therefore, RAID 6 is the most reliable of the RAID levels.

The following figure illustrates the RAID 6 configuration and the table describes the configuration.



**Note:** RAID 6 contains two configurations: 6D+2P (8 disk drives) and 14D+2P (16 disk drives). The following diagram shows the 6D+2P configuration.

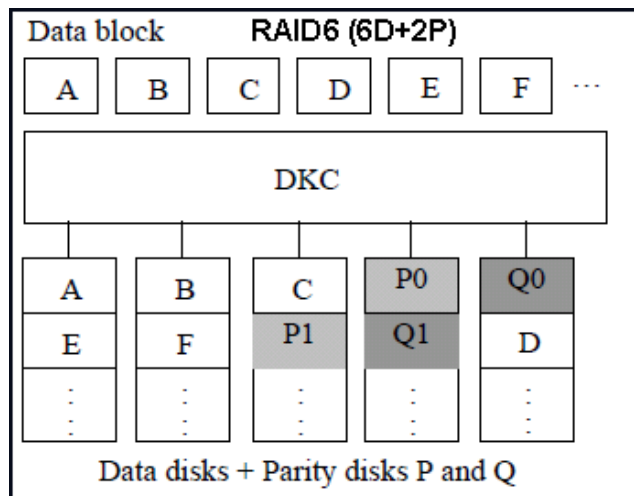

Item	Description
Description	Data blocks are scattered to multiple disks in the same way as RAID 5 and two parity disks, P and Q, are set in each row. Therefore, data can be assured even when failures occur in up to two disk drives in a parity group.
Advantage	RAID 6 is much more reliable than RAID 1 and RAID 5 because it can restore data even when failures occur in up to two disks in a parity group.
Disadvantage	The parity data P and Q must be updated when data is updated, RAID 6 imposes a write heavier than that on RAID 5. Performance of the random writing is lower than RAID 5 when the number of drives makes a bottleneck.

## LDEV striping across array groups

In addition to the conventional concatenation of RAID 1 array groups (4D+4D), the storage system supports LDEV striping across multiple RAID 5 array groups for improved logical unit performance in open-system environments. The advantages of LDEV striping are:

- Improved performance, especially of an individual logical unit, due to an increase in the number of drives that constitute an array group.
- Superior workload distribution: If the workload of one array group is higher than another array group, you can distribute the workload by combining the array groups, thereby reducing the total workload concentrated on each specific array group.

The supported LDEV striping configurations are:

- LDEV striping across two RAID 5 (7D+1P) array groups. The maximum number of LDEVs in this configuration is 1000. See the following figure.
- LDEV striping across four RAID 5 (7D+1P) array groups. The maximum number of LDEVs in this configuration is 2000. See [Figure 11 LDEV striping across four RAID 5 \(7D+1P\) array groups \(on page 71\)](#).

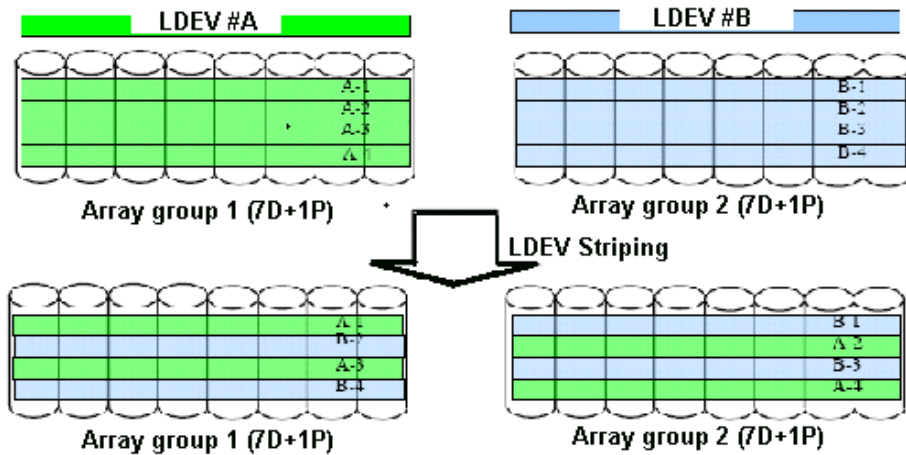

**Figure 10 LDEV striping across two RAID 5 (7D+1P) array groups**

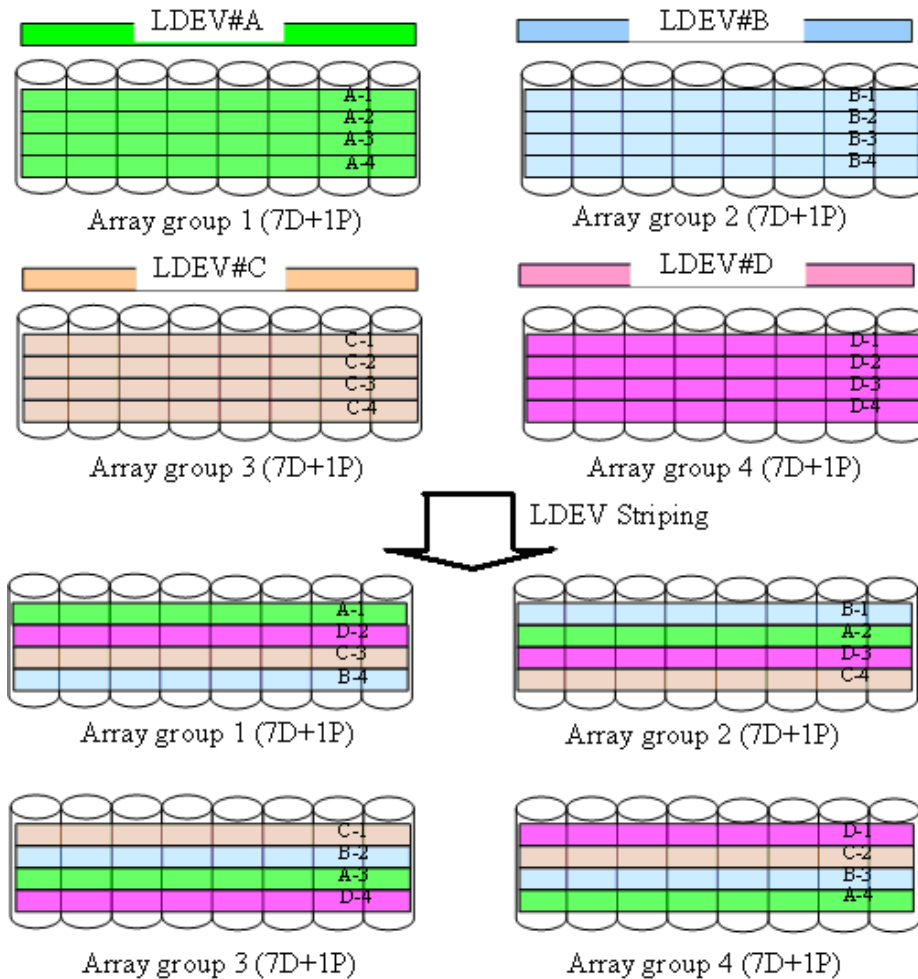

**Figure 11 LDEV striping across four RAID 5 (7D+1P) array groups**

All drives and device emulation types are supported for LDEV striping. LDEV striping can be used with all storage system data management functions.

## Control unit images, logical volume images, and logical units

This section provides information about control unit images (CU), logical volume images (LVI), and logical units (LU).

### CU images

The storage system is configured with one control unit image for each 256 devices (one SSID per 64 LDEVs or 256 LDEVs) and supports a maximum of 255 CU images in the primary logical disk controller (LDKC).

The storage system supports the control unit (CU) emulation type 2107.

The mainframe data management features of the storage system can restrict CU image compatibility.

For more information on CU image support, see the *Mainframe Host Attachment and Operations Guide*, or contact your Hitachi Vantara account team.

## Logical volume images

The VSP G1000, VSP G1500, and VSP F1500 storage systems support the following Mainframe LVI types:

- 3390-3
- 3390-3R
- 3390-9
- 3390-L
- 3390-M



**Note:** The 3390-3 and 3390-3R LVIs cannot be intermixed in the same storage system.

The LVI configuration of the storage system depends on the RAID implementation and physical data drive capacities. To access the LDEVs, combine the logical disk controller number (00), CU number (00-FE), and device number (00-FF). All control unit images can support an installed LVI range of 00 to FF.

For maximum flexibility in LVI configuration, the storage system provides the Virtual LVI feature. Using Virtual LVI, users can configure multiple LVIs under a single LDEV. For further information on Virtual LVI, see the *Provisioning Guide for Mainframe Systems*.

## Logical units

The storage system is configured with OPEN-V logical unit types. The OPEN-V logical unit size can vary from 48.1 MB to 4 TB. For information about other logical unit types (for example, OPEN-9), contact Hitachi Vantara support.

For maximum flexibility in LU configuration, the storage system provides the Virtual LUN feature. Using Virtual LUN, users can configure multiple LUs under a single LDEV. For further information on Virtual LUN, see the *Provisioning Guide for Open Systems*.

## Mainframe operations

This section provides high-level descriptions of mainframe compatibility, support, and configurations.

## Mainframe compatibility and functionality

In addition to full System Managed Storage (SMS) compatibility, the storage system provides the following functions and support in a Mainframe environment:

- Sequential data striping
- Cache fast write (CFW) and DASD fast write (DFW)



- Enhanced dynamic cache management
- Extended count key data (ECKD) commands
- Multiple Allegiance
- Concurrent Copy (CC)
- Peer-to-Peer Remote Copy (PPRC)
- FlashCopy<sup>®</sup>
- Parallel Access Volume (PAV)
- Hyper Parallel Access Volume (HPAV)
- Priority I/O queuing
- Red Hat Linux for IBM<sup>®</sup> S/390<sup>®</sup> and IBM<sup>®</sup> zSeries<sup>®</sup>
- SUSE Linux for IBM<sup>®</sup> S/390<sup>®</sup> and IBM<sup>®</sup> zSeries<sup>®</sup>
- zHyperWrite<sup>™</sup> for DB2<sup>®</sup> (for details, see *Hitachi Virtual Storage Platform G1000, G1500, F1500 Hitachi TrueCopy<sup>®</sup> for Mainframe User Guide*)
- zHPF Extended Distance II (VSP G1000, VSP G1500, and VSP F1500 microcode 80-05-0x or later)
- FICON<sup>®</sup> Dynamic Routing
- FICON<sup>®</sup> Forward Error Correction (VSP G1000, VSP G1500, and VSP F1500 microcode 80-05-0x or later)

## Mainframe operating system support

The VSP G1000, VSP G1500, and VSP F1500 storage systems support most major IBM mainframe operating systems. For more information about supported operating systems, see the mainframe support matrix on [https://support.hds.com/en\\_us/interoperability.html](https://support.hds.com/en_us/interoperability.html).

## Mainframe configuration

After a storage system installation is complete, users can configure the storage system for mainframe operations.

See the following user documents for information and instructions about configuring your storage system for mainframe operations:

- The *Mainframe Host Attachment and Operations Guide*, provides instructions for configuring the storage system for mainframe operations, including FICON attachment, hardware definition, cache operations, and device operations.

For detailed information about FICON connectivity, FICON or Open intermix configurations, and supported HBAs, switches, and directors for VSP G1000, VSP G1500, and VSP F1500, contact customer support.

- The *System Administrator Guide* provides instructions for installing, configuring, and using Device Manager - Storage Navigator to perform resource and data management operations on the storage systems.
- The *Provisioning Guide for Mainframe Systems* provides instructions for converting single volumes (LVs) into multiple smaller volumes to improve data access performance.

## Open-systems operations

This section provides high-level descriptions of open-systems compatibility, support, and configuration for storage systems.

### Open-systems compatibility and functionality

The VSP G1000, VSP G1500, and VSP F1500 storage systems support many features and functions for the open-systems environment, including:

- Compatibility with most iSCSI adapters, Fibre Channel host bus adapters (HBAs), and Fibre Channel-over-Ethernet (FCoE) converged network adapters (CNAs)
- Multi-initiator I/O configurations with multiple host systems attached to the same Fibre Channel interface
- Fibre Channel Arbitrated Loop (FC-AL) topology, supported on ports up to 8 Gbps
- Fibre Channel fabric topology using direct attach point-to-point connections, supported on ports up to 16 Gbps



**Note:** When using 16-Gbps FC front-end director in an FC-AL topology, the transmission speed is limited to 8 Gbps.

- Command tag queuing
- Industry-standard failover and logical volume management software
- SNMP remote storage system management

The global cache feature in VSP G1000, VSP G1500, and VSP F1500 enables any port to have access to any logical unit in the storage system. Each logical unit can be assigned to multiple ports to provide I/O path failover and load balancing (with the appropriate middleware support, such as Hitachi Global Link Manager) without sacrificing cache coherency.

Users should plan for path failover (alternate pathing) to ensure the highest data availability. The logical units can be mapped for access from multiple ports or multiple target IDs. The number of connected hosts is limited only by the number of Fibre Channel ports installed and the requirement for alternate pathing within each host. If possible, the primary path and alternate paths should be attached to different channel cards.

## Open-systems host platform support

The VSP G1000, VSP G1500, and VSP F1500 storage systems support most major open-system operating systems, including Windows<sup>®</sup>, Solaris, IBM AIX<sup>®</sup>, Linux, HP-UX, and VMware. For complete information about supported operating systems, visit [https://support.hds.com/en\\_us/interoperability.html](https://support.hds.com/en_us/interoperability.html).

For a complete list of the storage system user guides, including the *Open-Systems Host Attachment Guide*, see the *Product Overview*.

## System configuration

After installing the storage system is complete, you can configure the storage system for open-systems operations.

Refer to the following documents for information and instructions about configuring your storage system for open-systems operations:

- The *Open-Systems Host Attachment Guide* provides information and instructions to configure the storage system and data storage devices for attachment to the open-systems hosts.



**Note:** The storage system queue depth and other parameters are adjustable. See the *Open-Systems Host Attachment Guide* for queue depth and other requirements.

- The *System Administrator Guide* provides instructions for installing, configuring, and using Device Manager - Storage Navigator to perform resource and data management operations on the storage system.
- The *Provisioning Guide for Open Systems* describes and provides instructions for configuring the storage system for host operations, including FC port configuration, LUN mapping, host groups, host modes and host mode options, and LUN security.

Each FC port on the storage system provides addressing capabilities for up to 2,048 LUNs across as many as 255 host groups, each with its own LUN 0, host mode, and host mode options. Multiple host groups are supported using LUN security.

- The *Hitachi Alert Notification Guide* describes the SNMP API interface for the storage systems and provides instructions for configuring and performing SNMP operations.
- The *Provisioning Guide for Open Systems* provides instructions for configuring multiple custom volumes (logical units) under single LDEVs on the VSP G1000, VSP G1500, and VSP F1500.

## Host modes and host mode options

The VSP G1000, VSP G1500, and VSP F1500 storage systems connect multiple server hosts of different platforms to each of its ports.

When your system is configured, the hosts connected to each port are grouped by host group or by target. For example, if Solaris and Windows hosts are connected to separate iSCSI or FC ports, or through a switch to a single iSCSI or FC port, a host group is created for the Solaris hosts and another host group is created for the Windows hosts. The appropriate host mode and host mode options are assigned to each host group. The host modes and host mode options enhance compatibility with supported platforms and environments.

Use Device Manager - Storage Navigator to configure host groups, host modes, and host mode options. For more information about host groups, host modes, and host mode options, see the *System Administrator Guide*.

## Device Manager - Storage Navigator program

Device Manager - Storage Navigator is the GUI that accesses the features in the microcode.

The GUI is also used to set up and monitor the storage system. It can be installed on a PC, laptop, or workstation. It communicates via a LAN to the SVP in the storage system. The SVP obtains storage system configuration and status information and sends user-initiated commands to the storage system. Device Manager - Storage Navigator displays detailed storage system information and allows you to configure and perform storage operations on the system.

Device Manager - Storage Navigator is a Java<sup>®</sup> applet program that can run on any machine that supports a Java Virtual Machine (JVM). A PC hosting the Device Manager - Storage Navigator software is called a remote console. Each time a remote console accesses and logs on to the SVP, the Device Manager - Storage Navigator applet is downloaded from the SVP to the remote console. The following figure shows the remote console and SVP configuration for Device Manager - Storage Navigator.

For more information about Device Manager - Storage Navigator, see the *System Administrator Guide*.

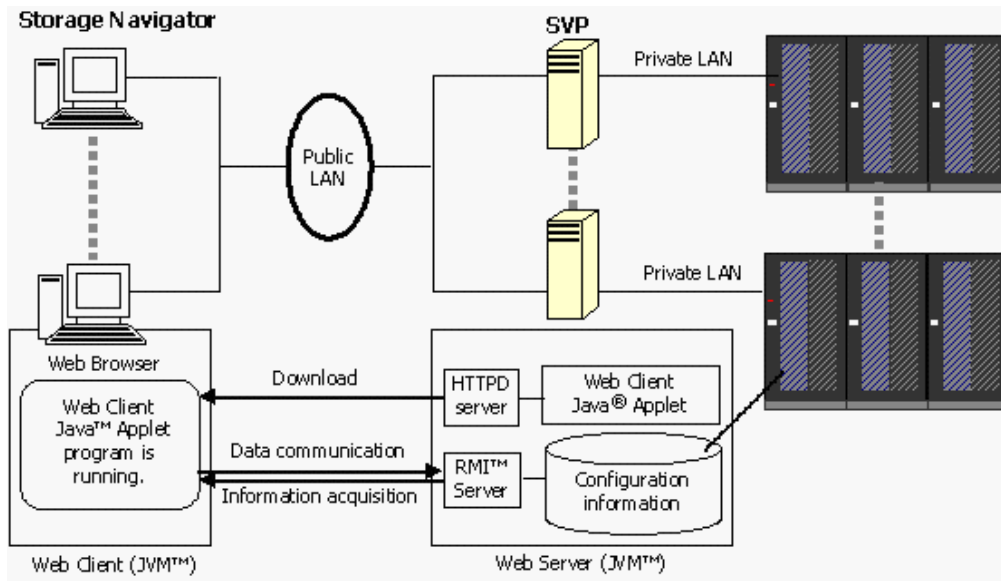

**Figure 12 Device Manager - Storage Navigator and SVP configuration**

---

## Chapter 4: Site preparation specifications

The following guidelines for installing storage systems provide site and system requirements, and specifications.



**Note:** For more information about installation requirements and system configurations, contact customer support.

### Responsibilities

The responsibilities for site planning and preparation are shared by the system users and Hitachi Vantara support. The required installation planning tasks must be scheduled and completed to ensure a successful and efficient installation of the storage system.



**Note:** The storage system must be installed by trained Hitachi Vantara personnel or trained authorized service providers. The storage system is not a customer-installable product.

### Customer responsibilities

You are responsible for completing the following tasks and preparing your site for installation of the storage system.

- Understand the applicable safety requirements associated with installing a storage system.
- Understand the installation requirements for the storage system. You can use the information in this manual to determine the specific requirements for your installation. As needed, review the *Product Overview* to familiarize yourself with the components, features, and functions of the storage system.
- Verify the installation site meets all installation requirements. A checklist is included in this section to help you with this task.
- Meet electrical power prerequisites and provide electrical hardware, including cables, connectors and receptacles for connecting the storage system to site power.
- If necessary, work with Hitachi Vantara support to create an installation plan. Allow enough time to complete any changes to the plan, so your site is ready when the equipment arrives.

## Hitachi Vantara responsibilities

Hitachi Vantara support is responsible for completing the following tasks:

- Provide proper assistance during the installation planning process for your specific site and operational configuration.
- Coordinate Hitachi Vantara resources to ensure a successful installation and configuration of the storage system.

## Site preparation checklist

The following checklist can help you ensure that your site meets all requirements to install a storage system. You can make copies of this checklist for each installation you perform and check each step after it has been performed. Completing this checklist can help ensure smooth and efficient installation of a storage system.

### Definition of terms

#### Equipment

The hardware delivered to the customer site that includes the storage system components. The system can be installed in a Hitachi rack when delivered or assembled on site. The delivered equipment can include only the system components if the customer supplies a standard 19-inch rack. Rack specifications are contained in the *Hitachi Universal V2 Rack Reference Guide*.

#### Location

The specific location in the data center (area or *footprint* on the floor) where the storage system is installed.

User information	
Company	
Address	
Contact	
Phone	
Mobile	
Email	
Contact	
Phone	
Mobile	
Email	

User information	
Hitachi Vantara Information	
Contact	
Phone	
Mobile	
Email	
Contact	
Phone	
Mobile	
Email	
Notes	

Preinstallation checklist	Yes	No
Safety requirements See <a href="#">Safety requirements (on page 168)</a> .		
Does the data center provide appropriate fire protection for the storage systems?		
Is the data center free of hazards such as cables that obstruct access to the equipment?		
Delivery requirements See <a href="#">General site requirements (on page 82)</a> .		
Is the receiving area adequate for equipment delivery, unloading, and unpacking?		
Are all doors, hallways, elevators, and ramps wide enough and high enough to allow the equipment to be moved from the receiving area to the installation area?		
Can the floors, elevators, and ramps support the weight of the equipment? See <a href="#">General site requirements (on page 82)</a> .		
Storage requirements See <a href="#">System storage requirements (on page 83)</a> .		



Preinstallation checklist		Yes	No
If the equipment will be stored after delivery and prior to installation, does the storage location meet the environmental requirements for storing the storage system?			
Facilities requirements See <a href="#">Data center requirements (on page 84)</a> .			
Does the data center have a raised floor?			
Does the location meet the requirements for service clearance and cable routing (for example, floor cutouts)? See <a href="#">Equipment clearances (on page 82)</a> .			
Does the installation site meet the floor load rating requirements?			
Power requirements See <a href="#">#unique 85</a> .			
Does the data center meet the AC input power requirements? See <a href="#">Power connection (on page 83)</a> and <a href="#">#unique 85</a> .			
Does the data center meet the circuit breaker and plug requirements? See <a href="#">Data center requirements (on page 84)</a> .			
Is the customer-supplied hardware such as connectors, receptacles, and cables ready for the installation?			
Environmental requirements See <a href="#">Environmental specifications (on page 147)</a> .			
Does the data center meet the following operational environmental requirements for the storage system?			
	Temperature		
	Humidity		
	Altitude		
	Air flow		
Does the data center provide adequate protection for a storage system from the following?			
	Electrostatic discharge		
	Electrical/radio frequency interference		
	Dust, pollution, and particulate contamination		

Preinstallation checklist	Yes	No
Does the data center provide adequate acoustic insulation to operate the storage system?		
Operational requirements See <a href="#">Operational requirements (on page 85)</a> .		
Does the data center provide a LAN for Device Manager - Storage Navigator?		
Does the location meet the cable length requirements for the front-end module?		
Does the location meet the requirements for attaching external storage?		

## General site requirements

The customer site must accommodate the delivery and movement of the equipment from the receiving dock to the installation location in the data center.

## Equipment clearances

### Receiving area

The receiving dock, storage area, and receiving area must be large enough to allow movement of and access to crated or packed equipment.

### Other areas

The hallways, doorways, ramps and elevators must be wide enough to allow a single unpacked rack to be moved to the installation location. If there is insufficient space for unpacking, the storage systems are typically unpacked in the receiving area and the individual racks with pre-installed equipment are rolled into the data center. For information about rack dimensions, refer to the *Hitachi Universal V2 Rack Reference Guide*.

## Equipment weight

The floors, elevators, and ramps must be able to support the weight of the delivered equipment as it is moved to the installation location. Spreader plates can be a prerequisite for distributing the load and protecting the floor as the equipment is moved from the receiving area to the installation location. Consult the system bill of materials to establish the approximate weight of the equipment.

The weight for a fully configured 2-controller, 6-rack storage system can reach 6,146 pounds / 2,917 kilograms. The exact weight of the equipment depends on the storage system configuration. [#unique\\_89](#) provides weights of typical system configurations.

**Note:**

The data in [#unique\\_89](#) was recorded from measurements of a system in a controlled environment.

To calculate the power draw, current draw, and heat output of a specific system, see [#unique\\_89](#) or use the weight and power calculator at the following URL: <http://www.hds.com/go/weight-and-power-calculator>.

Contact technical support if you need assistance using this tool.

## System storage requirements

If the equipment must be stored after delivery and prior to installation, the storage location must meet certain storage environmental requirements. See [#unique\\_90](#) for more details.

## Grounding

The site and site equipment must meet the following grounding requirements:

- An insulated grounding conductor that is identical in size and insulation material and thickness to the grounded and ungrounded branch-circuit supply conductors. It must be green, with or without yellow stripes, and must be installed as a part of the branch circuit that supplies the unit or system.
- Connect the grounding conductor to earth ground at the service equipment or other acceptable building earth ground. For a high rise steel-frame structure, this can be the steel frame.
- The receptacles in the vicinity of the unit or system must include a ground connection. The grounding conductors serving these receptacles must be connected to earth ground at the service equipment or other acceptable building earth ground.

## Power connection

The AC power input for the storage system has a duplex PDU structure that allows the rack-installed equipment to remain powered on if power is removed from one of the two power distribution units (PDLs).



**Note:** Site power can be connected to the PDUs at either the top or bottom of the racks.

### PDU plugs, circuit breakers, and receptacles

The PDU plugs must be appropriate for the power sources at the installation sites. The following table lists the plugs on the end of the PDU power cords. The power distribution panel at the installation site must have receptacles that match these plugs.

Required number of plugs in each PDU per chassis:

- Controller chassis: 4
- Drive chassis:
  - SFF: 8
  - LFF: 16
  - FMD: 8

Required number of PDUs per rack:

- Controller rack:
  - Single phase: 4
  - Three phase: 2
- Drive rack:
  - Single phase: 4
  - Three phase: 2

## Data center requirements

The data center must meet the following requirements. Detailed mechanical, electrical, and environmental requirements are listed in the following table.

**Table 13 Data center requirements**

Item	Description
General	The data center must provide appropriate power, air conditioning, cabling, and fire protection.
Temperature	The data center must maintain ambient temperature from 50°F (10°C) to 95°F (35°C).
Humidity	The data center must maintain ambient humidity from 20% to 80%, noncondensing.
ESD	The data center must provide adequate protection from electrostatic discharge (ESD).
Electrical interference	The data center must provide adequate protection from electrical/radio frequency interference.
Contamination	The data center must provide adequate protection from dust, pollution, and particulate contamination.
Acoustics	The data center must provide adequate acoustic insulation for operating the system.

Item	Description
User-supplied hardware	Includes cables, connectors, and power receptacles that must be available and ready when the system is installed.
User-supplied software	Includes operating systems, supported by the storage system, on the host and system management console.

## Operational requirements

The operational requirements for the storage system include:

- LAN for Device Manager - Storage Navigator

Device Manager - Storage Navigator communicates with the storage system over a LAN to obtain system configuration and status information and send user commands to the storage system. Device Manager - Storage Navigator is an integrated interface for all resource manager components.

- Cable length for front-end directors

The following table lists the cable length requirements for the front-end directors in the storage system.

**Table 14 Maximum cable length (shortwave)**

DataTransferRate	OM2 (50/125 f/m multi-mode fiber)	OM3 (50/125 f/m laser optimized multi-mode fiber)	OM4 (50/125 f/m laser optimized multi-mode fiber)
MBps	feet / meters	feet / meters	feet / meters
200	984.3 / 300	1640.4 / 500	N/A
400	492.1 / 150	1246.7 / 380	1312.4 / 400
800	164 / 50	492.1 / 150	623.4 / 190
1600	118 / 36	328 / 100	410.1 / 125

- External data storage

If you plan to attach external storage to the storage system, make sure to include the appropriate power and space requirements before attaching the external storage.

## Third-party rack support for VSP G1000, VSP G1500, and VSP F1500 storage systems

You must obtain permission to install VSP G1000, VSP G1500, and VSP F1500 storage systems into a third-party rack.

Contact your Hitachi Vantara account team or customer support for more information.

## Service clearance, floor cutout, and floor load rating

This section describes the service clearance requirements for the storage system, based on the clearance and required floor cutouts for cabling.

- Make sure that the service clearance for maintenance is available.
- Do not use the clearance space for storage
- The floor cutout area and dimensions correspond to 19-inch rack specifications
- Hitachi Vantara recommends that you install a grid panel (air vent in floor) at least 450 x 450 mm on the front side of the rack.
- The floor must have a load rating as shown in the following table.

**Table 15 Floor load rating**

	Minimum Capacity	Maximum Capacity
Per square foot	62.5 lb (28.5 kg)	146 lb (66.25 kg)
Per square meter	660 lb (300 Kg)	1,540 lb (700 Kg)



**Note:** For safe and efficient maintenance operations, clearances should be made as large as possible. Actual clearances for installation should be determined after consulting with the site/facilities manager, as the clearances can vary, depending on building conditions.

## Single-rack configuration

The following figure shows the service clearances for a single-rack configuration.

Service clearances for a one-rack, single-controller system

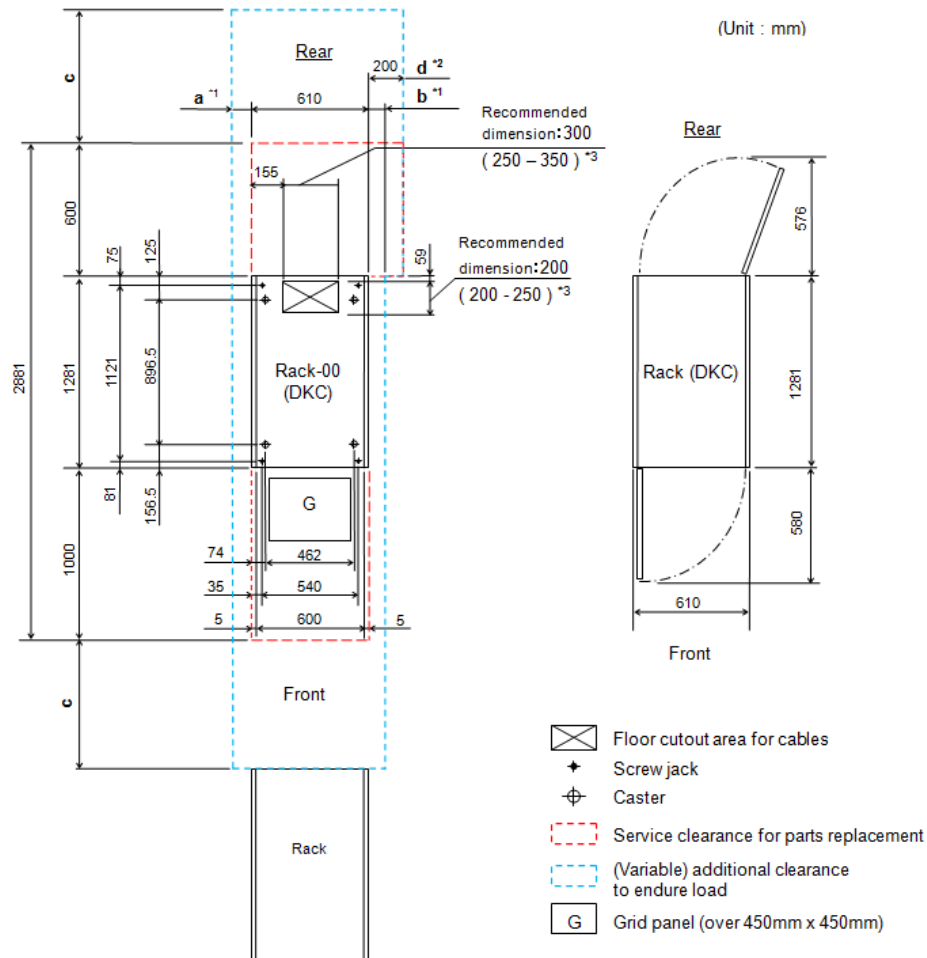

Clearance (a+b) is based on the floor load rating and the clearance (c). Floor load rating and required clearances are shown in the table below. Clearance (d) is required over 200mm so as to open the rear door. In case that clearance (d) is less than clearance (b), give priority to clearance (b). Dimensions in parentheses show allowable range of the floor cutout dimensions. Basically, position the floor cutout in the center of the rack. However, the position may be off-center as long as the cutout allows smooth entrance of an external cable (check the relation between the positions of the cutout and the opening on the bottom plate of the rack) and it is within the allowable range.

Table 16 Floor load rating and required clearances for a single-rack configuration

Floor load rating (kg/m <sup>2</sup> )	Required clearance (a+b) m							
	c= -0.3	c=0	c=0.2	c=0.4	c=0.6	c=0.8	c=1.0	c=1.4
Over 700	0	0	0	0	0	0	0	0
600	0.1	0	0	0	0	0	0	0
500	0.3	0.2	0.1	0.1	0	0	0	0
450	0.4	0.3	0.3	0.2	0.1	0.1	0.1	0
400	0.6	0.5	0.4	0.3	0.3	0.3	0.2	0.1
350	0.9	0.7	0.6	0.6	0.5	0.4	0.4	0.3

Floor load rating (kg/m <sup>2</sup> )	Required clearance (a+b) m							
	c= -0.3	c=0	c=0.2	c=0.4	c=0.6	c=0.8	c=1.0	c=1.4
300	1.4	1.1	1.0	0.9	0.8	0.7	0.6	0.5
<b>Notes:</b> <ol style="list-style-type: none"> <li>1. Actual clearances for installation should be determined after consulting with the construction specialist responsible for installations in the building. Clearances can vary depending on the size/layout of the system and building conditions.</li> <li>2. When various configurations of storage systems are arranged in a row, clearance values based on the largest storage system configuration should be used.</li> <li>3. For easier maintenance operations, make clearance (c) as large as possible.</li> </ol>								

## Two-rack, single-controller configuration

The following figure shows the service clearances for a two-rack configuration.



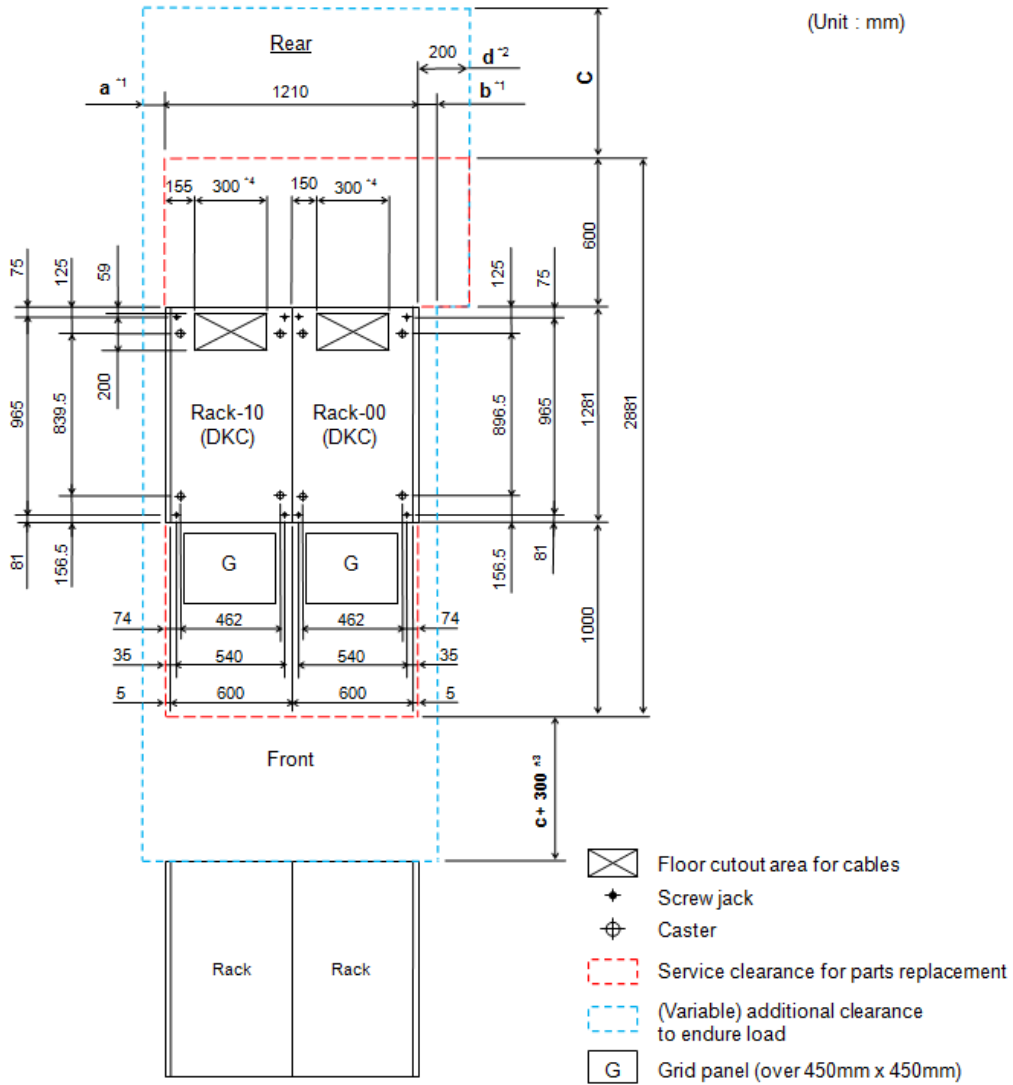

- \*1: Clearance (a+b) is based on the floor load rating and the clearance (c).  
Floor load rating and required clearances are shown in the table below.
- \*2: Clearance (d) is required over 200mm so as to open the front door.  
In case that clearance (d) is less than clearance (b), give priority to clearance (b).

**Figure 13 Service clearances for a two-rack, one-controller system**

**Table 17 Floor load rating and required clearances for a two-rack configuration**

Floor load rating (kg/m <sup>2</sup> )	Required clearance (a+b) m							
	c= -0.3	c20	c=0.2	c=0.4	c=0.6	c=0.8	c=1.0	c=1.4
Over 700	0	0	0	0	0	0	0	0
600	0.1	0	0	0	0	0	0	0
500	0.4	0.2	0.1	0	0	0	0	0
450	0.6	0.4	0.3	0.2	0.1	0	0	0

Floor load rating (kg/m <sup>2</sup> )	Required clearance (a+b) m							
	c= -0.3	c20	c=0.2	c=0.4	c=0.6	c=0.8	c=1.0	c=1.4
400	1.0	0.7	0.6	0.5	0.4	0.3	0.2	0.
350	1.5	1.2	1.0	0.8	0.7	0.6	0.5	0.3
300	2.2	1.8	1.6	1.4	1.3	1.1	1.0	0.8

**Notes:**

1. Actual clearances for installation should be determined after consulting with the construction specialist responsible for installations in the building. Clearances can vary depending on the size/layout of the system and building conditions.
2. When various configurations of storage systems are arranged in a row, clearance values based on the largest storage system configuration should be used.
3. For easier maintenance operations, make clearance (c) as large as possible.

## Two-rack, dual-controller configuration

The following figure shows the service clearances for a two-rack configuration with two controllers.

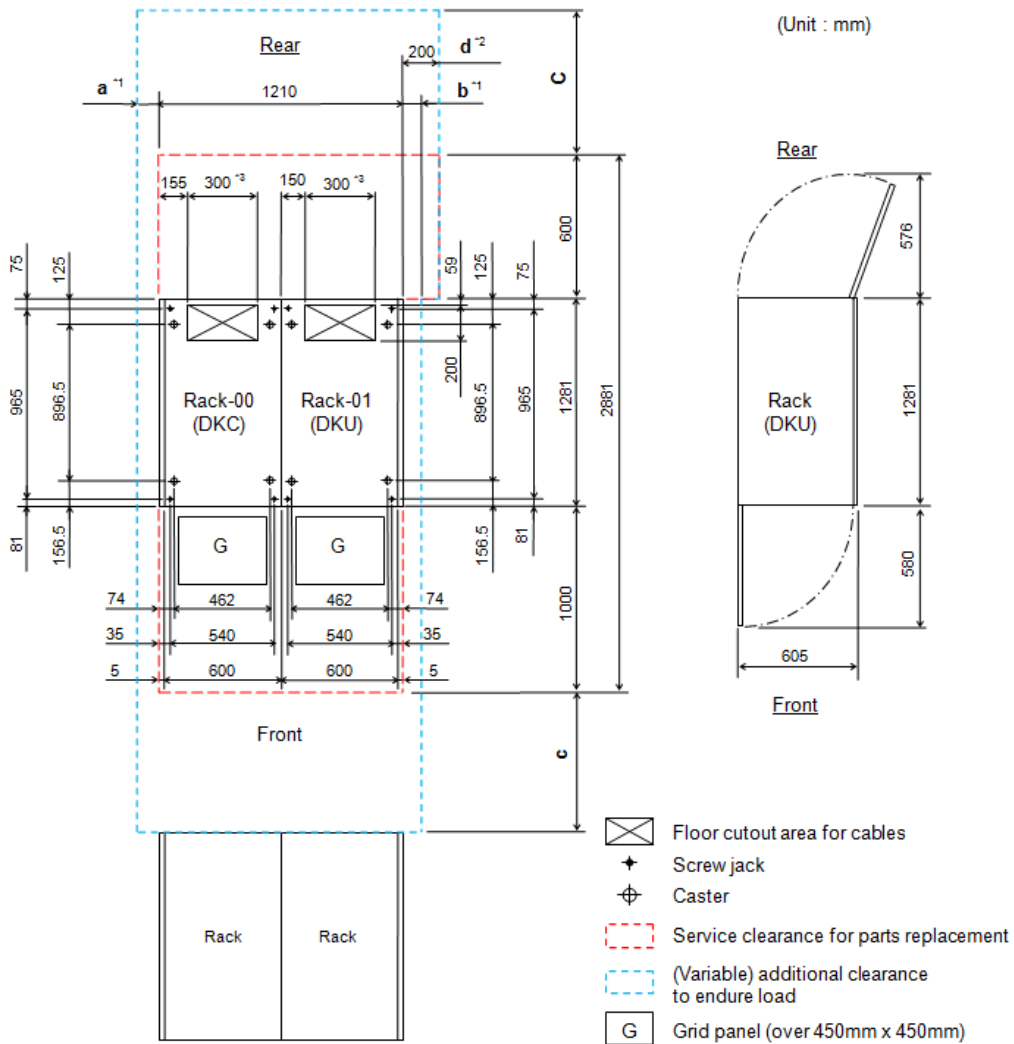

- \*1: Clearance (a+b) is based on the floor load rating and the clearance (c).  
Floor load rating and required clearances are shown in the table below.
- \*2: Clearance (d) is required over 200mm so as to open the rear door.  
In case that clearance (d) is less than clearance (b), give priority to clearance (b).

Figure 14 Service clearances for a two-rack, dual-controller system

Table 18 Floor load rating and required clearances for a two-rack configuration

Floor load rating (kg/m <sup>2</sup> )	Required clearance (a+b) m							
	c= -0.3	c20	c=0.2	c=0.4	c=0.6	c=0.8	c=1.0	c=1.4
Over 700	0	0	0	0	0	0	0	0
600	0.2	0	0	0	0	0	0	0
500	0.6	0.4	0.2	0.1	0.1	0	0	0
450	0.8	0.6	0.5	0.4	0.3	0.2	0.1	0

Floor load rating (kg/m <sup>2</sup> )	Required clearance (a+b) m							
	c= -0.3	c20	c=0.2	c=0.4	c=0.6	c=0.8	c=1.0	c=1.4
400	1.2	0.9	0.8	0.6	0.5	0.4	0.3	0.2
350	1.8	1.4	1.2	1.1	0.9	0.8	0.7	0.5
300	2.6	2.2	1.9	1.7	1.5	1.4	1.0	1.0

**Notes:**

1. Actual clearances for installation should be determined after consulting with the construction specialist responsible for installations in the building. Clearances can vary depending on the size/layout of the system and building conditions.
2. When various configurations of storage systems are arranged in a row, clearance values based on the largest storage system configuration should be used.
3. For easier maintenance operations, make clearance (c) as large as possible.

### Three-rack, single-controller configuration

The following figure shows the service clearances for a three-rack configuration with one controller.

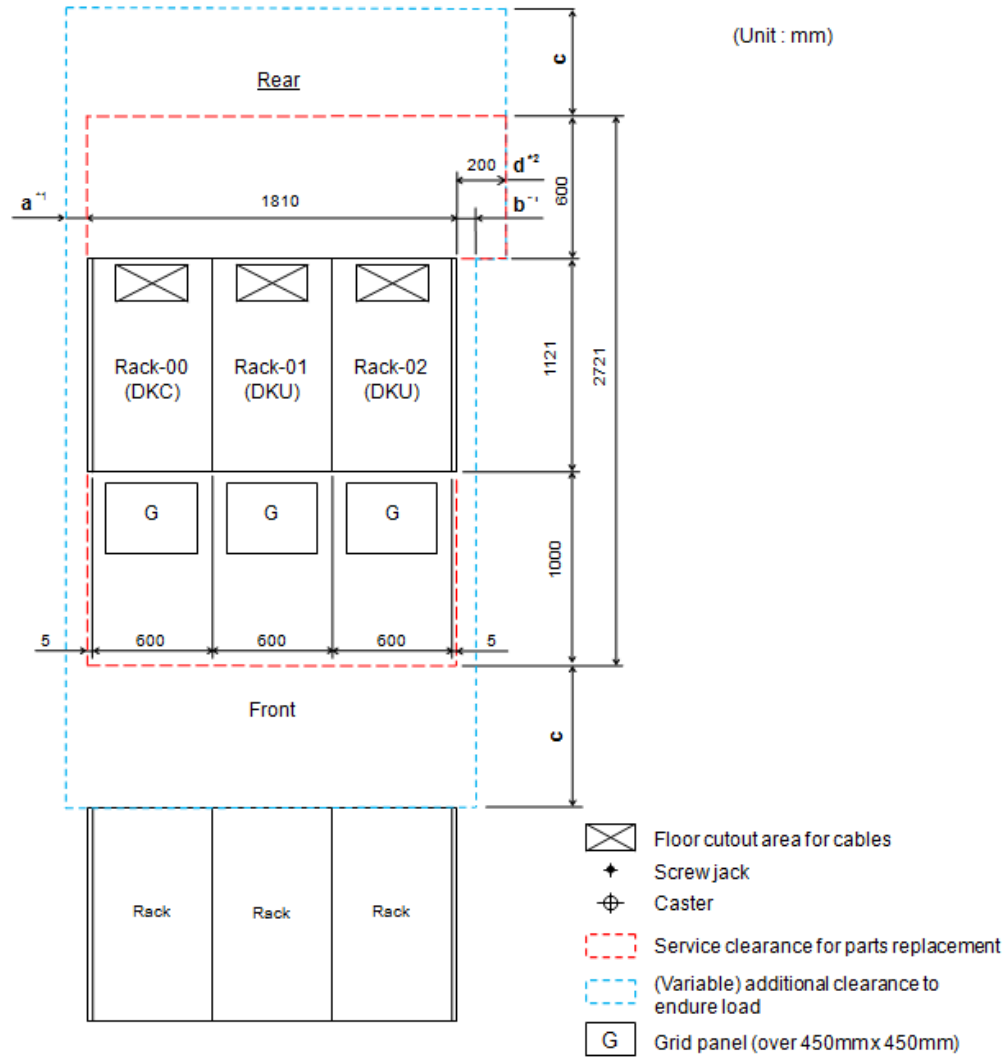

\*1: Clearance ( $a+b$ ) is based on the floor load rating and the clearance ( $c$ ).  
Floor load rating and required clearances are shown in the table below.

\*2: Clearance ( $d$ ) is required over 200mm so as to open the rear door.  
In case that clearance ( $d$ ) is less than clearance ( $b$ ), give priority to clearance ( $b$ ).

Figure 15 Service clearances for a three-rack, single-controller system

Table 19 Floor load rating and required clearances for a three-rack, single-controller configuration

Floor load rating (kg/m <sup>2</sup> )	Required clearance ( $a+b$ ) m							
	$c = -0.3$	$c = 0$	$c = 0.2$	$c = 0.4$	$c = 0.6$	$c = 0.8$	$c = 1.0$	$c = 1.4$
Over 700	0	0	0	0	0	0	0	0
600	0	0	0	0	0	0	0	0
500	0.5	0.2	0.1	0	0	0	0	0

Floor load rating (kg/m <sup>2</sup> )	Required clearance (a+b) m							
	c= -0.3	c=0	c=0.2	c=0.4	c=0.6	c=0.8	c=1.0	c=1.4
450	0.9	0.5	0.4	0.2	0.1	0	0	0
400	1.3	1.0	0.8	0.6	0.4	0.3	0.2	0
350	2.0	1.6	1.3	1.1	0.9	0.8	0.6	0.4
300	3.1	2.6	2.2	2.0	1.7	1.5	1.3	1.0

**Notes:**

1. Actual clearances for installation should be determined after consulting with the construction specialist responsible for installations in the building. Clearances can vary depending on the size/layout of the system and building conditions.
2. When various configurations of storage systems are arranged in a row, clearance values based on the largest storage system configuration should be used.
3. For easier maintenance operations, make clearance (c) as large as possible.

### Three-rack, dual-controller configuration

The following figure shows the service clearances for a three-rack configuration with two controllers.

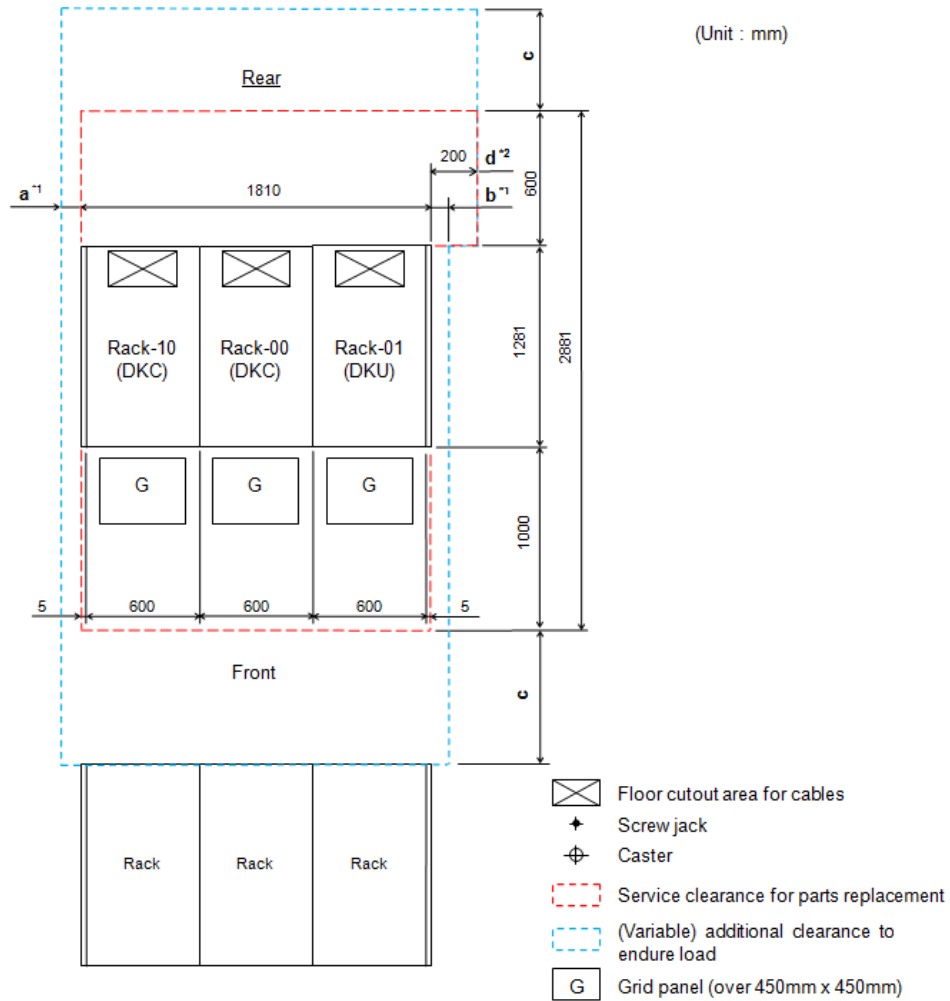

- \*1: Clearance (a+b) is based on the floor load rating and the clearance (c).  
Floor load rating and required clearances are shown in the table below.
- \*2: Clearance (d) is required over 200mm so as to open the rear door.  
In case that clearance (d) is less than clearance (b), give priority to clearance (b).

**Figure 16 Service clearances for a three-rack, dual-controller system**

**Table 20 Floor load rating and required clearances for a three-rack, dual-controller configuration**

Floor load rating (kg/m <sup>2</sup> )	Required clearance (a+b) m							
	c= -0.3	c=0	c=0.2	c=0.4	c=0.6	c=0.8	c=1.0	c=1.4
Over 700	0	0	0	0	0	0	0	0
600	0.2	0	0	0	0	0	0	0
500	0.7	0.4	0.2	0.1	0	0	0	0
450	1.1	0.7	0.5	0.4	0.2	0.1	0	0
400	1.6	1.2	1.0	0.8	0.6	0.5	0.3	0.1

Floor load rating (kg/m <sup>2</sup> )	Required clearance (a+b) m							
	c= -0.3	c=0	c=0.2	c=0.4	c=0.6	c=0.8	c=1.0	c=1.4
350	2.3	1.8	1.6	1.3	1.1	1.0	0.8	0.5
300	3.5	2.9	2.5	2.2	2.0	1.8	1.6	1.2

**Notes:**

1. Actual clearances for installation should be determined after consulting with the construction specialist responsible for installations in the building. Clearances can vary depending on the size/layout of the system and building conditions.
2. When various configurations of storage systems are arranged in a row, clearance values based on the largest storage system configuration should be used.
3. For easier maintenance operations, make clearance (c) as large as possible.

### Four-rack configuration - two controllers (center)

The following figure shows the service clearances for a four-rack, two-controller configuration, with the controllers in the center two racks.



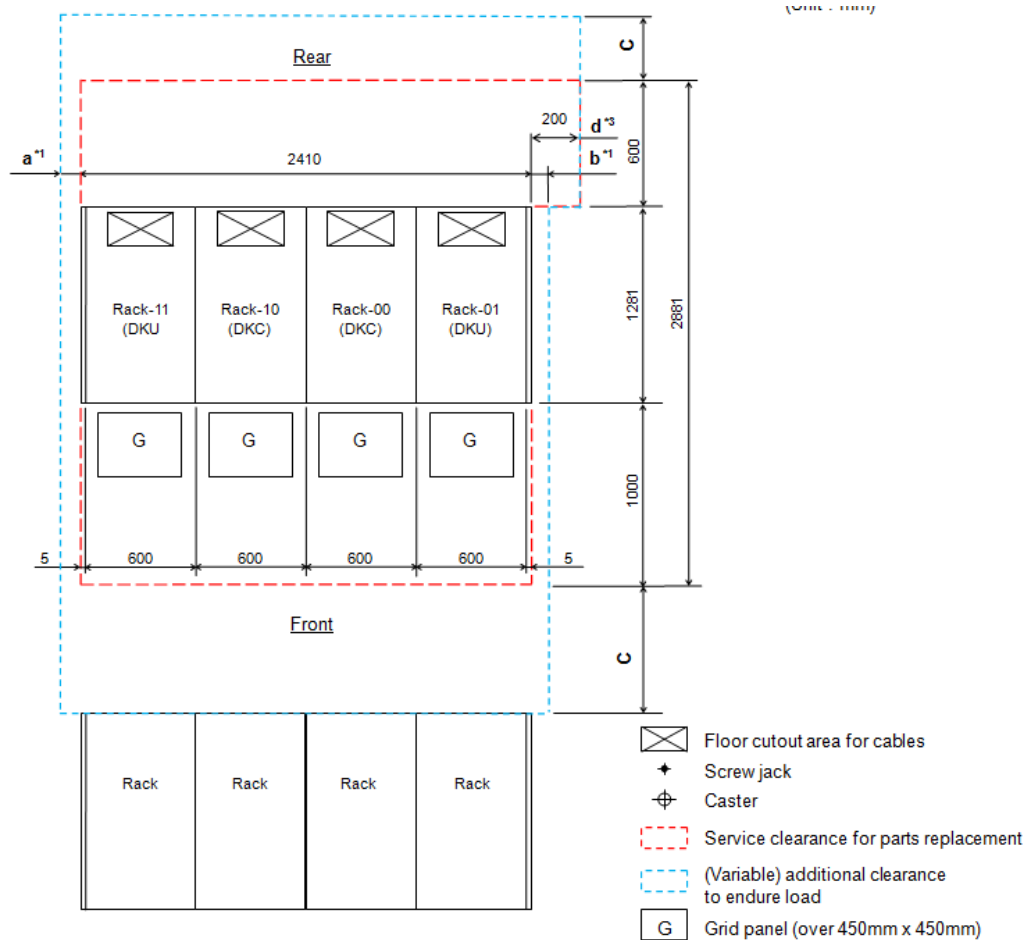

- \*1: Clearance (a+b) is based on the floor load rating and the clearance (c).  
Floor load rating and required clearances are shown in the table below.
- \*2: Clearance (d) is required over 200mm so as to open the rear door.  
In case that clearance (d) is less than clearance (b), give priority to clearance (b).

**Figure 17 Service clearances for a four-rack, two-controller system**

**Table 21 Floor load rating and required clearances for a four-rack, two-controller system**

Floor load rating (kg/m <sup>2</sup> )	Required clearance (a+b) m							
	c= -0.3	c=0	c=0.2	c=0.4	c=0.6	c=0.8	c=1.0	c=1.4
Over 700	0	0	0	0	0	0	0	0
600	0.1	0	0	0	0	0	0	0
500	0.8	0.4	0.2	0	0	0	0	0
450	1.3	0.8	0.6	0.4	0.2	0.1	0	0
400	1.9	1.4	1.1	0.9	0.7	0.5	0.3	0.1
350	2.9	2.3	1.9	1.6	1.4	1.2	0.9	0.6

Floor load rating (kg/m <sup>2</sup> )	Required clearance (a+b) m							
	c= -0.3	c=0	c=0.2	c=0.4	c=0.6	c=0.8	c=1.0	c=1.4
300	4.4	3.6	3.2	2.8	2.5	2.2	1.9	1.5
<b>Notes:</b> <ol style="list-style-type: none"> <li>1. Actual clearances for installation should be determined after consulting with the construction specialist responsible for installations in the building. Clearances can vary depending on the size/layout of the system and building conditions.</li> <li>2. When various configurations of storage systems are arranged in a row, clearance values based on the largest storage system configuration should be used.</li> <li>3. For easier maintenance operations, make clearance (c) as large as possible.</li> </ol>								

### Four-rack configuration - two controllers (left)

The following figure shows the service clearances for a four-rack, two-controller configuration, with the controllers in the left two racks.

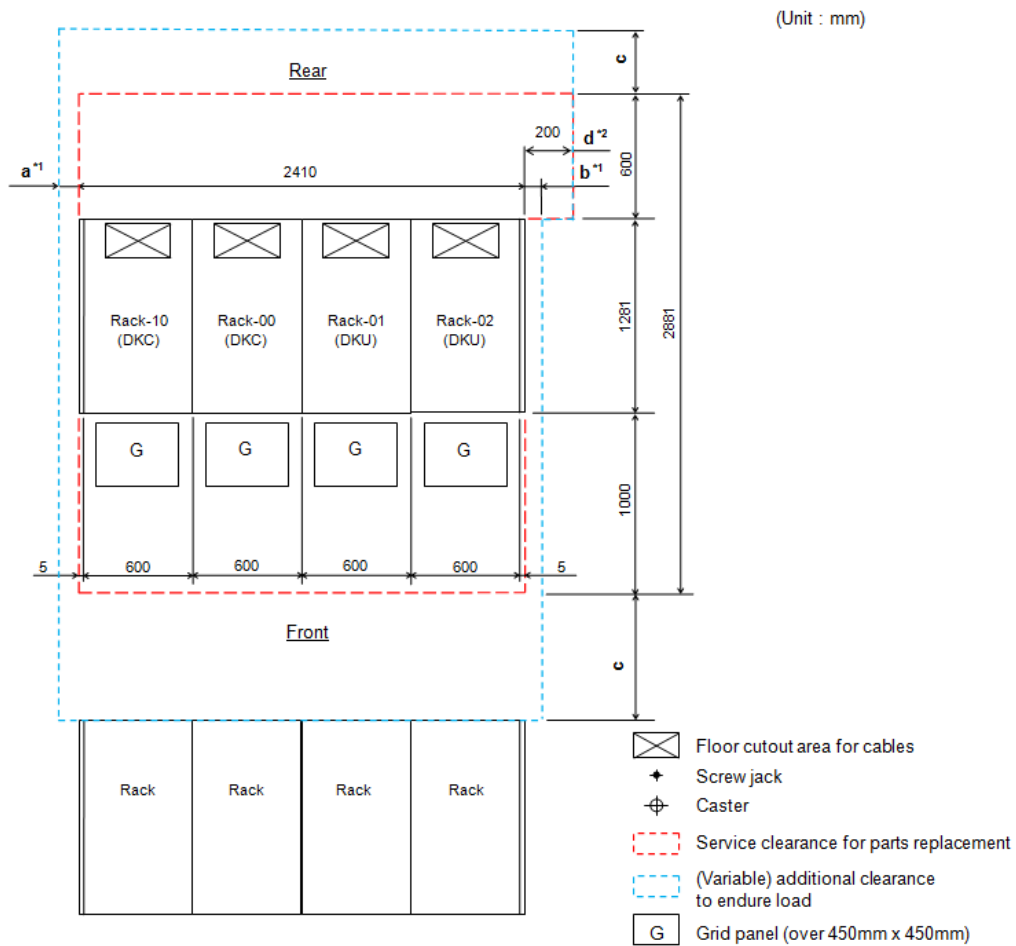

- \*1: Clearance (a+b) is based on the floor load rating and the clearance (c).  
Floor load rating and required clearances are shown in the table below.
- \*2: Clearance (d) is required over 200mm so as to open the rear door.  
In case that clearance (d) is less than clearance (b), give priority to clearance (b).

Figure 18 Service clearances for a four-rack, two-controller system

Table 22 Floor load rating and required clearances for a four-rack, two-controller system

Floor load rating (kg/m <sup>2</sup> )	Required clearance (a+b) m							
	c=-0.3	c=0	c=0.2	c=0.4	c=0.6	c=0.8	c=1.0	c=1.4
Over 700	0	0	0	0	0	0	0	0
600	0.1	0	0	0	0	0	0	0
500	0.8	0.4	0.2	0	0	0	0	0
450	1.3	0.8	0.6	0.4	0.2	0.1	0	0
400	1.9	1.4	1.1	0.9	0.7	0.5	0.3	0.1

Floor load rating (kg/m <sup>2</sup> )	Required clearance (a+b) m							
	c= -0.3	c=0	c=0.2	c=0.4	c=0.6	c=0.8	c=1.0	c=1.4
350	2.9	2.3	1.9	1.6	1.4	1.2	0.9	0.6
300	4.4	3.6	3.2	2.8	2.5	2.2	1.9	1.5

**Notes:**

1. Actual clearances for installation should be determined after consulting with the construction specialist responsible for installations in the building. Clearances can vary depending on the size/layout of the system and building conditions.
2. When various configurations of storage systems are arranged in a row, clearance values based on the largest storage system configuration should be used.
3. For easier maintenance operations, make clearance (c) as large as possible.

## Five-rack configuration

The following figure shows the service clearances for a five-rack configuration.

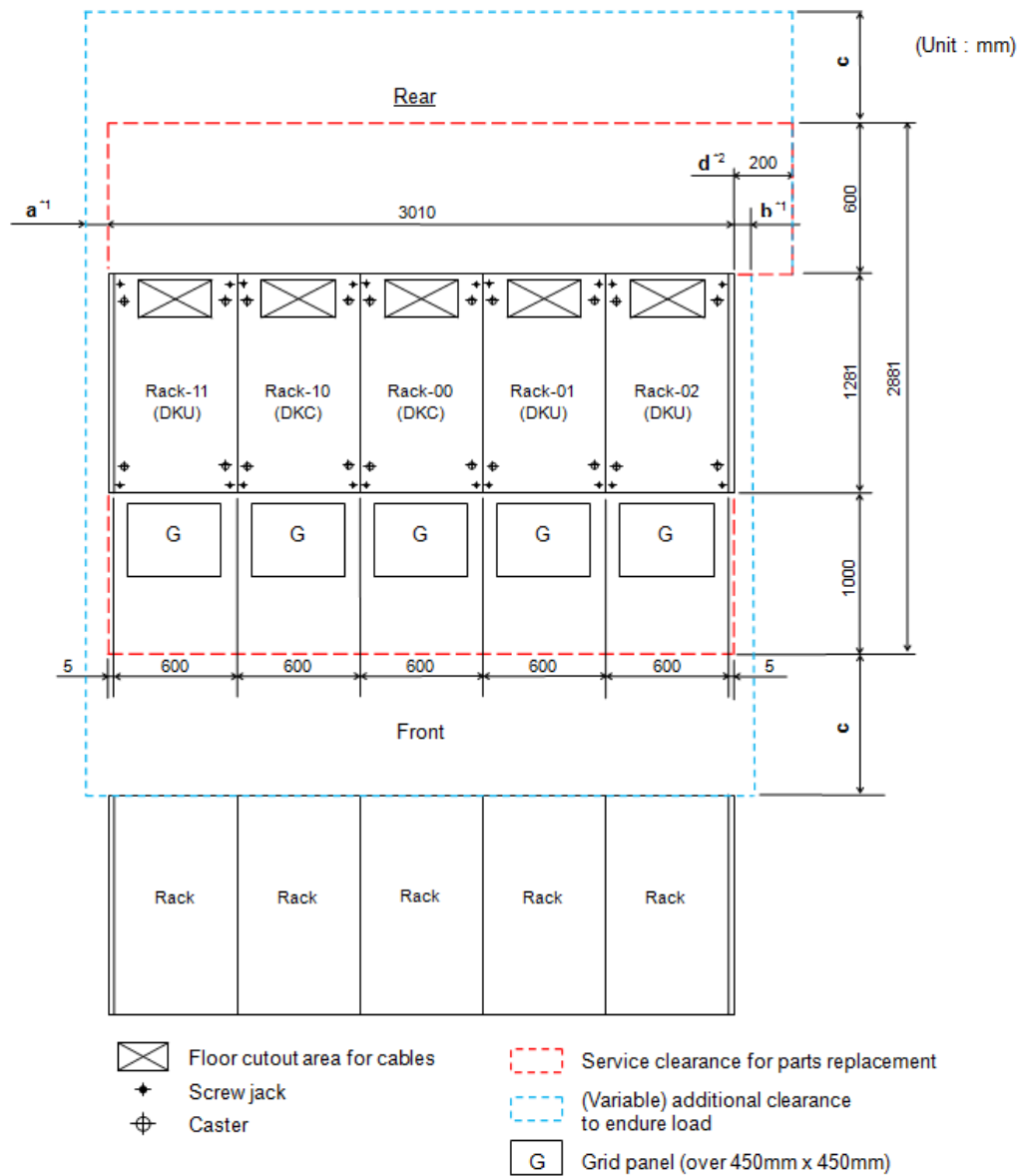

- \*1: Clearance (a+b) is based on the floor load rating and the clearance (c).  
Floor load rating and required clearances are shown in the table below.
- \*2: Clearance (d) is required over 200mm so as to open the rear door.  
In case that clearance (d) is less than clearance (b), give priority to clearance (b).

**Figure 19 Service clearances for a five-rack system**

**Table 23 Floor load rating and required clearances for a five-rack configuration**

Floor Load Rating (kg/m <sup>2</sup> )	Required Clearance (a+b) m							
	c= -0.3	c=0	c=0.2	c=0.4	c=0.6	c=0.8	c=1.0	c=1.4
Over 700	0	0	0	0	0	0	0	0
600	0	0	0	0	0	0	0	0

Floor Load Rating (kg/m <sup>2</sup> )	Required Clearance (a+b) m							
	c= -0.3	c=0	c=0.2	c=0.4	c=0.6	c=0.8	c=1.0	c=1.4
500	0.8	0.3	0.1	0	0	0	0	0
450	1.4	0.9	0.6	0.3	0.1	0	0	0
400	2.2	1.6	1.2	0.9	0.7	0.5	0.3	0
350	3.3	2.6	2.2	1.3	1.5	1.2	1.0	0.6
300	5.2	4.2	3.7	3.2	2.8	2.5	2.2	1.6

**Notes:**

1. Actual clearances for installation should be determined after consulting with the construction specialist responsible for installations in the building. Clearances can vary depending on the size/layout of the system and building conditions.
2. When various configurations of storage systems are arranged in a row, clearance values based on the largest storage system configuration should be used.
3. For easier maintenance operations, make clearance (c) as large as possible.

## Six-rack configuration

The following figure shows the service clearances for a six-rack configuration.

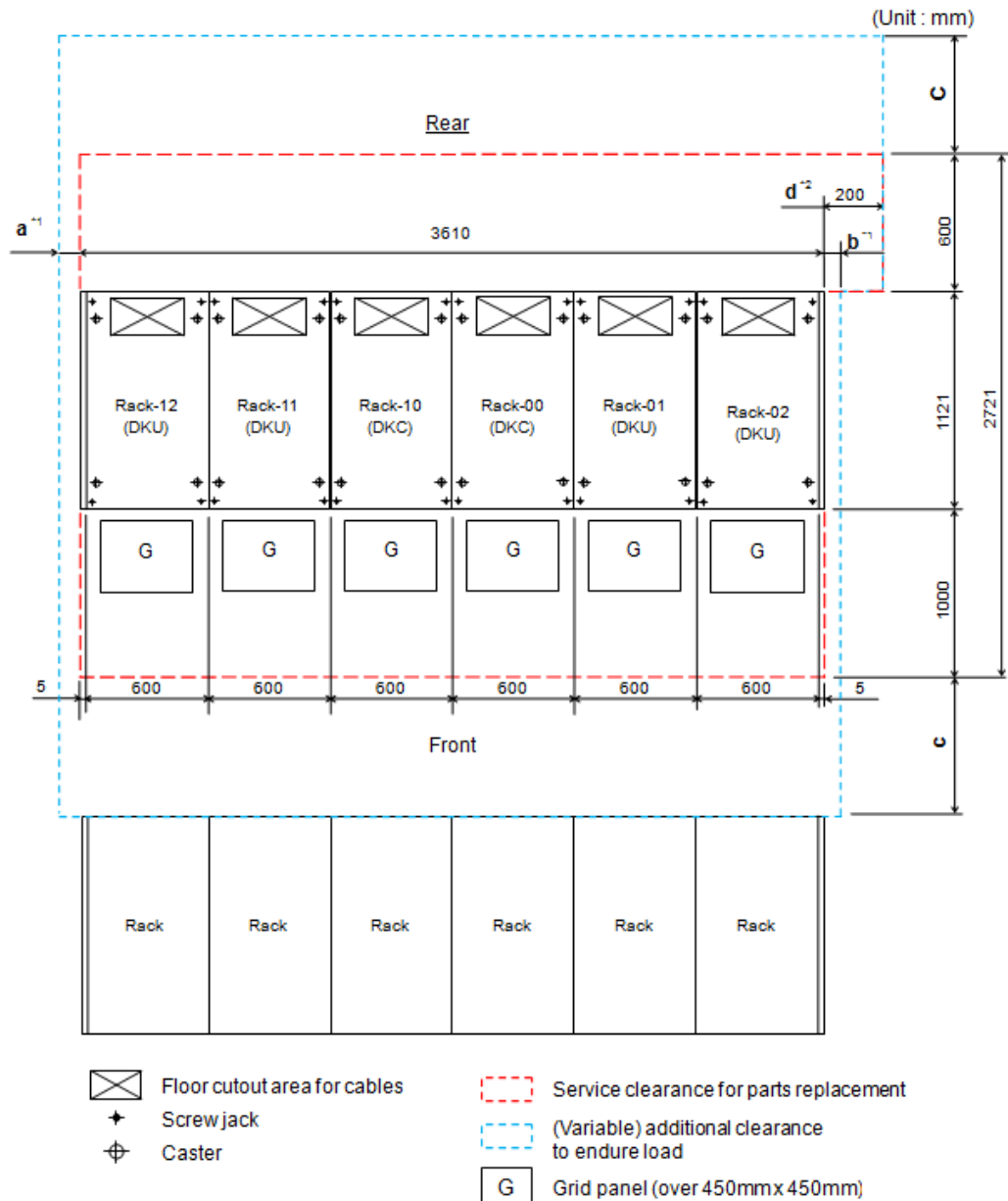

- \*1: Clearance (a+b) is based on the floor load rating and the clearance (c).  
Floor load rating and required clearances are shown in the table below.
- \*2: Clearance (d) is required over 200mm so as to open the front door.  
In case that clearance (d) is less than clearance (b), give priority to clearance (b).

**Figure 20 Service clearances for a six-rack system**

**Table 24 Floor load rating and required clearances for a six-rack configuration**

Floor Load Rating (kg/m <sup>2</sup> )	Required Clearance (a+b) m							
	c= -0.3	c=0	c=0.2	c=0.4	c=0.6	c=0.8	c=1.0	c=1.4
Over 700	0	0	0	0	0	0	0	0

Floor LoadRating (kg/m <sup>2</sup> )	Required Clearance (a+b) m							
	c= -0.3	c=0	c=0.2	c=0.4	c=0.6	c=0.8	c=1.0	c=1.4
600	0	0	0	0	0	0	0	0
500	1.0	0.4	0.1	0	0	0	0	0
450	1.7	1.1	0.7	0.4	0.2	0	0	0
400	2.6	1.9	1.5	1.2	0.9	0.6	0.3	0
350	4.0	3.1	2.6	2.2	1.8	1.5	1.2	0.7
300	6.2	5.1	4.4	3.9	3.4	3.0	2.6	2.0

Notes;

1. Actual clearances for installation should be determined after consulting with the construction specialist responsible for installations in the building. Clearances can vary depending on the size/layout of the system and building conditions.
2. When various configurations of storage systems are arranged in a row, clearance values based on the largest storage system configuration should be used.
3. For easier maintenance operations, make clearance (c) as large as possible.

## Seven-rack configuration

The following figure shows the service clearances for a seven-rack configuration.



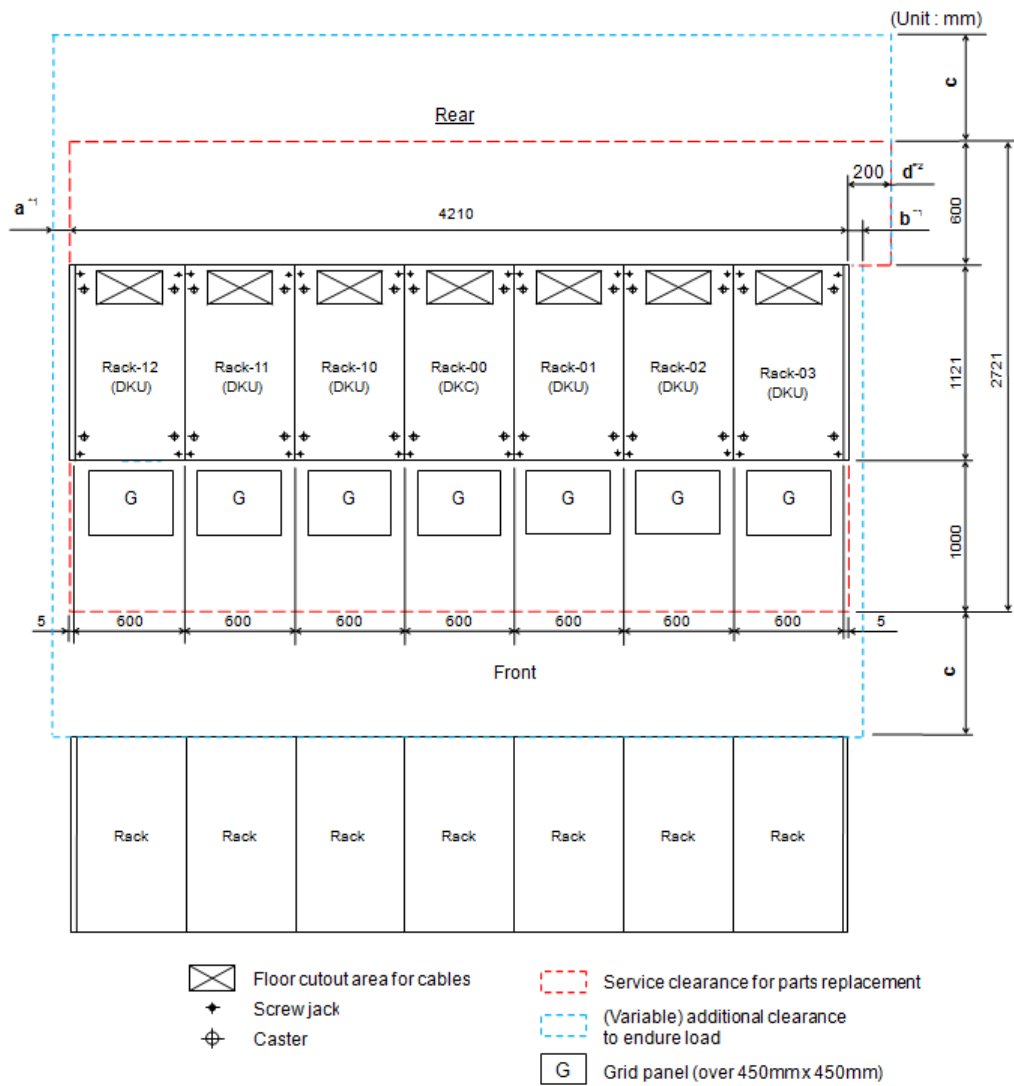

\*1: Clearance (a+b) is based on the floor load rating and the clearance (c).  
Floor load rating and required clearances are shown in the table below.

\*2: Clearance (d) is required over 200mm so as to open the rear door.  
In case that clearance (d) is less than clearance (b), give priority to clearance (b).

Figure 21 Service clearances for a seven-rack system

Table 25 Floor load rating and required clearances for a seven-rack configuration

Floor Load Rating (kg/m <sup>2</sup> )	Required Clearance (a+b) m							
	c= -0.3	c=0	c=0.2	c=0.4	c=0.6	c=0.8	c=1.0	c=1.4
Over 700	0.3	0	0	0	0	0	0	0
600	1.1	0.6	0.3	0.1	0	0	0	0
500	2.1	1.5	1.2	0.9	0.7	0.4	0.2	0
450	2.9	2.2	1.8	1.5	1.2	1.0	0.7	0.4

Floor LoadRating (kg/m <sup>2</sup> )	Required Clearance (a+b) m							
	c= -0.3	c=0	c=0.2	c=0.4	c=0.6	c=0.8	c=1.0	c=1.4
400	4.0	3,2	2.7	2.3	2.0	1.7	1.4	1.0
350	5.6	4.6	4.0	3.5	3.1	2.7	2.4	1.9
300	8.0	6.7	6.0	5.4	4.9	4.4	4.0	3.3
<p>Notes;</p> <ol style="list-style-type: none"> <li>1. Actual clearances for installation should be determined after consulting with the construction specialist responsible for installations in the building. Clearances can vary depending on the size/layout of the system and building conditions.</li> <li>2. When various configurations of storage systems are arranged in a row, clearance values based on the largest storage system configuration should be used.</li> <li>3. For easier maintenance operations, make clearance (c) as large as possible.</li> </ol>								

# Chapter 5: Cable connection guidelines

Observe the following guidelines when configuring host port connections and connecting power or data cables to VSP G1000, VSP G1500, and VSP F1500 storage systems.

## Port configurations

The following figures show the front-end director port configurations.

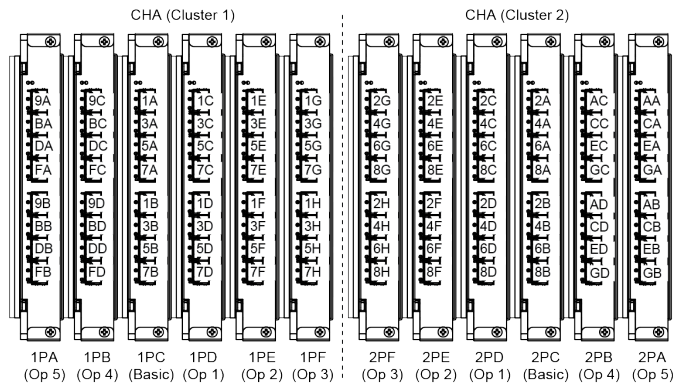

**Figure 22 Front-end director 16-port configuration**

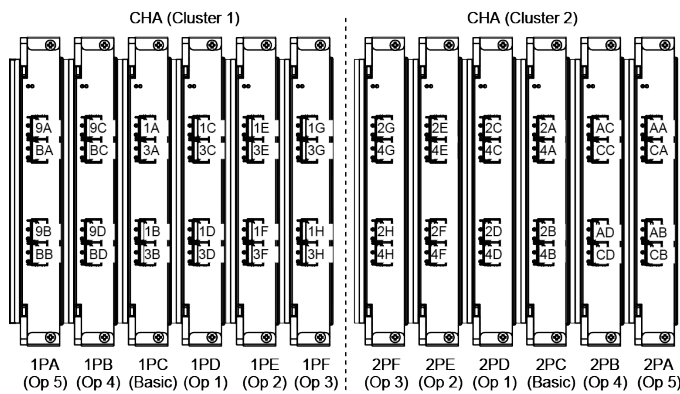

**Figure 23 Front-end director 8-port configuration**

## Power connection diagrams

The following figures show how to connect the power distribution units to the power distribution panels. When connected as shown, the system operates normally if either AC inputs fails. In the following figures, redundancy is provided through separate PDUs. These figures assume the separate power distribution units are attached to independent PDUs.

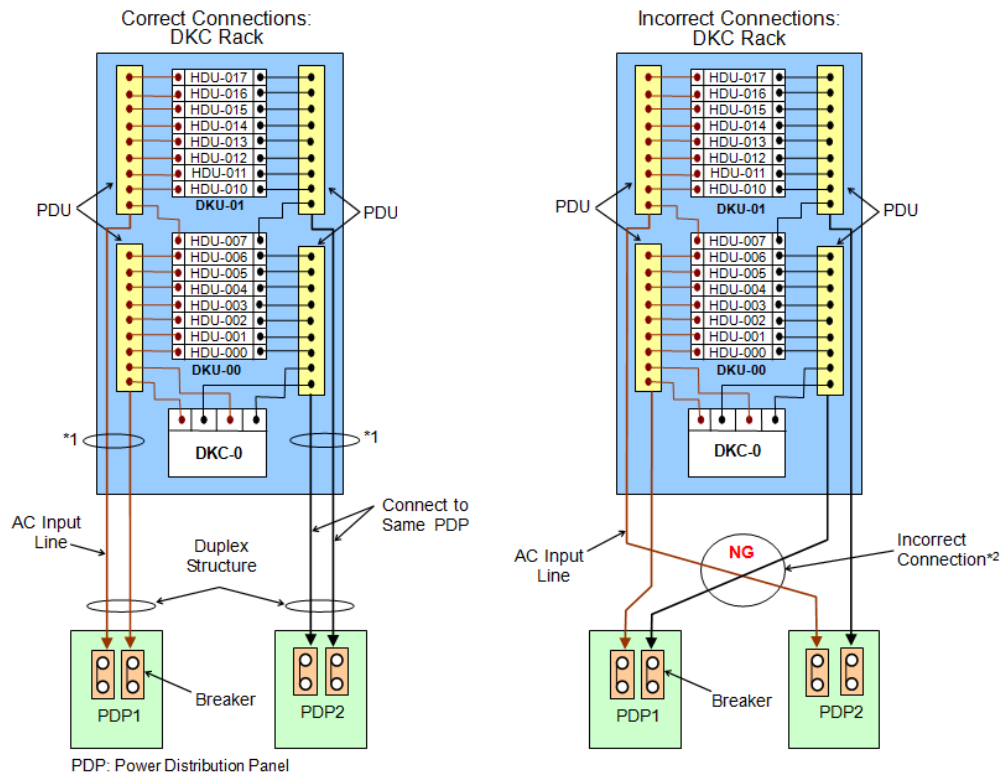

\*1: When connected correctly, two of the four PDUs can supply power to the DKC rack.

\*2: When connected incorrectly, two PDUs cannot supply power to the DKC rack, which causes a system failure.

Figure 24 Direct power connection

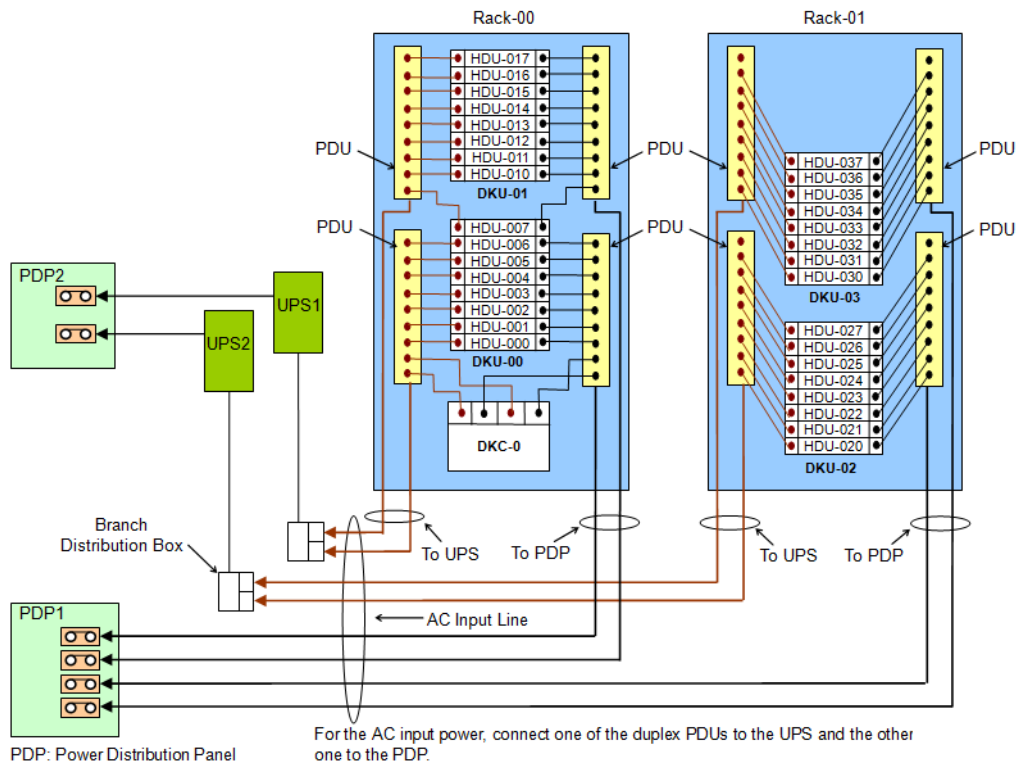

**Figure 25 Power connection via UPS**

**Caution:** When installing a system, do not cross-connect the AC cables as shown in the previous illustration. Otherwise, a system failure can occur when either AC input is interrupted.

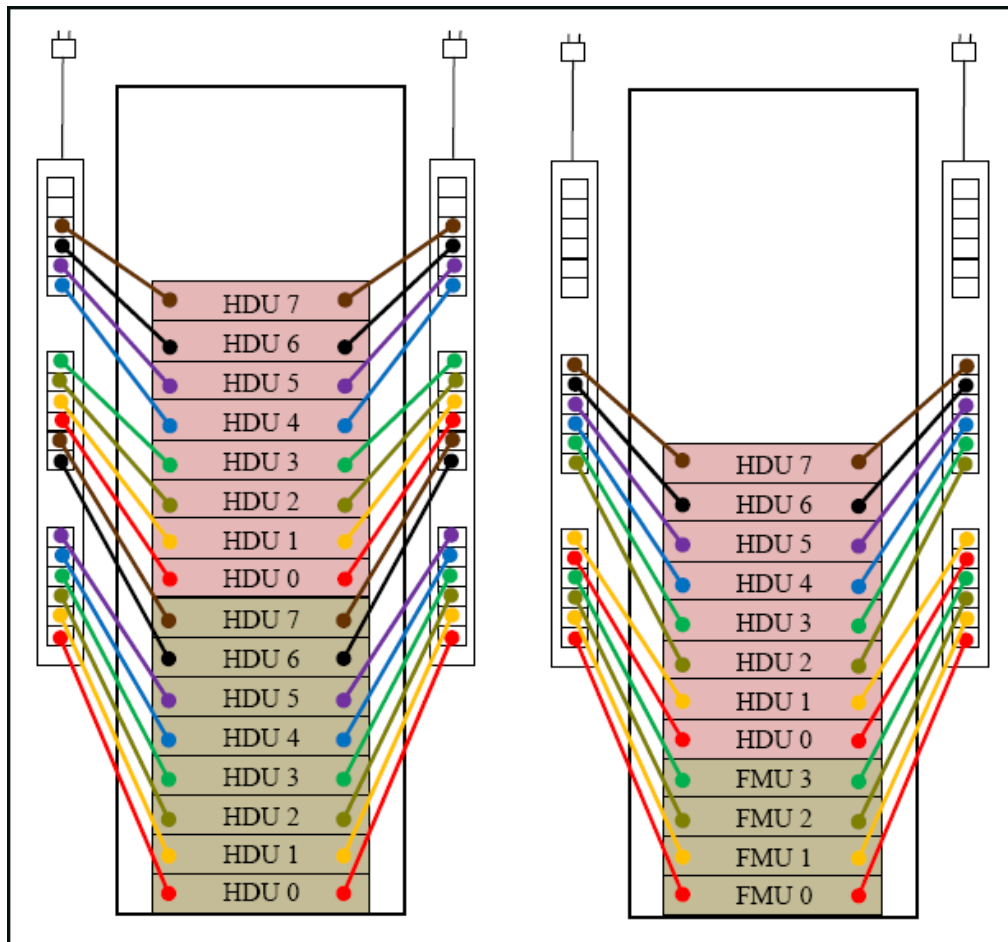

Figure 26 PDP breaker connections for the controller rack, three-phase

## UPS power connection

The following figure shows how to connect the PDUs to the PDP when an uninterruptible power supply is used.

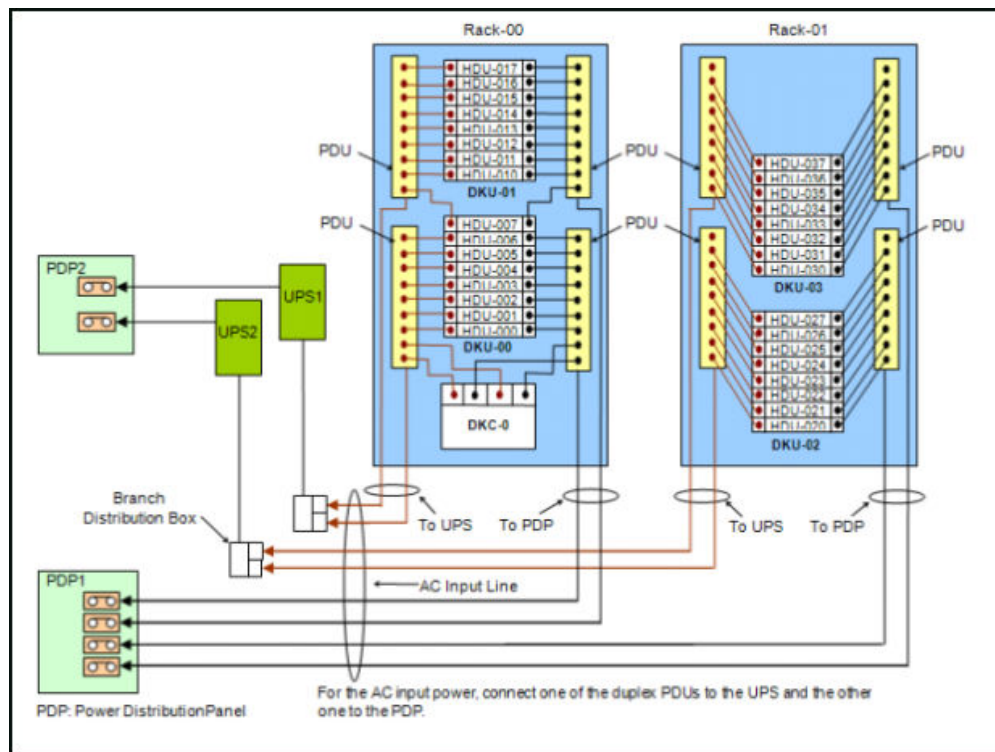
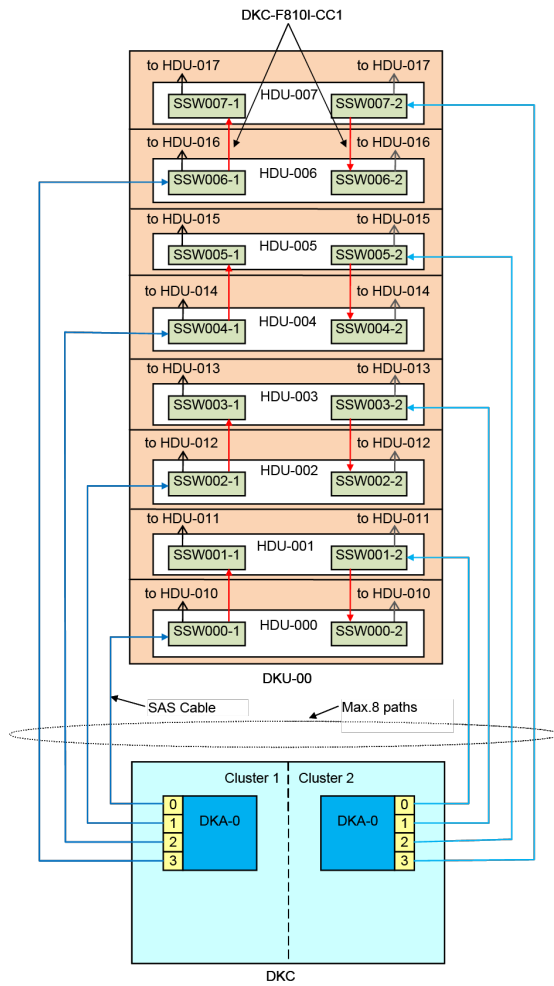

Figure 27 Breaker configurations when using a UPS

## Data connection diagrams

This section provides basic cabling diagrams for connecting ENC (data and control) cables between the control chassis and the drive chassis in the block module, and between the controller and HNAS storage in the file module.

The following illustrations show how to connect the drive chassis to the controller.



**Figure 28 SAS connection diagram of Rack-00 (SFF/LFF standard model)**



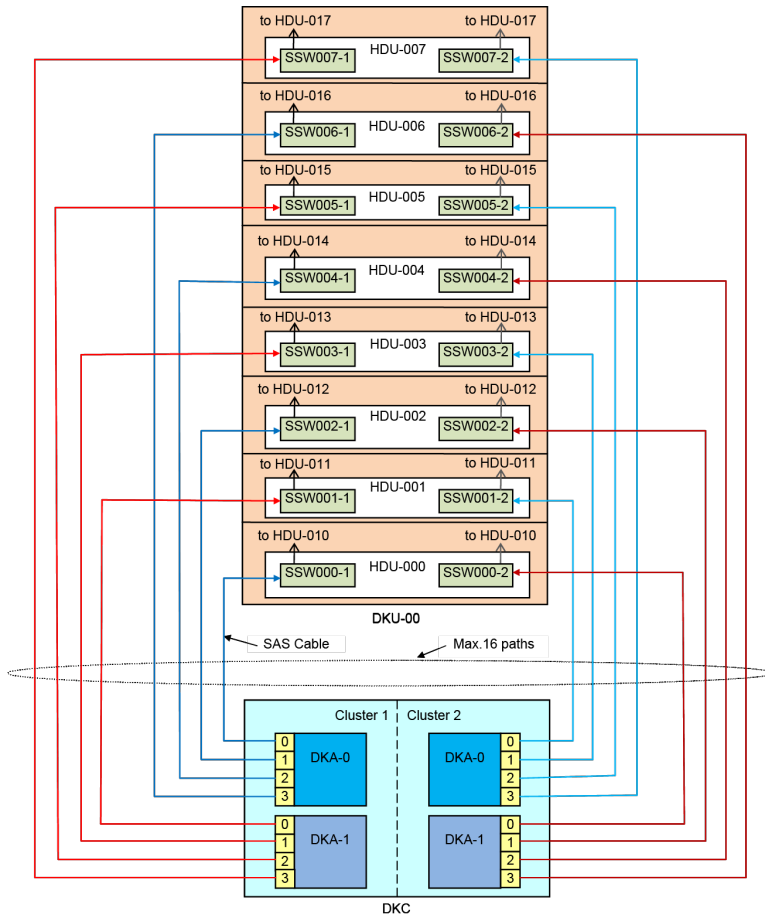

**Figure 29 SAS connection diagram of Rack-00 (SFF/LFF high-performance model)**

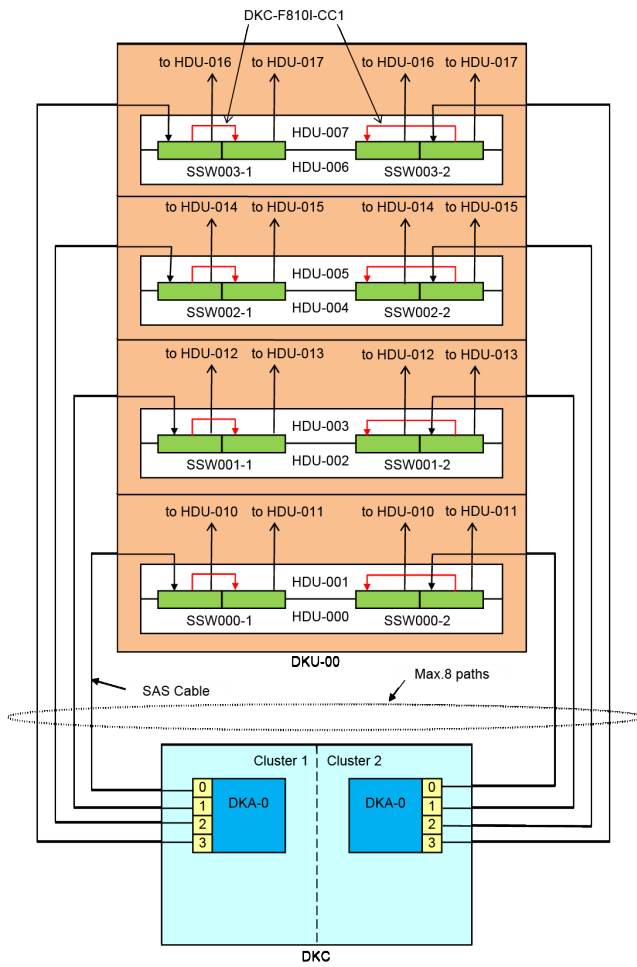

Figure 30 SAS connection diagram of Rack-00 (FBX standard model)

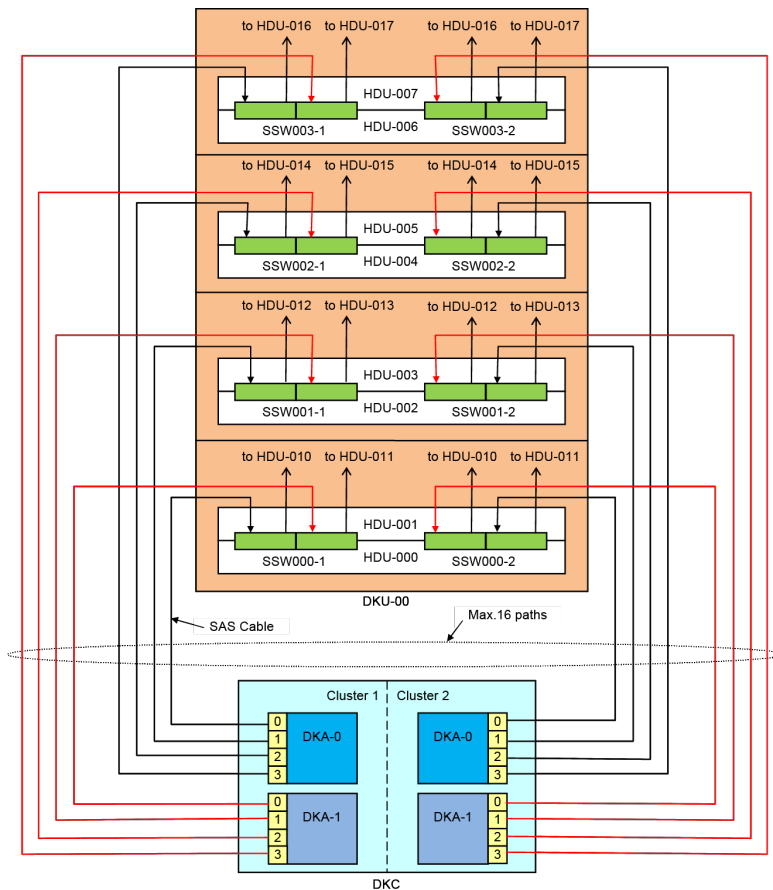
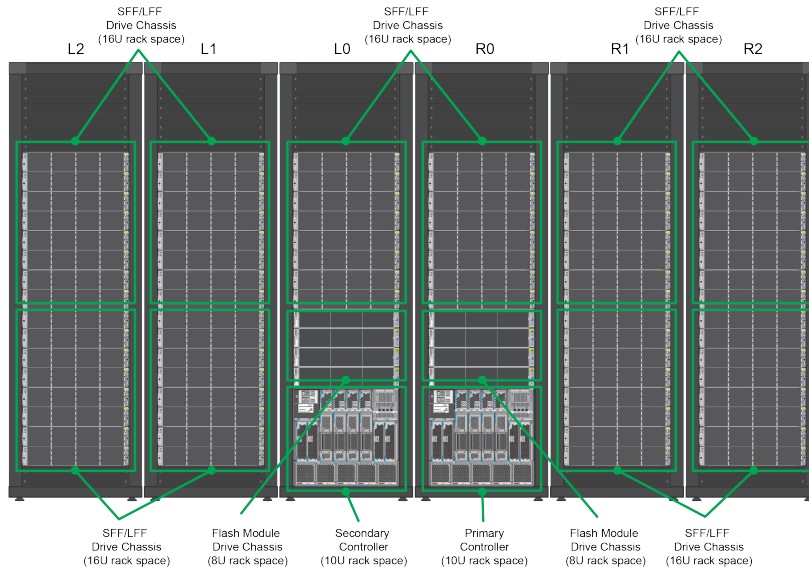

Figure 31 SAS connection diagram of Rack-00 (FBX high-performance model)

## Extended cable connections

By default, all storage systems installed in Hitachi Vantara racks are physically connected to each other. Two side panels are included to cover the sides of the outermost racks (see the following figure). To provide greater flexibility with the placement of the racks within a data center, there are multiple options for implementing separated rack configurations to meet the requirements of the customer. The following sections provide information about the available options and associated configuration rules. For more information about rack configuration and extended cabling options, contact a Hitachi Vantara representative.

The following figure shows a default rack placement.



**Figure 32 Example of a default rack placement**

### Separated controller configuration

When designing a two controller VSP G1000 or VSP G1500 system, the default system configuration includes a *primary* and *secondary* controller chassis and each controller chassis is installed in a separate rack. This specific layout is referred to as a *Twin Controller* configuration and the racks are connected to each other.

For flexibility in placing the system in a data center, the rack containing the primary controller can be separated from the rack containing the secondary controller. The cable length options to connect the two controllers are 5 meters (standard length), 30 meters, and 100 meters. To avoid single points of failure, data and power cables can be connected to the controllers in a redundant configuration. Redundant configurations require that all cables to be the same length.

The following figure shows a two controller configuration with extended cabling between the racks containing the two controllers.

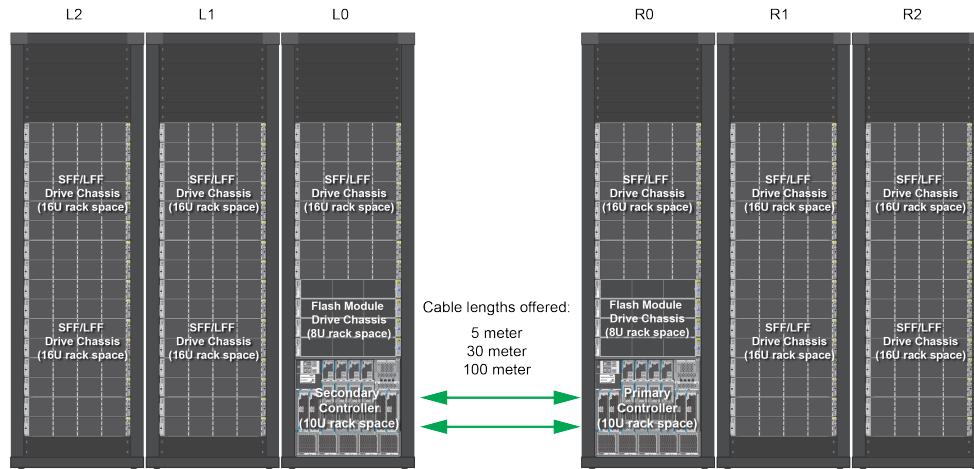
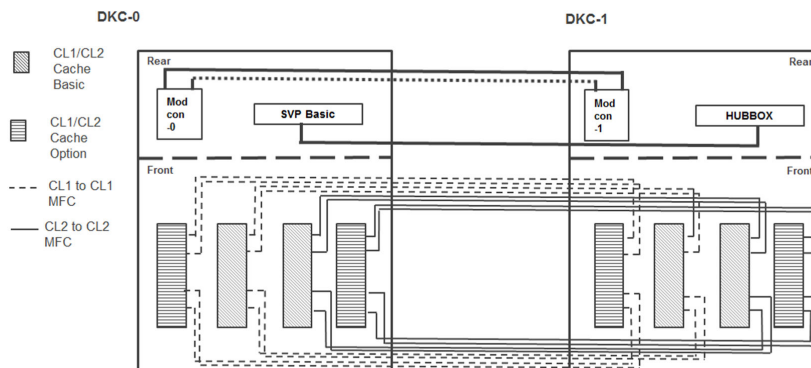

**Figure 33 Example of a separated controller configuration**

As shown in the configuration, in addition to the standard 5 meter connection, there are two optional features that can be ordered to enable the separation of the racks containing the two controllers in a dual controller storage system. Using the inter-controller connecting kit (DKC-F810I-MOD30) depends on whether the 30 or 100 meter cables are required.

The interconnect kit includes three different cable types of the required length (30 or 100 meter) and two Modcon packages (one package for each controller). Depending on whether both the basic and optional cache platform board features (cache path control adapter) are installed, an addition of eight MFC optical cables may also be required along with the cables included with the interconnecting kit. The following cables are used for interconnecting various components in the primary controller to the equivalent component in the secondary controller:

- 8 x MFC or 16 x MFC Optical Cables (light blue)
- 2 x Modcon Optical Cables (green)
- 1 x LAN cable (light grey)



When a customer adopts diverse routing of host cables within their data center for resiliency and redundancy reasons, it is possible to follow the same approach for the different cables used to separate the two controller racks. Where redundant routing is required, all of the CL1 interconnect cables along with one of the Modcon interconnect cables should be laid through one cable route and all of the CL2 interconnect cables, including the other Modcon cable, should be directed through an alternate cable route. The single LAN cable can be laid through either route direction. The only supported extended cable options are those specified by Hitachi. The intermixing of 30 meter and 100 meter cables in a single configuration is not permitted. Choosing the proper interconnection kit or cable length is determined by the longest cable route. When using extended cables between controllers, Hitachi recommends taking precautionary steps such as routing the cables through the cable trays in order to protect the cables from any accidental physical damage.

### Separation of drive-only racks

A system can also be designed to separate a rack that includes a combination of controllers and drive chassis from multiple racks containing only drive chassis.

The following figure shows a single-controller configuration with extended cabling between rack *R0* (containing the primary controller and two drive chassis) and *R1* rack (containing two drive chassis). In addition, the extended cabling between drive chassis-only *R1* rack and *R2* rack. Extending the cabling between racks in a *Twin Configuration* is also supported.

To avoid I/O latency issues, the sum of the length of all cables (controller-to-drive chassis cable and drive chassis-to-drive chassis cables) cannot exceed 125 meters.

The following example shows a configuration of a controller controlling a maximum of six drive chassis.

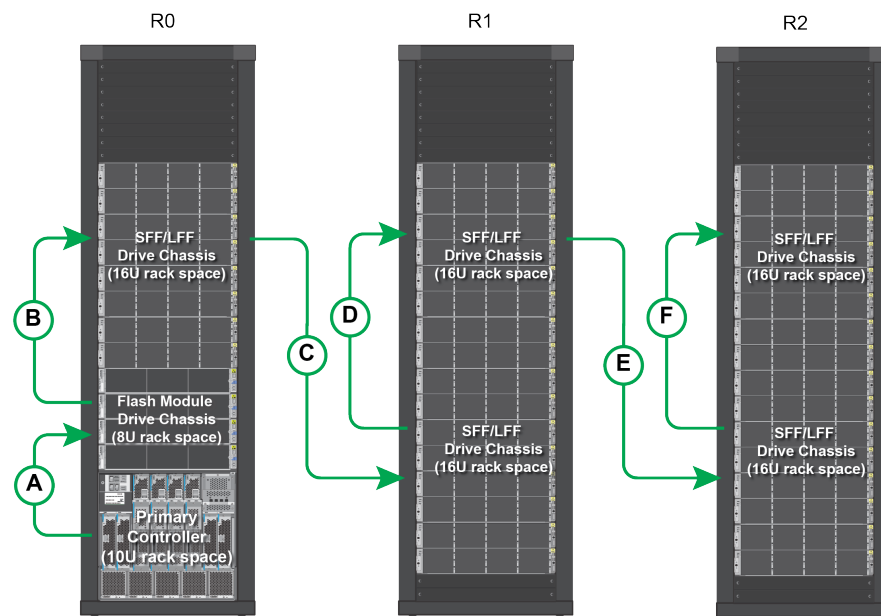

The sum of the lengths all cables (A through F) must be less than or equal to 125 meters.

**Figure 34 Example of a separation of drive-only racks**

There are three optional cable kits available to provide the separation of drive-only racks from either the control rack or adjacent drive-only rack.

Each kit contains eight optical cables in either 5, 30, or 100 meter lengths and provides enough cables to support the SAS paths from one backend module feature or pair of disk boards. The number of drive rack interconnection kits required for a specific configuration depends on various factors including the number of installed backend modules and racks being separated in the configuration.

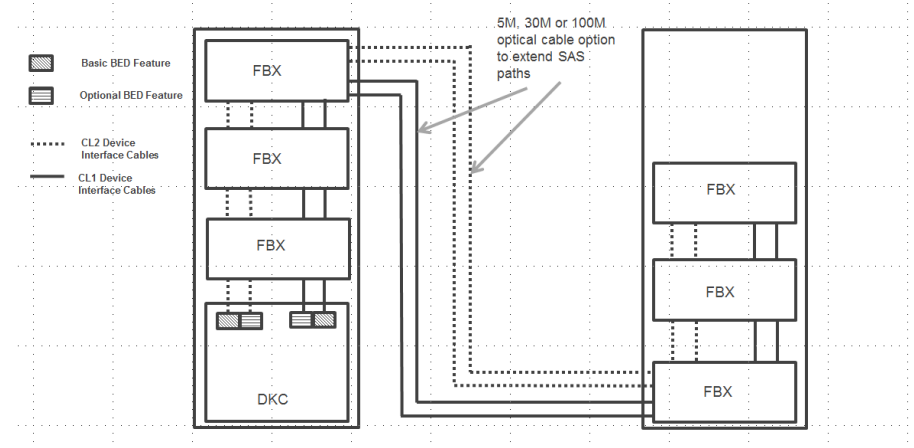

The figure illustrates a single controller installed with both the basic and optional backend modules in a high performance, all-flash configuration using FMDs. The example uses the extended cable kit to separate the controller rack from the second drive rack. In this supported configuration, only the cables in the controller interconnect kit are provided by Hitachi.

When a customer adopts diverse routing of host cables within their data center for resiliency and redundancy reasons, it is possible to follow the same approach for the cables that are used to separate the two racks. Where redundant routing is required, all of the cables extending the SAS paths from any backend modules in CL1 should be laid through one cable route and all cables extending the SAS paths from any backend modules in CL2 should be directed through an alternate route. The cables connecting any two racks must be the same length so choosing the proper cable kit is determined by the longest cable route between the two racks. When using extended cables between racks, Hitachi recommends taking precautionary steps such as routing the cables through the cable trays in order to protect the cables from any accidental physical damage.

### Separated controller and drive-only rack configuration

A separated controller and drive-only rack configuration separates the rack with the controllers from a rack containing only drive chassis. This particular configuration combines both options described in the previous two examples.

The following figure shows a *Twin controller* configuration with extended SAS optical cabling between *R0* rack (containing the primary controller) and *R1* rack (containing two drive chassis), as well as between *L0* rack (containing the secondary controller) and *L1* rack (containing two drive chassis).

Although not shown in the following figure, the configuration can include an *R2* rack directly connected to, or separated from the *R1* rack. Similarly, the configuration can include an *L2* rack directly connected to, or separated from the *L1* rack. To avoid I/O latency issues, the sum of the length of all cables (controller-to-drive chassis cable and drive chassis-to-drive chassis cables) cannot exceed 125 meters.

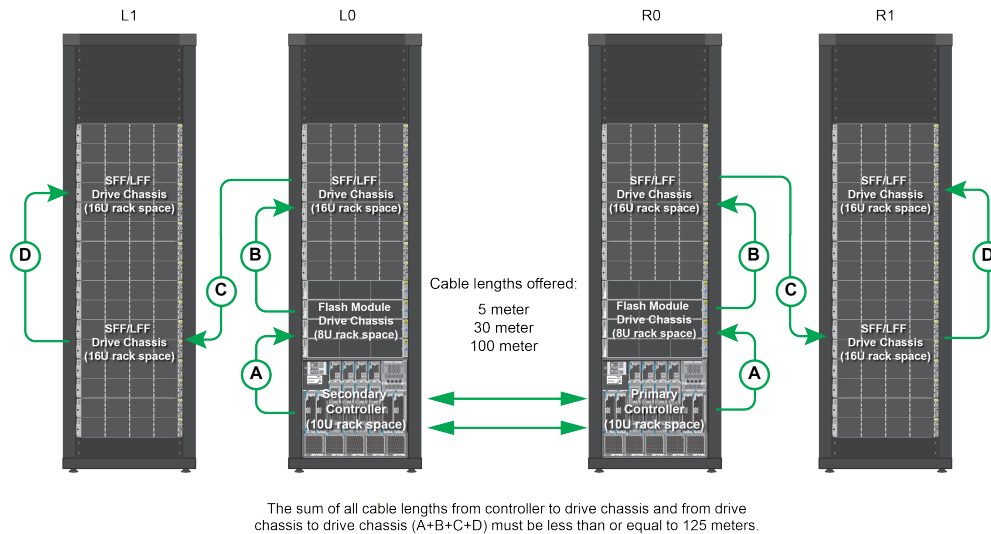

**Figure 35 Example of a separated controller and drive-only rack configuration**

### Separated racks in a dual controller configuration

A *dual controller* configuration contains two controllers installed into a single rack. The *dual controller* configuration can include up to two flash memory drive chassis in the same rack and separate racks containing only drive chassis.

The following figure shows a *dual controller* configuration with extended SAS optical cables connecting between rack *R0* (containing both primary and secondary controllers) and rack *R1* (containing two drive chassis) and rack *L0* (containing three drive chassis). To avoid any I/O latency issues the sum of the length of all cables (controller-to-drive chassis cable and drive chassis-to-drive chassis cable) cannot exceed 125 meters.



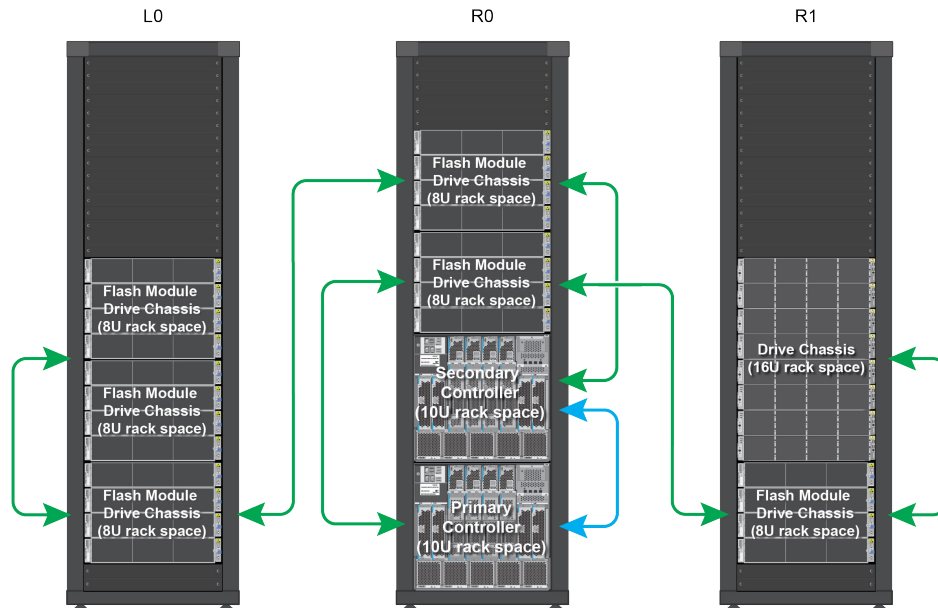

**Figure 36 Example of a separated racks in a dual controller configuration**

#### Additional guidelines

- You can implement extended cabling with a system installed in customer-supplied racks only if the racks meet HDS specifications and are approved by the HDS Customer Sales and Support (CSS) organization.
- The *high temperature mode* option can be implemented on VSP G1x00 systems using extended cabling.
- The minimum microcode requirements to support extended cabling includes:
  - VSP G1000: V02 (microcode 80-02-01-00/01), released in October 2014, must be installed to support the SAS optical cables
  - VSP G1500: SVOS 7.0 (microcode 80-05-01-00/00), released in October 2016, must be installed to support the SAS optical cables
  - To maintain proper functioning of storage system, continue to keep the storage system microcode level current to ensure code enhancements and fixes. If the storage system is using an earlier version of microcode, contact an authorized service provider for assistance with planning, ordering, and installing a more current microcode version.
- Consult a Hitachi Vantara representative for more information about system configurations and available extended cabling options.

## Chapter 6: Turning storage system power on and off

The storage system can be powered on and off using the power control panel located on the node interconnect switch during normal operating conditions or a power failure. See [#unique\\_109](#) for switch locations.

### Power control panel

The power control panel is located in the top left corner of the controller. It is covered by a 2U-high bezel that can be removed separately from the 8U bezel that covers the rest of the controller.

The following illustration shows the switches and indicators on the control panel. The following table lists the components and LED descriptions. All LEDs are shown ON to demonstrate the LED color.

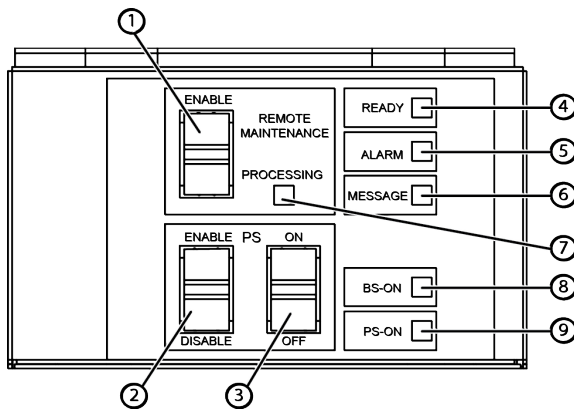

**Figure 37 Storage system power control panel**

**Table 26 Storage system power controls and status indicators**

Item	Description
1	REMOTE MAINTENANCE switch <ul style="list-style-type: none"> <li>▪ Set to ENABLE to allow remote maintenance.</li> <li>▪ Set to DISABLE to prevent remote maintenance.</li> </ul>
2	ENABLE switch: Used to enable the PS ON/PS OFF switch. See <a href="#">Power on procedures (on page 125)</a> .

Item	Description
3	POWER switch: Turn system power on or off. See <a href="#">Power on procedures (on page 125)</a> .
4	<p>READY LED: Indicates the operational status of the system</p> <ul style="list-style-type: none"> <li>▪ Off: When the channel interface is not operational.</li> <li>▪ Green: When the I/O operation on the channel interface is enabled.</li> </ul>
5	<p>ALARM LED</p> <ul style="list-style-type: none"> <li>▪ Off: When the system is off or when the system is on and operational without failures .</li> <li>▪ Red: When the SVP detects a component failure or other failure condition in the system.</li> </ul>
6	<p>MESSAGE LED</p> <ul style="list-style-type: none"> <li>▪ Off: When power is off, or when a system-generated message is not in the queue, and the SVP has not failed.</li> <li>▪ Amber: On when a system information message (SIM) is generated by either cluster and sent to Device Manager - Storage Navigator and to the users that are set up in Device Manager - Storage Navigator to receive them.</li> <li>▪ Blinking: When an SVP failure has occurred in a single SVP configuration, or if both SVPs have failed in a dual SVP configuration. Does not blink if only one SVP in a dual SVP configuration fails.</li> </ul>
7	<p>PROCESSING LED: Indicates the status of remote processing</p> <ul style="list-style-type: none"> <li>▪ Off: When power is off or when remote maintenance is not taking place.</li> <li>▪ Amber: On when remote maintenance is taking place.</li> </ul>
8	<p>BS-ON LED: Indicates the status of the AC power to the system (basic supply)</p> <ul style="list-style-type: none"> <li>▪ Off: When AC power is applied to the system from the PDUs.</li> <li>▪ Amber: On when AC power is applied to the system from the PDUs. The fans are running.</li> </ul>
9	<p>PS-ON LED: Indicates the status of the DC power to the system</p> <ul style="list-style-type: none"> <li>▪ Off: When AC power is not applied to the system and when AC power is applied to the system, and the system is in idle mode.</li> <li>▪ Green: When power is on, DC power is applied to the system, and the system is running.</li> </ul>

## System idle mode

When the storage system power cables are plugged into the PDUs and the PDU breakers are on, the storage system is in idle (basic supply only) mode. When the storage system is in idle mode:

- The amber Basic Supply (BS) LED on the control panel is on. AC power is applied to the power supplies.
- The green READY LED is off. The controller and drive chassis are not operational.
- The fans in both the controller and drive chassis are running.
- The cache backup batteries are being charged.
- The storage system consumes significantly less power than it does in operating mode. For example, a storage system that draws 100 amps while operating draws only 40 to 60 amps in idle mode, depending on the number of drives in the system. The more drives, the more power is saved. See [Table 27 Maximum idle power per chassis \(on page 124\)](#) and [#unique\\_112](#).

To put the storage system into idle mode from the OFF condition:

1. Ensure power is available to the AC input boxes and PDUs in all racks.
2. Turn on all PDU power switches and circuit breakers.

To put the storage system into idle mode from a power on condition, perform the steps in [Power off procedures \(on page 125\)](#).

To shut down the storage system, perform the power off procedures, and then turn off all PDU circuit breakers.



**Warning:** Verify the storage system is turned off normally and in idle mode before turning off the PDU circuit breakers. Otherwise, turning off the PDU circuit breakers can leave the storage system in an abnormal condition.

**Table 27 Maximum idle power per chassis**

Chassis	Maximum idle power (VA)
Controller Chassis 0 or 1	500
SFF Drive Chassis	1,120
LFF Drive Chassis	720
FMD Drive Chassis	1,280

## Normal power on/off procedures

This section provides general information about turning on and turning off the power to the storage system. If further assistance is required, contact customer support.

## Power on procedures

### Before you begin

- Confirm the storage system is in idle mode. See [System idle mode \(on page 124\)](#).



**Note:** The control panel includes a safety feature to prevent the storage system power from being turned on or off accidentally. The PS ON/OFF switch does not work unless the ENABLE switch is moved to and held in ENABLE while the power switch is moved to ON or OFF.

Perform the procedure to turn on the storage system. If applicable, see [Power control panel \(on page 122\)](#).

### Procedure

1. On the control panel, check the amber BS LED and make sure it is lit. It indicates that the storage system is in idle mode.
2. In the PS area on the control panel, move the ENABLE switch to the ENABLE position and hold it there. While holding the switch in the ENABLE position, move the PS ON/OFF switch to ON. Then release both switches.
3. Wait for the storage system to complete its power-on self-test and start processes. Depending on the storage system configuration, this can take several minutes.  
The storage system does not go to the READY state until the cache backup batteries are charged to at least 50%. The process can take 90 minutes if the batteries are completely discharged. The storage system generates a SIM that provides the status of the battery charge. See [Cache backup batteries \(on page 129\)](#) for information about the batteries.
4. When the system self-test is complete and all components are operating normally, the green READY LED turns ON and the storage system is ready for use.  
If the ALARM LED is also ON, or if the READY LED is not ON after 20 minutes, contact customer support for assistance.

## Power off procedures

### Before you begin

- Confirm all maintenance and software-specific shutdown procedures have been completed.
- Verify all I/O activity to the storage system has stopped. You can vary paths offline and shut down the attached hosts.
- Follow this procedure exactly when powering off the storage system.



**Caution:** Except in an emergency, do not turn off the PDU breakers before turning off the power to the system. The system reacts as a power failure occurred and uses the cache backup batteries to keep the cache active until the data in the cache is transferred to the cache backup flash memory. When the cache backup batteries discharge power, the power-on time can be prolonged by the amount of charge remaining in the batteries. Fully discharged batteries take 90 minutes to charge.



**Note:** The control panel includes a safety feature to prevent the storage system power from being turned on or off accidentally. The PS power ON/OFF switch does not work unless the ENABLE switch is moved to and held in ENABLE while the power switch is moved to ON or OFF.

### Procedure

1. In the PS area on the control panel, move the ENABLE switch to the ENABLED and hold it there. While holding the switch in ENABLED, move the PS ON/OFF switch to OFF. Then release both switches.
2. Wait for the storage system to complete its shutdown routines. Depending on the storage system configuration and certain MODE settings, you can wait 20 minutes for the storage system to copy data from the cache to the cache flash drives and for the disk drives to spin down.  
If the READY and PS LEDs do not turn OFF after 20 minutes, contact customer support for assistance.

## Emergency power off/on procedures

The following describes how to shut off the system during an emergency situation and turning on power to the storage system after an emergency shutdown.

### Turning off power to the storage system during an emergency

The storage system does not have an emergency power off switch. Use the following procedure to turn off the system during an emergency.



**Note:** When turning off the storage system, first turn off the PDUs connecting to the controllers and then turn off the PDUs connecting to the drive trays.

### Procedure

1. Open the back doors of both racks that contain control units.
2. Turn off the circuit breakers in the following order:
  - a. Turn off the circuit breakers in both lower PDUs in both racks.
  - b. Turn off the circuit breakers in both upper PDUs in both racks with control units.
3. Open the back doors of all racks containing only drive units and, in any order, turn off the circuit breakers to all the PDUs.

## Turning on power to the storage system after an emergency shutdown

To turn the power on to the storage system after an emergency shutdown, use the following instructions.



**Note:** When turning on the storage system, first turn on the PDUs connecting to the drive trays and then turn on the PDUs connecting to the controllers.

### Procedure

1. In all system racks, turn on the circuit breakers in the PDUs supplying electrical power to the drive units.
2. In both controller racks, turn on the circuit breakers in the PDUs supplying electrical power to the controllers.
3. Turn on power to the system. For more information, see [Normal power On/Off procedures \(on page 124\)](#).

## Chapter 7: VSP G1x00 and F1x00 batteries

The batteries temporarily provide the storage system with power to maintain its caching operation during a power failure event. The following information describes the battery life expectancy, battery operation, and cache backup process. Also, some specific guidelines are provided for storing the system during an extended period of time non-operation.

### Battery backup operations

The storage system is designed to retain data and configuration information when the power fails. The battery system can provide sufficient power with fully charged batteries to completely back up all data in the cache if two consecutive power failures occur. If the batteries do not contain enough charge to provide sufficient time to back up the cache when a power failure occurs, the cache operates in write-through mode and writes directly to the drives to prevent slow data throughput via the cache. When the battery charge is 50% or more, the cache write through mode is turned off and the system operates normally.

If a power failure occurs and continues for up to 20 milliseconds, the storage system continues normal operation. If the power failure exceeds 20 milliseconds, the storage system uses power from the batteries to keep the cache active while the system copies the storage system configuration and cached data to the cache flash memory in the cache backup modules. The process continues up to 32 minutes. The cache flash drives do not require power to retain the data.

The following illustration shows the timing if a power failure occurs.

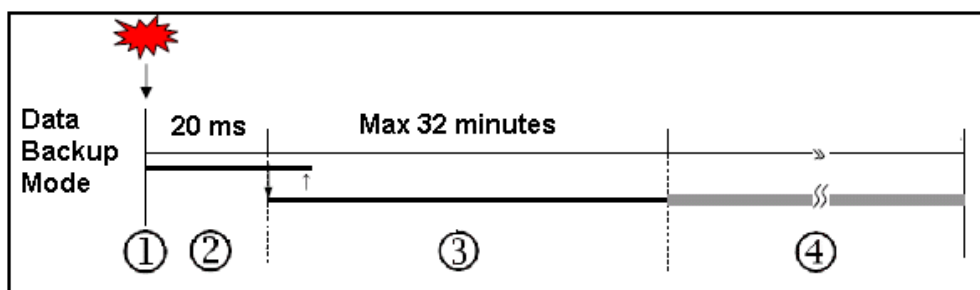

Item	Description
1	Power failure occurs.



Item	Description
2	The storage system continues to operate for 20 milliseconds and detects the power failure.
3	The cache memory data and storage system configuration are backed up to the cache flash memory in the cache backup assemblies. If power is restored during the backup, the backup stops unless the backup battery capacities are used less than 50%. In case, the system operates in write-through mode until the batteries are charged enough for a full backup.
4	Data is stored in the cache flash memory until power is restored, and then it is written to the drives.

## Cache backup batteries

If a power failure occurs, nickel-hydrate batteries keep the cache memory active while the entire storage system configuration and data in the cache are copied to the flash memory in the cache backup modules. The batteries are located in the cache backup modules. They are fully charged at the distribution center where the storage system is assembled and tested. During shipment, the batteries are disconnected automatically to prevent any discharging during shipping and storage until the system is installed. During installation, they are reconnected. The following figure provides an overview of the cache backup battery.



**Note:** The storage system generates a SIM when the cache backup batteries are not connected.

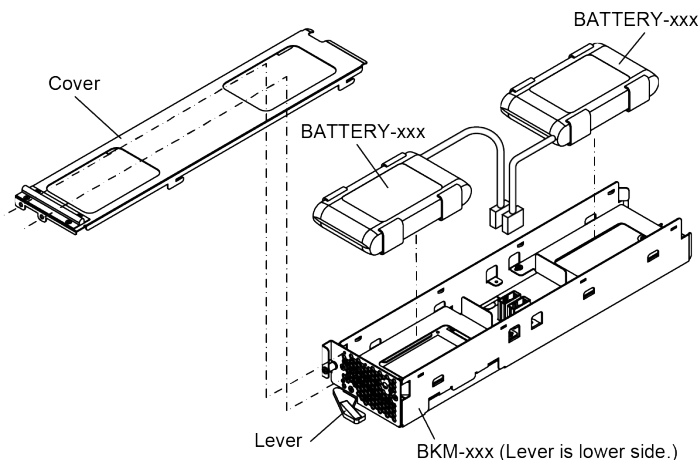

## Battery life

The batteries have a lifespan of three years and hold a charge for a specific amount time when disconnected. When the batteries are connected and power is on, the batteries are continuously charging. The process occurs during both normal system operation and while the system is in idle mode.

When the batteries are connected and the power is off, the batteries slowly discharge its power. The batteries have a charge of less than 50% after two weeks without power. When the batteries are fully discharged, the batteries must be connected to power for three hours to fully recharge.



**Note:** The storage system generates a SIM when the cache backup batteries are not charged to at least 50%. The LEDs on the front panel of the cache backup kits also show the status of the batteries.

## Storing the system

While connected, the cache backup batteries completely discharge in two to three weeks without power. If you are not using the storage system for two weeks or more, contact customer support to move the batteries to an active storage system, or set the storage system to idle mode for at least 3 hours once every two weeks.

If you store the system for more than two weeks without disconnecting the cache backup batteries, the batteries need to charge for at least 90 minutes when you restart the system before the cache can be protected. To prevent the batteries from discharging during long-term storage, contact technical support and request a disconnection of the battery jumpers on the cache boards.

---

## Chapter 8: Troubleshooting the storage system

Maintaining a properly functioning storage system includes having the proper knowledge of troubleshooting issues when they occur and access to help with more technically complicated matters.

### Getting help

If you continue experience technical difficulties after troubleshooting the storage system, contact Hitachi Vantara Support at [https://support.hds.com/en\\_us/contact-us.html](https://support.hds.com/en_us/contact-us.html).

### Solving problems

The following table lists possible error conditions and recommends actions to resolve each condition for the storage system.

If you cannot resolve an error condition, contact your Hitachi Vantara representative or contact customer support for assistance.

**Table 28 Troubleshooting errors**

Error condition	Recommended action
Error message displayed	Determine the type of error (refer to the SIM codes section). If possible, fix the cause of the error. If you cannot correct the error condition, contact customer support for assistance.
General power failure	Turn off all PDU switches and breakers. After the facility power is fully restored, turn on the switches and breakers and power on the system.  See <a href="#">Turning storage system power on and off (on page 122)</a> for instructions about turning on the power to the storage system. If necessary, contact customer support for assistance.
Fence message is displayed on the console	Determine whether there is a failed storage path. If a failed storage path occurred, toggle the RESTART switch and retry the operation. If the fence message displays again, contact customer support for assistance.

Error condition	Recommended action
READY LED does not go on, or there is no power supplied	Contact customer support for assistance.  WARNING: Do not open the storage system control frame/controller or touch any controls.
ALARM LED is on	If there is a temperature problem in the area, turn the power off to the storage system, lower the room temperature to the specified operating range, and then turn on the power to the storage system. If necessary, contact customer support for assistance with turning on the power to the storage system. If the area temperature is not the cause of the alarm, contact customer support for assistance.

## Service information messages

The storage systems generate service information messages (SIM) to identify normal operations. For example, TrueCopy pair status change, as well as service requirements and errors or failures. For assistance with SIMs, contact customer support.

SIMs can be generated by the front-end directors, back-end directors, and the SVP. All SIMs generated by the storage system are stored on the SVP for use by Hitachi Vantara personnel, displayed by the Device Manager - Storage Navigator software, and reported over SNMP to the open-systems host. The SIM display on Device Manager - Storage Navigator enables users to remotely view the SIMs reported by the attached storage systems. Each time a SIM is generated, the amber Message LED on the control panel turns on. The Hitachi Remote Ops also reports all SIMs to the support center.

SIMs are classified in four severity levels: service, moderate, serious, and acute. The service and moderate SIMs (lowest severity) do not require immediate attention and are addressed during routine maintenance. The serious and acute SIMs (highest severity) are reported to the host system once every eight hours.



**Note:** If a serious-level or high-level SIM is reported, contact the support center immediately to ensure the problem is being addressed.

The following figure illustrates a typical 32-byte SIM from the storage system. The SIMs are displayed by reference code (RC) and severity. The six-digit RC comprises bytes 22, 23, and 13, identifies the possible error and determines the severity. The SIM type, located in byte 28, indicates which component experienced the error.

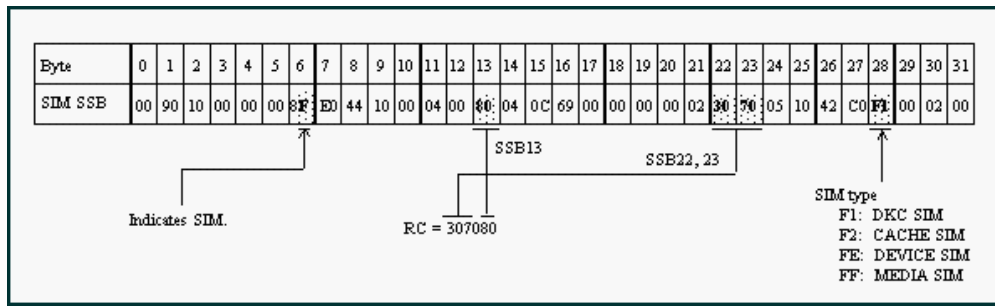

Figure 38 Service information message

## Appendix A: Storage system specifications

The following table lists the technical specifications of the VSP F1500, VSP G1500, and VSP G1000 storage systems.



**Note:** The current and power specifications of the storage system in the following tables were measured in a controlled environment. To calculate the power and current draw, and heat output of a specific system, see [Component power consumption, heat output, and airflow \(on page 151\)](#) or use the weight and power calculator at the following URL: <http://www.hds.com/go/weight-and-power-calculator/>.

If you need assistance using this tool, contact Hitachi Vantara Support at [https://support.hds.com/en\\_us/contact-us.html](https://support.hds.com/en_us/contact-us.html).

**Table 29 VSP F1500 system specifications**

Item		Specification	
System	Number of flash modules drives (FMD)	Minimum	4
		Maximum	576
	Maximum number of flash drives (SSD)	384 (Standard performance configuration) <sup>6</sup>	

Item			Specification	
			2,304 (High-performance configuration) <sup>6</sup>	
	RAID level		RAID 6/RAID 5 /RAID 1	
	RAID group configuration	RAID 6	6D+2P, 14D+2P	
		RAID 5	3D+1P, 7D+1P <sup>6</sup>	
		RAID 1	2D+2D, 4D+4D	
	Maximum number of spare drives		96 <sup>1</sup>	
	Maximum number of volumes		65,280	
	Maximum storage system capacity (physical capacity)		8,106 TB (using 14 TB FMD)	34,671 TB (using 15 TB SSD)
Internal path	Architecture		Hierarchical Star Net	
	Maximum bandwidth	Data path	768 GB/s	
		Control path	128 GB/s	
Memory	Cache memory capacity		32 GB to 2,048 GB	
	Cache flash memory capacity		256 GB to 2,048 GB	
Device interface	Controller/drive chassis interface		SAS/Dual Port	
	Data transfer rate		Maximum 6 Gb/s	
	Maximum number of drive per SAS interface (Under the FMD standard model)		72	
	Maximum number of disk adapters		4	
Channel interface	Support channel type	Mainframe	2/4/8 Gb/s Fibre Channel: 16MS8/16ML8 4/8/16 Gb/s Fibre Channel: 16MS16/16ML16	
		Open systems	2/4/8 Gb/s Fibre Channel Short Wavelength <sup>2</sup> : 16FC8 4/8/16 Gb/s Fibre Channel Short Wavelength <sup>3</sup> : 8FC16/16FC16 10 Gb/s iSCSI/FCoE Short Wavelength: 16FE10/8IS10	

Item			Specification
	Data transfer rate	Mainframe Fibre Channel	200/400/800/1600 MB/s
		Fibre Channel	200/400/800/1600 MB/s
		iSCSI/FCoE	10 Gb/s
	Maximum number of channel adapters		12
Power	AC Input	Single phase	60Hz : 200 V to 240 V 50Hz : 200 V to 240 V
Acoustic Level <sup>4</sup>	Operating	CBXE/CBXF	58dB (24°C or less), 60dB (32°C), 70dB (40°C)
		SBXC/FBX	61dB (24°C or less), 64dB (32°C), 70dB (40°C)
	Standby <sup>5</sup>	CBXE/CBXF	58dB (24°C or less), 60dB (32°C), 70dB (40°C)
		SBXC/FBX	61dB (24°C or less), 64dB (32°C), 70dB (40°C)
Dimension	W x D x H (mm)	Single rack	610 x 1,115 x 2,006
		Six racks	3,610 x 1,115 x 2,006
Non-stop maintenance	Control PCB		Support
	Cache memory module		Support
	Cache flash memory		Support
	Power supply, fan		Support
	Microcode		Support
	Drive (SSD, FMD)		Support

**Notes:**

<sup>1</sup> Available as spare or data disks.

<sup>2</sup> The port can be changed to long wavelength by replacing the SFP transceiver of the fibre port on the CHB to the DKC-F810I-1PL8.

<sup>3</sup> The port can be changed to long wavelength by replacing the SFP transceiver of the fibre port on the CHB to the DKC-F810I-1PL16.

<sup>4</sup> Measurement Condition: The point 1 m far from floor and surface of the product.



Item	Specification
<sup>5</sup> Even if storage system is in a power-off state, the cooling fan continues to rotate in a standby mode. <sup>6</sup> For VSP F1500 with FMDs installed, a minimum of 8 FMDs (min. capacity of 49 TB) are required for this specific configuration. <sup>7</sup> Does not include the spare drive.	

**Table 30 VSP G1x00 System Specifications**

Item		Specification	
System	Number of disk drives (HDD)	Minimum	4 (disk-in model) / 0 (diskless model)
		Maximum	2,304 (SFF HDD) / 1,152 (LFF HDD)
	Maximum number of flash drives (SSD)		384 (Standard performance configuration) <sup>6</sup> 2,304 (High-performance configuration) <sup>6</sup>
	Maximum number of flash module drives (FMD)		576
	RAID level		RAID 6 / RAID 5 / RAID 1
	RAID group configuration	RAID 6	6D+2P, 14D+2P
		RAID 5	3D+1P, 7D+1P
		RAID 1	2D+2D, 4D+4D
	Maximum number of spare drives		96 <sup>1</sup>
	Maximum number of volumes		65,280
	Maximum storage system capacity (physical capacity)		5,312 TB (using 2.4 TB, SFF HDD) 6,767 TB (using 6 TB, LFF HDD) 34,671 TB (using 15 TB SSD)

Item			Specification
			8,106 TB (using 14 TB FMD)
Internal path	Architecture		Hierarchical Star Net
	Maximum bandwidth	Data path	768 GB/s
		Control path	128 GB/s
Memory	Cache memory capacity		32 GB to 2,048 GB
	Cache flash memory capacity		256 GB to 2,048 GB
Device interface	Controller/drive chassis interface		SAS/Dual Port
	Data transfer rate		Maximum 6 Gb/s
	Maximum number of drives per SAS interface (Under the SFF HDD standard model)		288
	Maximum number of disk adapters		4
Channel interface	Support channel type	Mainframe	2/4/8 Gb/s Fibre Channel: 16MS8/16ML8  4/8/16 Gb/s Fibre Channel: 16MS16/16ML16
		Open systems	2/4/8 Gb/s Fibre Channel Short Wavelength <sup>2</sup> : 16FC8  4/8/16 Gb/s Fibre Channel Short Wavelength <sup>3</sup> : 8FC16/16FC16  10 Gb/s iSCSI/FCoE Short Wavelength: 16FE10/8IS10
	Data transfer rate	Mainframe Fibre Channel	200/400/800/1600 MB/s
		Fibre Channel	200/400/800/1600 MB/s
		iSCSI/FCoE	10 Gb/s
	Maximum number of channel adapters		12
	Power	AC Input	Single phase

Item			Specification
Acoustic Level <sup>4</sup>	Operating	CBXA/CBXAC/CBXB/CBXE/CBXF	58dB (24°C or less), 60dB (32°C), 70dB (40°C)
		SBX/SBXC/UBX/UBXC/FBX	61dB (24°C or less), 64dB (32°C), 70dB (40°C) <sup>7</sup>
	Standby <sup>5</sup>	CBXA/CBXAC/CBXB/CBXE/CBXF	58dB (24°C or less), 60dB (32°C), 70dB (40°C)
		SBX/SBXC/UBX/UBXC/FBX	61dB (24°C or less), 64dB (32°C), 70dB (40°C) <sup>7</sup>
Dimension	W x D x H (mm)	Single rack	610 x 1,115 x 2,006
		Six racks	3,610 x 1,115 x 2,006
Non-stop maintenance	Control PCB		Support
	Cache memory module		Support
	Cache flash memory		Support
	Power supply, fan		Support
	Microcode		Support
	Drive (HDD, SSD, FMD)		Support
<p><b>Notes:</b></p> <p><sup>1</sup> Available as spare drive or data disks.</p> <p><sup>2</sup> The port can be changed to long wavelength by replacing the SFP transceiver of the fibre port on the CHB to the DKC-F810I-1PL8.</p> <p><sup>3</sup> The port can be changed to long wavelength by replacing the SFP transceiver of the fibre port on the CHB to the DKC-F810I-1PL16.</p> <p><sup>4</sup> Measurement Condition: The point 1 m far from floor and surface of the product.</p> <p><sup>5</sup> Even if storage system is in a power-off state, the cooling fan continues to spin in a standby mode.</p> <p><sup>6</sup> Does not include the spare drive.</p> <p><sup>7</sup> The DKC-F810I-1R6FM/3R2FM and DKC-F710I-1R6FM/3R2FM cannot be used at 40°C.</p>			

**Table 31 Drive specifications and guidelines**

Type	Size (inches) <sup>1</sup>	Capacity	Speed (RPM)	Transfer rate (Gbps)
HDD (SAS)	2.5	300 GB, 600 GB	15,000	-
	2.5	600 GB, 900 GB, 1.2 TB, 1.8 TB, 2.4 TB	10,000	-
	3.5	4.0 TB, 6.0 TB <sup>6</sup>	7,200	-
		600 GB	10,000	-
SSD	2.5	400 GB, 800 GB, 960 GB, 1.9 TB, 3.8, 7.6 TB, 15 TB	-	6
	3.5	400 GB	-	6
Flash Module (MLC/TLC)	-	1.75 TB, 3.5 TB, 7 TB, 14 TB	-	6
<b>Drive installation guidelines</b>				
<ul style="list-style-type: none"> <li>▪ A minimum of 4 drives must be installed for VSP G1x00. For VSP F1500, a minimum of 8 drives must be installed.</li> <li>▪ Drives must be added in groups of 4, 8, or 16 when creating RAID groups, unless they are spare drives.</li> </ul>				

Type	Size (inches) <sup>1</sup>	Capacity	Speed (RPM)	Transfer rate (Gbps)
<ul style="list-style-type: none"> <li>▪ Use the same generation drive type and capacity size when configuring RAID setting.</li> <li>▪ Add or replace a drive with another drive of the same generation. <ul style="list-style-type: none"> <li>▪ The spare drives associated with an array group consisting of first generation Flash Module Drives (FMD) must also be a first generation FMD. The spare drives must have the same or larger capacity as the FMD drives in the array group.</li> <li>▪ The spare drives associated with an array group consisting of Flash Module Drive (FMD) DC2 drives must also be an FMD DC2 of the same generation. The spare drives must have the same or larger capacity as the FMD DC2 drives in the array groups.</li> </ul> </li> </ul> <p>Follow the listed examples:</p> <ul style="list-style-type: none"> <li>• Array group consisting of 1.6 TB FMD requires the same generation 1.6 TB FMD drive as a spare.</li> <li>• Array group consisting of 3.2 TB FMD requires the same generation 3.2 TB FMD drive as a spare.</li> <li>• Array group consisting of 1.6 TB FMD DC2 requires the same generation 1.6 TB FMD DC2 drive as a spare.</li> <li>• Array group consisting of 3.2 TB FMD DC2 requires the same generation 3.2 TB FMD DC2 drive as a spare.</li> <li>• Array group consisting of 6.4 TB FMD DC2 requires the same generation 6.4 TB FMD DC2 drive as a spare.</li> </ul>				
<b>Maximum number of drives</b>				
Drive type (inches)	Drive chassis	Max per drive chassis	Max per 2-controller system	
HDD, 2.5	SFF	192	2,304	
HDD, 3.5	LFF	96	1,152	
FMD, 5.25 <sup>3</sup>	FMD	48	576	
SSD, 2.5	SFF	192 (Standard performance configuration) <sup>4</sup> 1,152 (High-performance configuration) <sup>4</sup>	384 (Standard performance configuration) <sup>4</sup> 2,304 (High-performance configuration) <sup>4</sup>	
Spare drives <sup>5</sup>	-	48	96	
<b>Notes:</b>				
1. The LFF drive chassis uses 3.5-inch drives. The SFF drive chassis uses 2.5-inch drives.				

Type	Size (inches) <sup>1</sup>	Capacity	Speed (RPM)	Transfer rate (Gbps)
<p><b>2.</b> SFF SSD drives can be mounted in one SFF drive chassis or distributed among all of the SFF drive chassis in the storage system.</p> <p><b>3.</b> Guidelines for operating with flash module drives in high temperature mode:</p> <ul style="list-style-type: none"> <li>▪ Do not enable high temperature mode if the system contains FMDs from an earlier generation (prior to Hitachi Accelerated Flash FMD DC2 drives). The early generation FMDs cannot operate in high temperature mode. Only enable high temperature mode with Hitachi Accelerated Flash FMD DC2 drives.</li> <li>▪ Do not enable high temperature mode if the system contains a mixture of early and current generation FMDs.</li> </ul> <p><b>4.</b> Recommended maximum number.</p> <p><b>5.</b> Recommended number of spare drives: 1 spare HDD per set of 32 HDDs and 1 spare SSD per set of 32 SSDs.</p> <p><b>6.</b> Recommended number of spare drives for 6-TB LFF drive only: one spare drive per set of 16.</p>				

## Appendix B: Mechanical specifications

The following tables list the dimensions and weight specifications of the VSP G1000, VSP G1500, and VSP F1500 storage systems in a single-rack, single-controller, and dual-controller configurations.

**Table 32 Dimension specifications**

Dimension	Single rack	Single controller (3 racks)	Dual controller (6 racks)
Width (inches/mm)	21.6/600	70.9/1,800	141.7/3,600
Depth (inches/mm)	47.2/1,200	47.2/1,200	47.2/1,200
Height (inches/mm)	79.1/2,010	79.1/2,010	79.1/2,010

**Table 33 Weight specifications**

System weight	Single rack	Single controller (3 racks)	Dual controller (6 racks)
(lb/kg)	Diskless 1 controller: 638/290 2 controllers: 983/446	-	-
Maximum (lb/kg)	1,301/591 384 SFF drives	3,214/1,461 1,152 SFF drives	6,418/2,917 2,304 SFF drives
Maximum (lb/kg)	1,268/578 (includes 192 LFF drives)	3,181/1,446 (includes 576 LFF drives)	6,362/2,892 (includes 1,152 LFF drives)

## Appendix C: Electrical specifications

The VSP G1000, VSP G1500, and VSP F1500 storage system PDUs support both single-phase or three-phase AC power. The system components use single phase 220 VAC.

**Table 34 Input power specifications**

Item	Input Power to PDUs	Input Current <sup>1</sup>	Steady Current <sup>2</sup>	Leakage Current	Inrush Current		
					1st (0-p)	2nd (0-p)	1st (0-p) Time (-25%)
DKC PS	Single phase,	7.18A	3.59A	0.28mA	20A	15A	80ms
UBX PS	2 pole + ground	2.07A	1.04A	1.75mA	25A	20A	150ms
SBX PS	AC 200 V -8% min to	2.61A	1.31A	1.75mA	25A	20A	150ms
FBX PS	AC 240 V +6% max <sup>3</sup>	2.83A	1.42A	2.8mA	20A	10A	80ms

**Notes:**

1. The maximum current in case AC input is not a redundant configuration (in case of 184 V [200 V - 8%]).
2. The maximum current in case AC input is a redundant configuration (in case of 184 V [200 V - 8%]).
3. 110/120 VAC system is not supported.

### Power Supply Locations

The following figure shows the locations of the power supplies in a controller chassis, LFF/SFF drive chassis, and FMD chassis.



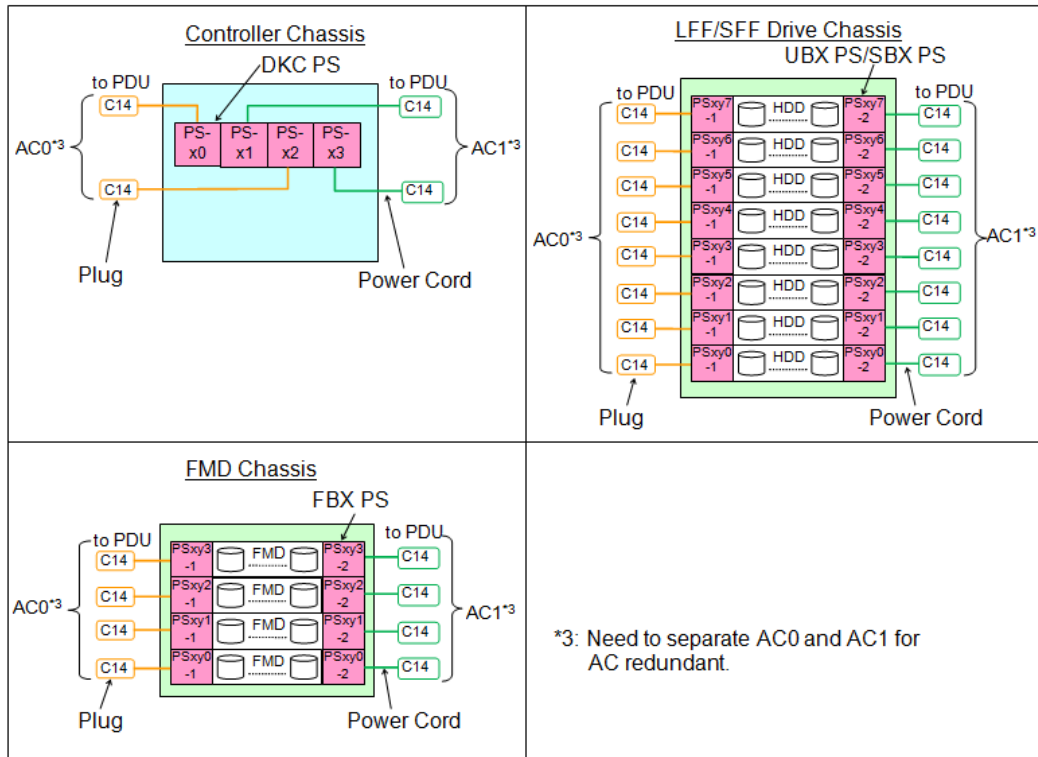

**Note:** Depending on the configuration, the storage system can draw considerably less power than the rating of the PDU plugs. Use the weight and power calculator to determine the power draw for a specific system. See [Component power consumption, heat output, and airflow \(on page 151\)](#) or use the Weight and Power Calculator to calculate the power draw, current draw, and heat output of a specific system at the following URL:

<http://www.hds.com/go/weight-and-power-calculator/>.

**Table 35 PDU plugs, circuit breakers, and receptacles**

Phase	Location	PDU Plug	Operating / Max Voltage Rating	Max Current Rating	No. of CB per PDU	Breaker Rating
Single <sup>2</sup>	Americas PDU-121 112F10	NEMA L6 30P twistlock 2 pole, 3 wire A + B + gnd	208 VAC	30A	2 UL489	16A, 20 A trip
	EMEA, APAC A3CR-12 3294-51	IEC 309, blue 2 pole, 3 wire A + B + gnd	230 VAC / 250 VAC	32A	2 UL489	16A, 20 A trip

Phase	Location	PDU Plug	Operating / Max Voltage Rating	Max Current Rating	No. of CB per PDU	Breaker Rating
Three <sup>3</sup>	Americas PDU-32C 13800F10	NEMA L15 30P 3 pole, 4 wire A + B + C + gnd	208 VAC / 240 VAC	30A per phase	3 UL489	15A 2 pole
	EMEA, APAC A3CK-24 3694-50	IEC 309, red 4 pole, 5 wire A + B + C + Neut + gnd	400 VAC	32A per phase	3 UL489	16A 2 pole

**Notes:**

<sup>1</sup>The numbers in this table were provided by the PDU manufacturer's specifications. For information about PDUs, see [Power distribution units for Hitachi Universal V2 Rack \(on page 158\)](#).

<sup>2</sup>Americas: Single phase, 30 Amp PDU, (12) IEC C13. EMEA/APAC: Single phase, 32 Amp PDU, (12) IEC C13; (2) IEC C19 .

<sup>3</sup>Americas: Method three phase, 30 Amp PDU, (24) IEC C13; (6) IEC C19. EMEA/APAC: Minkels three phase, 32 Amp PDU, (24) IEC C13; (6) IEC C19.

## Appendix D: Environmental specifications

The following table lists the specifications of the environmental conditions for the VSP G1000, VSP G1500, and VSP F1500 storage systems. The differences between standard and high temperature modes are indicated when applicable.

**Table 36 Environmental specifications**

Item	Condition		
	Operating <sup>1</sup>	Not operating <sup>2</sup>	Shipping and storage <sup>3</sup>
Standard temperature mode (°C)	16 to 32	-10 to 43 -10 to 35 <sup>10</sup>	-25 to 60
High temperature mode (°C)	16 to 40	-10 to 43	-25 to 60
Relative Humidity (%) <sup>4</sup>	20 to 80	8 to 90	5 to 95
Max. Wet Bulb (°C)	26	27	29
Temperature deviation per hour (°C)	10	10	20
Gaseous contaminants <sup>11</sup>	G1 classification levels		
Altitude Standard temperature mode	-200 ft./-60 m to 9842 ft./3,000 m		-
Altitude High temperature mode	-200 ft./-60 m to 4920 ft./1,500 m		-
Vibration <sup>5</sup>	5 Hz to 10 Hz: 0.25 mm 10 Hz to 300 Hz: 0.49 m/s <sup>2</sup>	5 Hz to 10 Hz: 2.5 mm 10 Hz to 70 Hz: 4.9 m/s <sup>2</sup> 70 Hz to 99 Hz: 0.05 mm 99 Hz to 300 Hz: 9.8 m/s <sup>2</sup>	Sine Vibration: 4.9 m/s <sup>2</sup> , 5 min., at the resonant frequency with the highest displacement found between 3 Hz and 100 Hz <sup>6</sup>

Item	Condition		
	Operating <sup>1</sup>	Not operating <sup>2</sup>	Shipping and storage <sup>3</sup>
			Random Vibration: 0.147 m/s <sup>2,3</sup> , 30 min, 5 Hz to 100Hz <sup>7</sup>
Earthquake resistance (m/s <sup>2</sup> )	up to 2.5 <sup>12</sup>	-	-
Shock	-	78.4m/s <sup>2</sup> (8.0G) 15ms	Horizontal: Incline Impact 1.22 m/s <sup>8</sup> Vertical: Rotational Edge 0.15m <sup>9</sup>
Dust	Less than 0.15 mg per cubic meter of air	-	-
Noise Level (Recommended)	90 dB or less <sup>13</sup>	-	-

**Notes:**

1. Environmental specification for operation should be met before the storage system is powered on. Maximum temperature of 90°F/32°C at air system air inlet should be strictly met.
2. Unless otherwise specified, the non-operating condition includes both packing and unpacking conditions.
3. The system and components are packed in factory packing for shipping and storing.
4. No condensation in and around the drives should be observed under any conditions.
5. Vibration specifications are applied to all three axes.
6. See ASTM D999-01, Standard Test Methods for Vibration Testing of Shipping Containers.
7. See ASTM D4728-01 Standard Test Methods for Random Vibration Testing of Shipping Containers.
8. See ASTM D5277-92 Standard Test Methods for Performing Programmed Horizontal Impacts Using an Inclined Impact Tester.
9. See ASTM D6055-96 Standard Test Methods for Mechanical Handling of Unitized Loads and Large Shipping Cases and Crates.
10. Applies only when flash module drives are installed.
11. See ANSI/ISA-71.04-2013 Environmental Conditions for Process Measurement and Control Systems: Airborne Contaminants.
12. Time is 5 seconds or less in case of the testing with device resonance point (6 to 7Hz).
13. Fire suppression systems and acoustic noise:

Item	Condition		
	Operating <sup>1</sup>	Not operating <sup>2</sup>	Shipping and storage <sup>3</sup>
<p>Some data center inert gas fire suppression systems when activated release gas from pressurized cylinders that moves through the pipes at very high velocity. The gas exits through multiple nozzles in the data center. The release through the nozzles could generate high-level acoustic noise. Similarly, pneumatic sirens could also generate high-level acoustic noise. These acoustic noises may cause vibrations to the hard disk drives in the storage systems resulting in I/O errors, performance degradation in and to some extent damage to the hard disk drives. Hard disk drives (HDD) noise level tolerance may vary among different models, designs, capacities and manufactures. The acoustic noise level of 90 dB or less in the operating environment table represents the current operating environment guidelines in which Hitachi storage systems are designed and manufactured for reliable operation when placed 2 meters from the source of the noise.</p> <p>Hitachi does not test storage systems and data drives (data drives includes HDDs, SSDs, and FMDs) drives for compatibility with fire suppression systems and pneumatic sirens. Hitachi also does not provide recommendations or claim compatibility with any fire suppression systems and pneumatic sirens. The customer is responsible to follow their local or national regulations.</p> <p>To prevent unnecessary I/O error or damages to the hard disk drives in the storage systems, Hitachi recommends the following options:</p> <ul style="list-style-type: none"> <li>Install noise-reducing baffles to mitigate the noise to the hard disk drives in the storage systems.</li> <li>Consult the fire suppression system manufacturers on noise reduction nozzles to reduce the acoustic noise to protect the hard disk drives in the storage systems.</li> <li>Locate the storage system as far as possible from noise sources such as emergency sirens.</li> <li>If it can be safely done without risk of personal injury, shut down the storage systems to avoid data loss and damages to the hard disk drives in the storage systems.</li> </ul> <p>Damage to hard disk drives from fire suppression systems or pneumatic sirens will void the hard disk drive warranty.</p>			

The following table lists the maximum acoustic emission values [loudness in dB(A)] for the VSP G1000, VSP G1500, and VSP F1500 storage systems in standard and high temperature modes.

**Table 37 Acoustic emission levels**

Item	Controller chassis		
	Temperature (°C)	Fan speed (RPM)	Noise level (dB)
Standard temperature mode	16 to 25	4200	57.4
	25 to 32	4700	59.5

Item	Controller chassis		
	Temperature (°C)	Fan speed (RPM)	Noise level (dB)
High temperature mode (°C)	32 to 40	7400	69.3

## Appendix E: Component power consumption, heat output, and airflow

The following table provides power consumption, heat output, and airflow specifications of the individual VSP G1000, VSP G1500, and VSP F1500 system components.

Component	Component model number	Weight (lb/kg)	Power consumption (VA)	Heat output	Airflow (m <sup>3</sup> /min)
Primary controller	DKC-810I-CBXA	312/142	508 <sup>1</sup>	483 <sup>1</sup>	16.7 (32°C)
	DKC-810I-CBXAC <sup>4</sup>				25.9 (40°C)
	DKC-810I-CBXE <sup>4</sup>				
Secondary controller	DKC-F810I-CBXB	308/140	435 <sup>1</sup>	413 <sup>1</sup>	16.7 (32°C)
	DKC-F810I-CBXF				25.9 (40°C)
SFF drive chassis	DKC-F810I-SBX	315/143	674 <sup>1</sup>	640 <sup>1</sup>	9.4 (32°C)
	DKC-F810I-SBXC <sup>4</sup>				11.4 (40°C)
LFF drive chassis	DKC-F810I-UBX	299/136	674 <sup>1</sup>	640 <sup>1</sup>	6.2 (32°C)
	DKC-F810I-UBXC <sup>4</sup>				8.3 (40°C)
FMD drive chassis	DKC-F810I-FBX	169/77	640 <sup>1</sup>	600 <sup>1</sup>	8.4
Service processor	DKC-F810I-SVP	8.8/4.0	79	75	0.54
	DKC-F810I-SVPC <sup>4</sup>				

Component	Component model number	Weight (lb/kg)	Power consumption (VA)	Heat output	Airflow (m <sup>3</sup> /min)
	DKC-F810I-SVP10				
Hub	DKC-F810I-HUB	5.1/2.3	11	Included in controller chassis specs	
Virtual storage director pair (processor blades)	DKC-F810I-MP	2.7	179		
	DKC-F810I-MP2				
	DKC-F810I-MP2UGH				
Cache path control adapter	DKC-F810I-CPEX	6.2/2.8	80		
Cache module (16 GB)	DKC-F810I-CM16G	0.05/0.02 2	4		
Cache module (32 GB)	DKC-F810I-CM32G	0.12/0.05 4	7		
Small memory backup kit	DKC-F810I-BKMS	4.2/1.9	40 <sup>2</sup>		
Large memory backup kit	DKC-F810I-BKML	4/1.8	50 <sup>2</sup>		
Cache flash memory (SSD) (128 GB)	DKC-F810I-BMM128	0.18/0.08	4 <sup>3</sup>		
Cache flash memory (SSD) (256 GB)	DKC-F810I-BMM256	0.15/0.07	4 <sup>3</sup>		
300 GB, 15 krpm SAS SFF disk drive	DKC-F810I-300KCM DKC-F810I-300KCMC <sup>3,4</sup>	0.66/0.3	8.6 <sup>3</sup>	Included in drive chassis specs	
600 GB, 15 krpm SAS SFF disk drive	DKC-F810I-600KGM <sup>4</sup>	0.66/0.3	8.5 <sup>3</sup>		
600 GB, 10 krpm SAS SFF disk drive	DKC-F810I-600JCM DKC-F810I-600JCMC <sup>3,4</sup>	0.66/0.3	8.0 <sup>3</sup>		
900 GB, 10 krpm SAS SFF disk drive	DKC-F810I-900JCM DKC-F810I-900JCMC <sup>3,4</sup>	0.66/0.3	9.0 <sup>3</sup>		
1.2 TB, 10 krpm SAS SFF disk drive	DKC-F810I-1R2JCM DKC-F810I-1R2JCMC <sup>3,4</sup>	0.66/0.3	8.7 <sup>3</sup>		
1.8 TB, 10 krpm SFF	DKC-F810I-1R8JGM <sup>4</sup>	0.66/0.3	8.5 <sup>3</sup>		



Component	Component model number	Weight (lb/kg)	Power consumption (VA)	Heat output	Airflow (m <sup>3</sup> /min)
2.4 TB, 10 krpm SFF	DKC-F810I-2R4JGM	0.3	9.4 <sup>3</sup>		
4 TB, 7.2 krpm SAS LFF disk drive	DKC-F810I-4R0H3M	0.83/0.83	14.8 <sup>3</sup>		
	DKC-F810I-4R0H3MC <sup>3,4</sup>				
600 GB, 10 krpm disk drive in LFF canister	DKC-F810I-600J5M	0.66/0.3	14.8 <sup>3</sup>		
	DKC-F810I-600J5MC <sup>3</sup>				
6 TB, 7.2 krpm SAS LFF disk drive	DKC-F810I-6R0H9M <sup>4</sup>	1.9/0.86	14.8 <sup>3</sup>		
400 GB, LFF SSD	DKC-F810I-400M5M	1.8/0.8	7.1 <sup>3</sup>		
400 GB, SFF MLC SSD	DKC-F810I-400MCM	0.29/0.13	6.7 <sup>3</sup>		
800 GB, SFF MLC SSD	DKC-F810I-800MCM	0.29/0.13	6.7 <sup>3</sup>		
960 GB, SFF, SSD	DKC-F810I-960MGM	0.51/0.23	7.1 <sup>3</sup>		
1.9 TB, SFF, SSD	DKC-F810I-1R9MGM	0.51/0.23	7.1 <sup>3</sup>		
3.8 TB, SFF, SSD	DKC-F810I-3R8MGM	0.51/0.23	7.1 <sup>3</sup>		
7.6 TB, SFF, SSD	DKC-F810I-7R6MGM	0.51/0.23	8.4 <sup>3</sup>		
15 TB, SFF, SSD	DKC-F810I-15RMGM	0.51/0.23	8.4 <sup>3</sup>		
Hitachi Accelerated Flash 1.75 TB FMD	DKC-F810I-1R6FM	3.08/1.4	18.0 <sup>3</sup>		
	DKC-F710I-1R6FM				
Hitachi Accelerated Flash 3.5 TB FMD	DKC-F810I-3R2FM	3.08/1.4	19.0 <sup>3</sup>		
	DKC-F710I-3R2FM				
Hitachi Accelerated Flash 1.75 TB FMD DC2	DKC-F810I-1R6FN	3.08/1.4	26.0 <sup>3</sup>	25.0 <sup>3</sup>	
Hitachi Accelerated Flash 3.5 TB FMD DC2	DKC-F810I-3R2FN	3.08/1.4	26.0 <sup>3</sup>	25.0 <sup>3</sup>	
Hitachi Accelerated Flash 7 TB FMD DC2	DKC-F810I-6R4FN	3.08/1.4	26.0 <sup>3</sup>	25.0 <sup>3</sup>	
	DKC-F810I-7R0FP				

Component	Component model number	Weight (lb/kg)	Power consumption (VA)	Heat output	Airflow (m <sup>3</sup> /min)
Hitachi Accelerated Flash 14 TB FMD DC2	DKC-F810I-14RFP	3.08/1.4	26.0 <sup>3</sup>	25.0 <sup>3</sup>	
Hitachi Accelerated Flash 7 TB FMD HDE	DKC-F810I-7R0FPE	3.08/1.4	26.0 <sup>3</sup>	25.0 <sup>3</sup>	
Hitachi Accelerated Flash 14 TB FMD HDE	DKC-F810I-14RFPE	3.08/1.4	26.0 <sup>3</sup>	25.0 <sup>3</sup>	
Back-end director (disk adapter)	DKC-F810I-SCA	4.2/1.9	105	100	—
Encrypting back-end director	DKC-F810I-ESCA	3.3/2.0	110	105	—
iSCSI 8-port 10G front-end director	DKC-F810I-8IS10	4.1/1.9	126	120	—
Fibre Channel 16-port 16G front-end director	DKC-F810I-16FC16	4.6/2.1	179	170	—
Fibre Channel 16-port 8G front-end director	DKC-F810I-16FC8	3.3/2.0	116	110	—
Fibre Channel 8-port 16G front-end director	DKC-F810I-8FC16	5.3/2.4	116	110	—
Fibre Channel over Ethernet (FCoE) front-end director	DKC-F810I-16FE10	4.8/2.1	179	170	—
Mainframe Fibre Channel 16-port 8G front-end director for Shortwave	DKC-F810I-16MS8	5.3/2.4	126	120	—
Mainframe Fibre Channel 16-port 16G front-end director for Shortwave	DKC-F810I-16MS16	5.3/2.4	137	130	—
Mainframe Fibre Channel 16-port 8G	DKC-F810I-16ML8	5.3/2.4	126	120	—

Component	Component model number	Weight (lb/kg)	Power consumption (VA)	Heat output	Airflow (m <sup>3</sup> /min)
front-end director for Longwave					
Mainframe Fibre Channel 16-port 16G front-end director for Longwave	DKC-F810I-16ML16	5.3/2.4	137	130	—
SFP for 8 Gbps Longwave	DKC-F810I-1PL8	0.044/0.02	—	—	—
SFP for 8 Gbps Shortwave	DKC-F810I-1PS8	0.044/0.02	—	—	—
SFP for 16 Gbps Longwave	DKC-F810I-1PL16	0.044/0.02	—	—	—
SFP for 16 Gbps Shortwave	DKC-F810I-1PS16	0.044/0.02	—	—	—
PDU 30A, single phase (Americas)	PDU-121112F10	9.9/4.5	—	—	—
PDU 32 A, single phase (EMEA/APAC)	A3CR-123294-51	5.73/2.6	—	—	—
PDU 30A, three phase (Americas)	PDU-32C13800F10	18/8.0	—	—	—
PDU 32A, three phase (EMEA/APAC)	A3CK-243694-50	11/5.2	—	—	—
Controller chassis bezel	DKC-F810I-BCH	8.2/3.7	—	—	—
Drive chassis bezel	DKC-F810I-BUH	8.2/5.3	—	—	—
Flash module chassis bezel	DKC-F810I-BFH	6.2/2.8	—	—	—
Hitachi Universal V2 Rack	A3BF-600-1200-V2	222/101	—	—	—
Controller Rail Kit	A34V-700-800-CBX	7.4/3.4	—	—	—
Corner Guide Rail Kit (FBX)	A3BF-HK-GL-740-1	4.4/2	—	—	—

Component	Component model number	Weight (lb/kg)	Power consumption (VA)	Heat output	Airflow (m <sup>3</sup> /min)
Corner Guide Rail Kit (SFF / LFF)	A3BF-HK-GL-740-1	4.4/2	—	—	—
Front Door	A3BF-DR-R800	50.6/23	—	—	—
Left side panel with Hitachi branding	A3BF-Z-PAN-BR-L	39.6/18	—	—	—
Right side panel with Hitachi branding	A3BF-Z-PAN-BR-R	39.6/18	—	—	—
Universal Rail Kit	A34V-600-850-UNI	6.2/2.8	—	—	—
Power Cord Kit, CBX chassis, USA	DKC-F810I-PLUC	9.9/4.5	—	—	—
Power Cord Kit, SFF / LFF drive chassis, USA	DKC-F810I-PHUC	9.9/4.5	—	—	—
Power Cord Kit, FMD drive chassis, USA	DKC-F810I-PFUC	4.4/2.0	—	—	—
Power Cord Kit, controller chassis, EU	DKC-F810I-PLEC	2/0.7	—	—	—
Power Cord Kit, SFF/LFF drive chassis, EU	DKC-F810I-PHEC	6.8/3.1	—	—	—
Power Cord Kit, FMD drive chassis, EU	DKC-F810I-PFEC	3.1/1.4	—	—	—
Power Cord Kit, controller chassis, China	DKC-F810I-PLCC	1.5/0.7	—	—	—
Power Cord Kit, SFF/LFF drive chassis, China	DKC-F810I-PHCC	6.6/3.0	—	—	—
Power Cord Kit, FMD drive chassis, China	DKC-F810I-PFCC	2.9/1.3	—	—	—
Inter-Controller Connecting Kit, 5 m	DKC-F810I-MOD5	4.4/2.0	1	—	—

Component	Component model number	Weight (lb/kg)	Power consumption (VA)	Heat output	Airflow (m <sup>3</sup> /min)
Inter-Controller Connecting Kit, 30 m	DKC-F810I-MOD30	7.7/3.5	1	—	—
Inter-Controller Connecting Kit	DKC-F810I-MOD1J	17.2/7.8	1	—	—
Inter-Controller Connecting Kit	DKC-F810I-MFC5	1.75/0.8	—	—	—
Inter-Controller Connecting Kit	DKC-F810I-MFC30	5.1/2.3	—	—	—
Inter-Controller Connecting Kit	DKC-F810I-MFC1J	14.3/6.5	—	—	—
Device Interface Cable (ENC), 1 m	DKC-F810I-CC1	2.4/1.1	—	—	—
Device Interface Cable (ENC), 2 m	DKC-F810I-CC2	3.75/1.7	—	—	—
Device Interface Cable (ENC), 4 m	DKC-F810I-CC4	6.4/2.9	—	—	—
Device Interface Cable (ENC), 5 m	DKC-F810I-FC5	2.4/1.1	—	—	—
Device Interface Cable (ENC), 30 m	DKC-F810I-FC30	6.6/3.0	—	—	—
Device Interface Cable (ENC), 100 m	DKC-F810I-FC1J	18/8.2	—	—	—

**Notes:**

1. Maximum values with all fans spinning at maximum speed.
2. Power is consumed during the battery back-up time only. The idle power is included in DW700-CBX.
3. Actual values at a typical I/O condition. (Random read and write, 50 IOPS for HDD, 2500 IOPS for SSD/FMD, data length of 8 Kbytes) These values can increase for future compatible drives.
4. The component does not contain BNST.
5. Actual values at a typical I/O condition. (Random read and write, 50 IOPS for HDD, 2500 IOPS for SSD/FMD, data length of 8 Kbytes)  
These values can increase for future compatible drives.

## Appendix F: Power distribution units for Hitachi Universal V2 Rack

The Hitachi Universal V2 Rack is equipped with specific power distribution units (PDU) for Americas, APAC, and EMEA regions. The PDUs can provide electrical power to the storage system in a single-phase or three-phase configuration.



### Caution:

- Before installing third-party devices into the rack, check the electrical current draw of each device. Verify the electrical specifications and allowable current load on each PDU before plugging the device into the PDU.
- Balance the electrical current load between available PDUs.

### Americas single-phase PDU 1P30A-8C13-3C19UL.P

The following figure and table describes the specifications of the PDU.

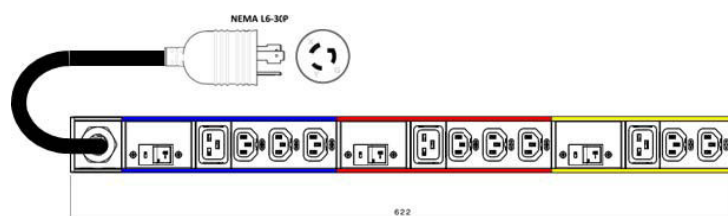
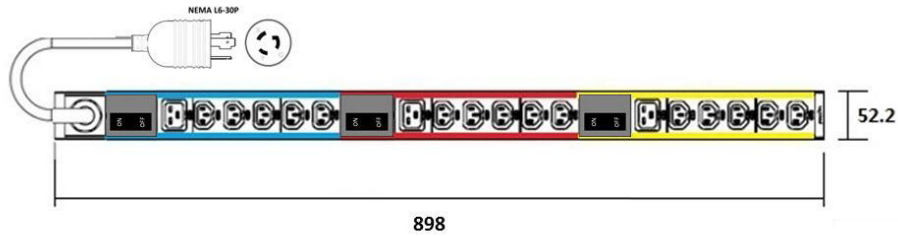

**Figure 39 Americas PDU for the Hitachi Universal V2 Rack (Single-phase PDU 1P30A-8C13-3C19UL.P)**

Part Number	Region	Phase	Description
1P30A-8C13-3C19U L.P	Americas	Single	<ul style="list-style-type: none"> <li>▪ 208V, 30A (24A rated) 60Hz</li> <li>▪ 8 IEC C13 + 3 IEC C19 sockets</li> <li>▪ NEMA L6-30P input power plug</li> <li>▪ 4.5 m (14.76 feet) cable</li> </ul>

## Americas single-phase PDU 1P30A-15C13-3C19UL.P

The following figure and table describes the specifications of the PDU.

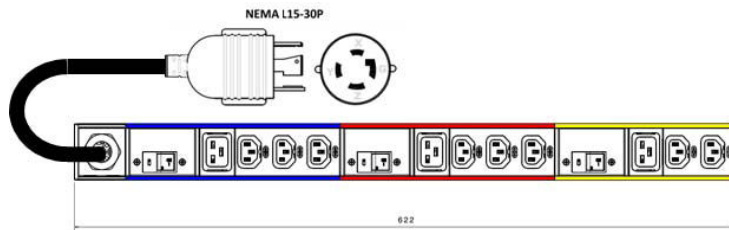

**Figure 40 Americas PDU for the Hitachi Universal V2 Rack (Single-phase PDU 1P30A-15C13-3C19UL.P)**

Part Number	Region	Phase	Description
1P30A-15C13-3C19UL.P	Americas	Single	<ul style="list-style-type: none"> <li>208V, 30A (24A rated) 60Hz</li> <li>15 IEC C13 + 3 IEC C19 sockets</li> <li>NEMA L6-30P input power plug</li> <li>4.5 m (14.76 feet) cable</li> </ul>

## Americas three-phase PDU 3P30A-8C13-3C19UL.P

The following figure and table describes the specifications of the PDU.



**Figure 41 Americas PDU for the Hitachi Universal V2 Rack (Three-phase PDU 3P30A-8C13-3C19UL.P)**

Part Number	Region	Phase	Description
3P30A-8C13-3C19U L.P	Americas	Three	<ul style="list-style-type: none"> <li>▪ 208V 3P, 30A (24A rated) 60Hz</li> <li>▪ 8 IEC C13 + 3 IEC C19 sockets</li> <li>▪ NEMA L15-30P input power plug</li> <li>▪ 4.5 m (14.76 feet) cable</li> </ul>

## Americas three-phase PDU 3P30A-15C13-3C19UL.P

The following figure and table describes the specifications of the PDU.



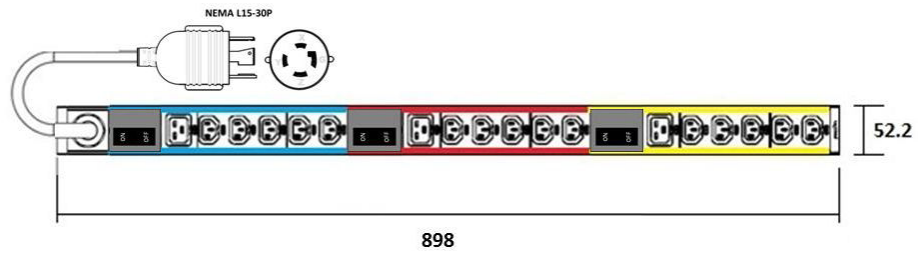
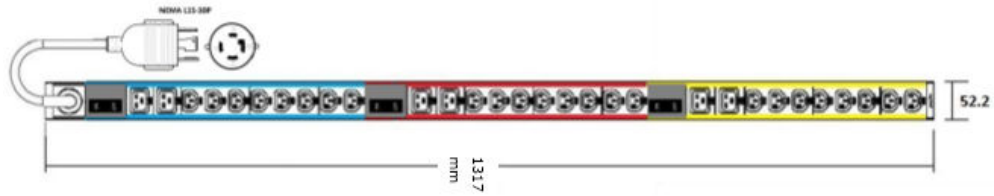

**Figure 42 Americas PDU for the Hitachi Universal V2 Rack (Three-phase PDU 3P30A-15C13-3C19UL.P)**

Part Number	Region	Phase	Description
3P30A-15C13-3C19 UL.P	Americas	Three	<ul style="list-style-type: none"> <li>208V 3P, 30A (24A rated) 60Hz</li> <li>15 IEC C13 + 3 IEC C19 sockets</li> <li>NEMA L15-30P input power plug</li> <li>4.5 m (14.76 feet) cable</li> </ul>

## Americas three-phase PDU 3P30A-24C13-6C19UL.P

The following figure and table describes the specifications of the PDU.

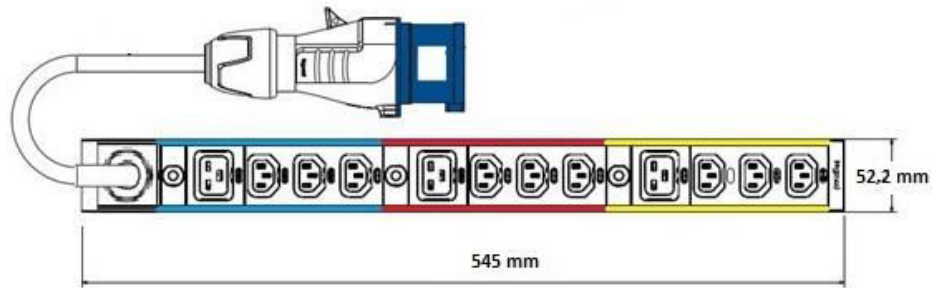

**Figure 43 Americas PDU for the Hitachi Universal V2 Rack (Three-phase PDU 3P30A-24C13-6C19UL.P)**

Part Number	Region	Phase	Description
3P30A-24C13-6C19 UL.P	Americas	Three	<ul style="list-style-type: none"> <li>▪ 208V 3P, 30A (24A rated) 60Hz</li> <li>▪ 24 IEC C13 + 6 IEC C19 sockets</li> <li>▪ NEMA L15-30P input power plug</li> <li>▪ 4.5 m (14.76 feet) cable</li> </ul>

## APAC and EMEA single-phase PDU 1P32A-9C13-3C19CE.P

The following figure and table describes the specifications of the PDU.

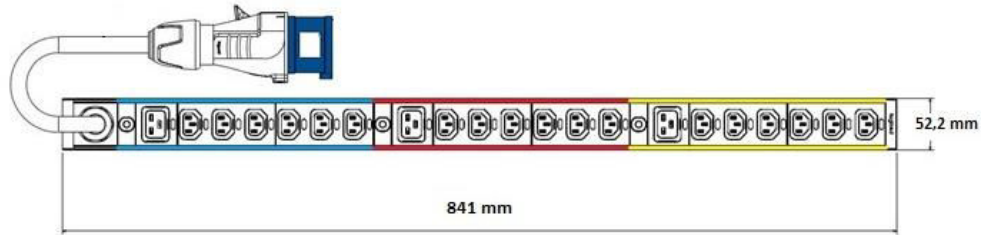

**Figure 44 APAC and EMEA PDU for the Hitachi Universal V2 Rack (Single-phase 1P32A-9C13-3C19CE.P)**

Part Number	Region	Phase	Description
1P32A-9C13-3C19C E.P	APAC and EMEA	Single	<ul style="list-style-type: none"> <li>▪ 230V max. 32A 50Hz / 60Hz</li> <li>▪ 9 IEC C13 + 3 IEC C19 sockets</li> <li>▪ IEC309 Blue 2P + E input power plug</li> <li>▪ 4.5 m (14.76 feet) cable</li> </ul>

## APAC and EMEA single-phase PDU 1P32A-18C13-3C19CE.P

The following figure and table describes the specifications of the PDU.

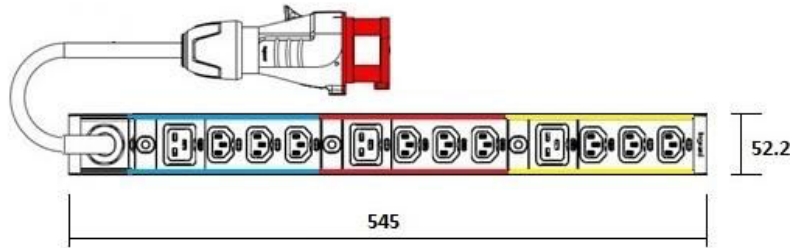

**Figure 45 APAC and EMEA PDU for the Hitachi Universal V2 Rack (Single-phase 1P32A-18C13-3C19CE.P)**

Part Number	Region	Phase	Description
1P32A-18C13-3C19 CE.P	APAC and EMEA	Single	<ul style="list-style-type: none"> <li>▪ 230V max. 32A 50Hz / 60Hz</li> <li>▪ 18 IEC C13 + 3 IEC C19 sockets</li> <li>▪ IEC309 Blue 2P + E input power plug</li> <li>▪ 4.5 m (14.76 feet) cable</li> </ul>

## APAC and EMEA three-phase PDU 3P16A-9C13-3C19CE.P

The following figure and table describes the specifications of the PDU.

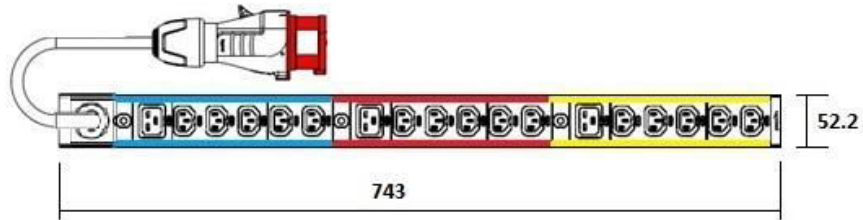

**Figure 46 APAC and EMEA PDU for the Hitachi Universal V2 Rack (Three-phase 3P16A-9C13-3C19CE.P)**

Part Number	Region	Phase	Description
3P16A-9C13-3C19C E.P	APAC and EMEA	Three	<ul style="list-style-type: none"> <li>▪ 400V max. 3x 16A 50Hz / 60Hz</li> <li>▪ 9 IEC C13 + 3 IEC C19 sockets</li> <li>▪ IEC309 Red 3P + N + E input power plug</li> <li>▪ 4.5 m (14.76 feet) cable</li> </ul>

## APAC and EMEA three-phase PDU 3P16A-15C13-3C19CE.P

The following figure and table describes the specifications of the PDU.

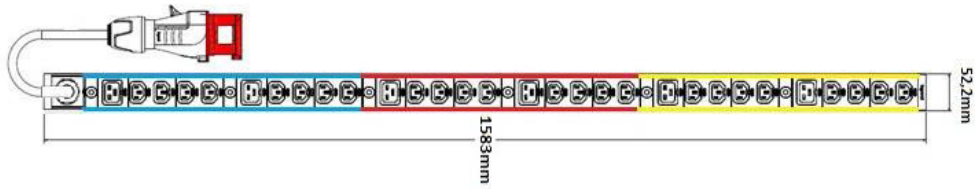

**Figure 47 APAC and EMEA PDU for the Hitachi Universal V2 Rack (Three-phase 3P16A-15C13-3C19CE.P)**

Part Number	Region	Phase	Description
3P16A-15C13-3C19 CE.P	APAC and EMEA	Three	<ul style="list-style-type: none"> <li>▪ 400V max. 3x 16A 50Hz / 60Hz</li> <li>▪ 15 IEC C13 + 3 IEC C19 sockets</li> <li>▪ IEC309 Red 3P + N + E input power plug</li> <li>▪ 4.5 m (14.76 feet) cable</li> </ul>

## APAC and EMEA three-phase PDU 3P32A-24C13-6C19CE.P

The following figure and table describes the specifications of the PDU.



**Figure 48 APAC and EMEA PDU for the Hitachi Universal V2 Rack (Three-phase 3P32A-24C13-6C19CE.P)**

Part Number	Region	Phase	Description
3P32A-24C13-6C19 CE.P	APAC and EMEA	Three	<ul style="list-style-type: none"> <li>▪ 400V max. 3x 32A 50Hz / 60Hz</li> <li>▪ 24 IEC C13 + 6 IEC C19 sockets</li> <li>▪ IEC309 Red 3P + N + E input power plug</li> <li>▪ 4.5 m (14.76 feet) cable</li> </ul>

---

## Appendix G: Safety requirements

Install Hitachi Vantara equipment in accordance with the local safety codes and regulations that apply to the facility. This chapter describes additional safety information that can apply to your facility. Read and follow the safety guidelines in this chapter before installing the equipment.

### General safety guidelines

Observe the following general site guidelines:

- **General requirements:** The data center must comply with all applicable safety regulations, standards, and requirements for installing and operating industrial computer equipment similar to a storage system.
- **Fire protection:** The data center must have an operational fire protection system appropriate for use with computer and electrical equipment.
- **Hazards:** The data center must be free of hazards (for example, cables on the floor that can block access or cause people to trip).
- **Equipment modifications:** Do not make mechanical or electrical modifications to the equipment. Hitachi Vantara is not responsible for regulatory compliance of a modified Hitachi Vantara product.
- **Earthquake safety:** To minimize personal injury in the event of an earthquake, securely fasten the control and drive chassis to a rigid structure extending from the floor to the ceiling or from the walls of the room in which the system is located.
- **Cabling:** Do not block walkways when routing cables. Do not place heavy materials on cables. Do not place cables near any possible source of heat.
- **Warning and safety labels:** Safety warnings, cautions, and instructions in various languages are attached to the storage system components. The safety warnings provide guidelines to follow when working with any equipment. Before working on the storage system, read all safety and warning labels attached to it. If the labels become dirty, damaged, unreadable, or peel off, contact the Hitachi Vantara support center.
- **Authorized personnel:** Allow only qualified and authorized personnel (for example, a certified electrician) to perform hazardous tasks.



## Work safety guidelines

Observe the following site guidelines:

- Do not wear loose clothing that could get caught in the equipment or mounting hardware. Fasten your tie or scarf and roll up your sleeves.
- Wear safety glasses when working under conditions that are hazardous to your eyes.
- Do not perform any action that creates a potential hazard to people or makes the equipment or rack unsafe.
- Keep walkways clear of tools, power cables, and parts to prevent them from being stepped on or causing people to trip and fall over them.
- Do not work on the equipment or disconnect cables during a thunderstorm, when wearing a wool sweater or other heavy wool clothing, or when power is applied.
- Keep floors dry to prevent slips and falls.
- Do not use ungrounded power cables.
- Keep the area clear and dust-free during and after installation.
- Do not block or cover equipment openings. Ensure that all equipment has adequate airflow. Failure to follow these guidelines can cause overheating and affect the system reliability.
- If you notice unusual heat generation, odors, or smoke emission, shut off the power feed to the equipment and contact a maintenance engineer. Leaving such conditions unattended can result in hazardous physical conditions and equipment failure.
- The rack is equipped with casters so that it can be moved short distances to position it for final installation. Use enough personnel (minimum of two) when moving a rack, especially on sloping loading docks and ramps to a raised computer room floor. Move the cabinet slowly and deliberately, and make sure that the floor is free from foreign objects and cables that the cabinet could roll over.



**Warning:** To avoid injury, wear protective footwear when moving equipment.

## Warning about moving parts

Even though customers do not install or maintain equipment, these guidelines are provided to prevent possible injury when working with authorized service personnel. Observe the following warning related to moving parts:

- Tuck in any loose clothing so that it cannot be caught by a moving or rotating part such as a fan.
- Tie up long hair.
- Unless otherwise specifically instructed, do not supply power to any device that contains rotating or moving parts that are not correctly covered.

## Electrical safety guidelines

Even though customers do not install or maintain equipment, these guidelines are provided to prevent possible injury when working with authorized service personnel in the area where equipment is installed. Observe the following electrical safety guidelines:

- Disconnect all power before installation, deinstallation, or moving equipment.
- Ensure that the voltage and frequency of your power source match the voltage and frequency required by the system.
- All equipment should be properly grounded for proper operation and safety. To reduce the risk of electric shock or damage to equipment, follow proper grounding procedures.

### Preventing electric shock

- Before starting work, note where the emergency power-off switches are located, and be sure you know how to operate them.
- Before starting work, be sure there are no potential electric hazards in the maintenance area such as insufficient grounding or a wet floor.

## Appendix H: Regulatory specifications

This appendix provides regulatory information for storage systems and includes tables with explanations of regulatory requirement statements from various countries.

### Regulatory compliance

This equipment has been tested and is certified to meet the following certifications.

**Table 38 Compliance certifications**

Standard	Specification	Mark on the product	Country
Electronic emission control	FCC Part 15 Subpart B Class A	Yes (FCC)	U.S.A
Electronic emission control	FCC Part 15 Subpart B Class A:2010, Class A ICES-003 Issue 4 Class A	Yes (UL)	Japan
Safety certification	TUV Safety Report and TUV-NRTL Certification, FCC Verification Report	Yes (TUV)	EU, North America
Electronic emission certifications	TUV Safety Report, EMC Report, TUV GS License, EMC Certificate, CE Mark	Yes (CE Mark)	European Union
Electronic emission control	CB Report and Certificate	Yes (TUV)	Worldwide
Electronic emission control	Test Report for C-Tick Approval	Yes	Australia and New Zealand
VCCI Registration for Product and Accessories	VCCI Class A	Yes (VCCI)	Japan

Standard	Specification	Mark on the product	Country
Safety certification	GOST Certificate for Product and Accessories	Yes (GOST)	Russia
Electronic emission control	BSMI Approval for Product and Accessories	Yes (BSMI)	Taiwan
Electronic emission control	RRL Approval and KTL Safety Approval	Yes (RRL)	Korea
Safety certification	IRAM Approval	Yes	Argentina
Electronic emission control	CCC Approval for Switching Power Supply	Yes (IRAM)	China

Table 39 Compliance certifications by region

Certification	Region	Regulatory	Standard	Certificate No. and Report No.	
Safety	Worldwide	CB	IEC60950-1:2005+A1	Certificate Numbers	JPTUV-053187-M2 JPTUV-053211-A1 PTUV-048773-M1
				Report Numbers	12030097 12030890 12028263
				Photo Documentation Numbers	12030097 12030890 12028263
	North America	cTUVus	UL60950-1:2007 CAN/CSA-C22.2 No.60950-1-07+A1	Test Report No. Certificate Numbers	USA-JT 12030098 CU72133020 CU72133022 CU72120935
	European Union	TUV	+A11+A1+A12	Certificate Numbers	S1-50266086 S1-50266254

Certification	Region	Regulatory	Standard	Certificate No. and Report No.	
					S1-50245594
	Argentina	IRAM	IEC60950-1:2005+A1	Certificate Numbers	RA3385104E,204E,205E RA3385103E,202E,203E RA3283003E
Safet y EMC	Russia	EAC	TP TC 004/2011 TP TC 020/2011	Certificate Numbers	RA3283003E RU C-JP.AR46.B.60400 RU C-JP.AR46.B.60634
	North America	FCC	FCC Part15 Subpart B Class A EICES-003 Issue:2012 Class A	Test Report No.	10033930S-C 10057416S-C 10162445S-D
	European Union	EN	EEN55022:2010 EEN55024:2010 EEN61000-3-2:2006 +A1+A2 EEN61000-3-3:2008	Certificate No. Test Report Numbers	CJ50268193 12030583-001 12030583-003 12030583-004
EMC	Australia and New Zealand	C-Tick RCM	AS/NZS CISPR 22:2009+A1 Class A	Test Report Numbers	10033930S-B 10057416S-B 10162445S-C
	Taiwan	BSMI	CNS13429¥CNS14336-1	Declaration of Conformity	Declaration of Conformity
	South Korea	KCC	KN22KN24	Certificate No.	MSIP-REM-HTB-DKC810
	Region	Regulatory	Standard	Model	Certificate No.
Safet y EMC	China	CCC	GB4943-2011GB9254-2008GB17625.1-2003	SBX/UBX_SWPSTDPS-600FB XX	2011010907455767
				FBX_SWPSPPD6001	2012010907575263

## US FCC Notice

FCC Notice

Federal Communications Commission

This equipment has been tested and found to comply with the limits for a Class A digital device, pursuant to part 15 of the FCC Rules. These limits are designed to provide reasonable protection against harmful interference when the equipment is operated in a commercial environment.

This equipment generates, uses, and can radiate radio frequency energy and, if not installed and used in accordance with the instruction manual, may cause harmful interference to radio communications. Operation of this equipment in a residential area is likely to cause harmful interference, in which case users will be required to correct the interference at their own expense.

### Electronic emissions testing

EMI testing was conducted with shielded cables. To comply with the FCC regulations, you must use shielded cables with your installation.

The EMI tests were performed with the following configurations:

DKC810I-CBX+DKC+F810I-SBX

DKC810I-CBX+DKC+F810I-SBX+DKC-F810I-UBX

Copies of the Underwriters Laboratories EMI compliance certificates are located at the end of this chapter.

If trouble occurs in another configuration, a user may be requested to take appropriate preventive measures.

## European Declaration of Conformity

	<p><b>Warning</b> This equipment complies with the requirements relating to electromagnetic compatibility, EN 55022 class A for ITE, the essential protection requirement of Council Directive 89/336/EEC on the approximation of the laws of the Member States relating to electromagnetic compatibility.</p>
---	--

"EINE LEICHT ZUGÄNGLICHE TRENN-VORRICHTUNG, MIT EINER KONTAKT-ÖFFNUNGSWEITE VON MINDESTENS 3mm IST IN DER UNMITTELBAREN NÄHE DER VERBRAUCHERANLAGE ANZUORDEN (4-POLIGE ABSCHALTUNG)."

**Maschinen lärm informations verordnung 3. GSGV, 18.01.1991:** Der "höchste" Schalldruckpegel beträt 70 db (A) oder weniger gemäß ISO 7779

CLASS 1 LASER PRODUCT



**Warning:** This is a Class A product. In a domestic environment this product may cause radio interference in which case the user may be required to take adequate measures.

**Warning:** Dies ist ein Produkt der Klasse A. In nichtgewerblichen Umgebungen können von dem Gerät Funkstörungen ausgehen, zu deren Beseitigung vom Benutzer geeignete Maßnahmen zu ergreifen sind.

## Notice of export controls

Export of technical data contained in this document may require an export license from the United States government and/or the government of Japan. Contact the Hitachi Legal Department for any export compliance questions.

## China RoHS

	This symbol displays requirements for controlling pollution caused by electronic information products.
--	--

## Hazardous and toxic substances

Table 40 Hazardous and toxic substances

Toxic and hazardous substances and elements						
Unit	Lead (PB)	Mercury (Hg)	Cadmium (Cd)	Hexavalent Chromium (Cr (VI))	Polybrominated biphenyls (PBB)	Polybrominated diphenyl ethers (PBDE)
Controller chassis	X	O	O	O	O	O
Drive chassis	X	O	O	O	O	O

### Toxic and hazardous substances and elements

The Symbol O indicates that this toxic or hazardous substances contained in all of the homogeneous materials used for this part is below this limit requirement in SJ/T 11363-2006.

The symbol X indicates that this toxic or hazardous substances contained in at least one of the homogeneous materials used for this part is above the limit requirement in SJ/T 11363-2006.

## Disposal



**Note:** This symbol on the product or on its packaging means that your electrical and electronic equipment should be disposed at the end of life separately from household wastes. There are separate collection systems for recycling EU and many cities in the USA. For more information, contact the local authority or the dealer where you purchased the product.

## Recycling



The cache backup battery unit includes a nickel-hydride battery. A nickel-hydride battery should be recycled when it is no longer usable. When you replace the battery unit, do not dispose of the old one in the trash. Recycle the battery instead. The mark posted on the battery unit is a three-arrow mark that means a recyclable part.

## Electronic emissions certificates

Copies of the Underwriters Laboratories EMI compliance certificates are located on the following pages. If necessary, contact customer support for detailed information.





Test report No. : 10162445S-D  
 Page : 1 of 22  
 Issued date : January 31, 2013

---

## EMI TEST REPORT

**Test Report No. : 10162445S-D**

**Applicant:** Hitachi Ltd.

**Type of Equipment:** Disk Storage System - RAID800

**Model No.:** DKC8101-CBXA, DKC-F8101-CBXB  
 DKC-F8101-SBX (MDKC8101-SBX (x8))  
 DKC-F8101-UBX (MDKC8101-UBX (x8))  
 DKC-F8101-FBX (MNF100R8-BOX (x4))

**Test regulation:** FCC Part 15 Subpart B:2013 ClassA  
 ICES-003 Issue 5:2012 ClassA

**Test result:** Complied

1. This test report shall not be reproduced in full or partial, without the written approval of UL Japan, Inc.
2. The results in this report apply only to the sample tested.
3. This sample tested is in compliance with the limits of the above regulation.
4. The test results in this test report are traceable to the national or international standards.
5. This test report must not be used by the customer to claim product certification, approval, or endorsement by any agency of the Federal Government.
6. The opinions and the interpretations to the result of the description in this report are outside scopes where UL Japan has been accredited.

**Date of test:** January 21 - 24 , 2014

**Representative test engineer:** M. Hosaka  
 Makoto Hosaka  
 Engineer of WiSE Japan,  
 UL Verification Service

**Approved by:** T. Isozaki  
 Tetsuro Isozaki  
 Leader of WiSE Japan,  
 UL Verification Service





The testing in which "Non-accreditation" is displayed is outside the accreditation scopes in UL Japan.  
 There is no testing item of "Non-accreditation".

---

**UL Japan, Inc.**  
**Shonan EMC Lab.**  
 1-22-3 Megumioka, Hiratsuka-shi, Kanagawa-ken, 259-1220 JAPAN  
 Telephone: +81 463 50 6400  
 Facsimile: +81 463 50 6400

13-EM-F0429

Figure 49 UL EMI compliance certificate (1 of 3)



Test report No. : 10162445S-C  
 Page : 1 of 23  
 Issued date : January 31, 2014

---

## EMI TEST REPORT

### Test Report No.: 10162445S-C



<b>Applicant:</b>	<b>Hitachi Ltd.</b>
<b>Type of Equipment:</b>	<b>Disk Storage System - RAID800</b>
<b>Model No.:</b>	<b>DKC810I-CBXA, DKC-F810I-CBXB DKC-F810I-SBX (MDKC810I-SBX (x8)) DKC-F810I-UBX (MDKC810I-UBX (x8)) DKC-F810I-FBX (MNF100R8-BOX (x4))</b>
<b>Test standard:</b>	<b>AS/NZS CISPR 22:2009+A1:2010 classA</b>
<b>Test Result:</b>	<b>Complied</b>

1. This test report shall not be reproduced in full or partial, without the written approval of UL Japan, Inc.
2. The results in this report apply only to the sample tested.
3. This sample tested is in compliance with the limits of the above standard.
4. The test results in this test report are traceable to the national or international standards.
5. The opinions and the interpretations to the result of the description in this report are outside scopes where UL Japan has been accredited.

**Date of test:** January 21 - 24, 2014

**Representative test engineer:** *M. Hosaka*  
 Makoto Hosaka  
 Engineer of WISE Japan,  
 UL Verification Service

**Approved by:** *I. Isozaki*  
 Ichiro Isozaki  
 Leader of WISE Japan,  
 UL Verification Service

The testing in which "Non-accreditation" is displayed is outside the accreditation scopes in UL Japan.

There is no testing item of "Non-accreditation".

---

**UL Japan, Inc.**  
**Shonan EMC Lab.**  
 1-22-3 Megumiyaoka, Hiratsuka-shi, Kanagawa-ken, 259-1220 JAPAN  
 Telephone: +81 463 50 6400  
 Facsimile: +81 463 50 6401

13-EM-F0429

Figure 50 Test certificate (2 of 3)

		<b>Ref. Certif. No.</b> JPTUV-048773-M1
<b>IEC SYSTEM FOR MUTUAL RECOGNITION OF TEST CERTIFICATES FOR ELECTRICAL EQUIPMENT (IECEE) CB SCHEME</b>		<b>SYSTEME CEI D'ACCEPTATION MUTUELLE DE CERTIFICATS D'ESSAIS DES EQUIPEMENTS ELECTRIQUES (IECEE) METHODE OC</b>
<b>CB TEST CERTIFICATE</b>		<b>CERTIFICAT D'ESSAI OC</b>
Product Produit	Flash Module Drive Box	
Name and address of the applicant Nom et adresse du demandeur	Hitachi, Ltd. 322-2 Nakazato Odawara-shi, Kanagawa, 250-0872 JAPAN	
Name and address of the manufacturer Nom et adresse du fabricant	Hitachi, Ltd. 322-2 Nakazato Odawara-shi, Kanagawa, 250-0872 JAPAN	
Name and address of the factory Nom et adresse de l'usine	Hitachi, Ltd. 2890 Kozu Odawara-shi, Kanagawa, 256-8510 JAPAN	
Ratings and principal characteristics Valeurs nominales et caractéristiques principales	1) AC 200-240V; 50/60Hz; 2 x 1.3A 2) AC 100-120/200-240V; 50/60Hz; 2x 2.6/1.3A Class I	
Trademark (if any) Marque de fabrique (si elle existe)	HITACHI	
Type of Manufacturer's Testing Laboratories used Type de programme du laboratoire d'essais constructeur	TMP	
Model / Type Ref. Ref. de type	1) MNF100R-BOXxy, MNF100RB-BOXxxx (x, y = 0-9, A-Z or blank) 1) DW-F700-DBFxxx, HT-F405A-DBFxxx (x = A-Z or blank) 2) DF-F850-DBFxxx, HT-F4066-DBFxxx (x = 0-9, A-Z or blank)	
Additional information (if necessary may also be reported on page 2) Les informations complémentaires (si nécessaire, peuvent être indiquées sur la 2 <sup>ème</sup> page)	For model differences, refer to the test report. Re-issue of JPTUV-048773 dated 28.12.2012, due to first modification	
A sample of the product was tested and found to be in conformity with Un échantillon de ce produit a été essayé et a été considéré conforme à la	IEC 60950-1:2005+A1 National differences see test report	
As shown in the Test Report Ref. No. which forms part of this Certificate Comme indiqué dans le rapport d'essais numéro de référence qui constitue partie de ce Certificat	12028263 002	
This CB Test Certificate is issued by the National Certification Body Ce Certificat d'essai OC est établi par l'Organisme National de Certification		
	TÜV Rheinland Japan Ltd. Global Technology Assessment Center 4-2b-2 Kita-Yamata, Tsuzuki-ku Yokohama 224-0021 Japan Phone +81 45 914-3888 Fax +81 45 914-3354 Mail: info@jp.tuv.com Web: www.tuv.com	
Date: 12.07.2013	Signature:	 Dipl.-Ing. (FH) M. Geiser

Figure 51 Test certificate (3 of 3)

# FIPS 140-2 Consolidated Validation Certificate

The encrypting back-end director received FIPS 140-2 certification from the National Institute of Standards and Technology. For more information about security and encryption, contact your Hitachi Vantara sales representative.

## FIPS 140-2 Consolidated Validation Certificate



July 2016

The National Institute of Standards and Technology, as the United States FIPS 140-2 Cryptographic Module Validation Authority, and the Communications Security Establishment Canada, as the Canadian FIPS 140-2 Cryptographic Module Validation Authority; hereby validate the FIPS 140-2 testing results of the cryptographic modules listed below in accordance with the Derived Test Requirements for FIPS 140-2, Security Requirements for Cryptographic Modules. FIPS 140-2 specifies the security requirements that are to be satisfied by a cryptographic module utilized within a security system protecting Sensitive Information (United States) or Protected Information (Canada) within computer and telecommunications systems (including voice systems).

Products which use a cryptographic module identified below may be labeled as complying with the requirements of FIPS 140-2 so long as the product, throughout its life-cycle, continues to use the validated version of the cryptographic module as specified in this consolidated certificate. The validation report contains additional details concerning test results. No reliability test has been performed and no warranty of the products by both agencies is either expressed or implied.

FIPS 140-2 provides four increasing, qualitative levels of security: Level 1, Level 2, Level 3, and Level 4. These levels are intended to cover the wide range and potential applications and environments in which cryptographic modules may be employed. The security requirements cover eleven areas related to the secure design and implementation of a cryptographic module.

The scope of conformance achieved by the cryptographic modules as tested are identified and listed on the Cryptographic Module Validation Program website. The website listing is the official list of validated cryptographic modules. Each validation entry corresponds to a uniquely assigned certificate number. Associated with each certificate number is the module name(s), module versioning information, applicable caveats, module type, date of initial validation and applicable revisions, Overall Level, individual Levels if different than the Overall Level, FIPS-approved and other algorithms, vendor contact information, a vendor provided description and the accredited Cryptographic Module Testing laboratory which performed the testing.

Signed on behalf of the Government of the United States

Signature: Michael Carpenter

Dated: 4 Aug 2016

Chief, Computer Security Division  
National Institute of Standards and Technology

Signed on behalf of the Government of the Canada

Signature: D. Hill

Dated: 4 Aug 2016

Director, Architecture and Technology Assurance  
Communications Security Establishment Canada

# Glossary

## **10 Gb**

10 gigabit Ethernet computer networking standard, with a nominal data rate of 10 Gbps, 10 times as fast as gigabit ethernet.

## **arbitrated loop (AL)**

Arbitrated loop, also known as FC-AL, is a Fibre Channel topology in which devices are connected in a one-way loop fashion in a ring topology. Up to 127 devices may be attached in the loop, but only two can communicate at the same time. Arbitrated loop is an alternative to Fibre Channel switches.

## **array group**

A set of drives in a storage system that have the same capacity and are treated as one RAID unit. An array group contains user data and parity information, which ensures user data integrity in the event of a disk drive failure in the array group.

## **bps**

bits per second. The standard measure of data transmission speeds.

## **cache**

A set of RAM (Random Access Memory) modules used to store data temporarily.

## **capacity**

The amount of data storage space available on a physical storage device, generally measured in bytes (MB, GB, TB, and so on).

## **CCI**

See Command Control Interface.

## **challenge handshake authentication protocol (CHAP)**

An authentication technique for confirming the identity of one computer to another. Described in RFC 1994.

## **CHAP**

See challenge handshake authentication protocol.

## **CLI**

command line interface

## **cluster**

Multiple storage servers working together to respond to multiple read and write requests.

## **cluster capacity**

The total amount of disk space in a cluster, excluding the space required for system overhead and the operating system. Cluster capacity is the amount of space available for all archive data, including original file data, metadata, and redundant data.

## **Command Control Interface (CCI)**

Software used to control volume replication functionality (such as TrueCopy or ShadowImage) by means of commands issued from a host to a storage system. A command device must be set up in the storage system to enable the storage system to receive commands from CCI.

In an open system, Replication Manager uses the CCI configuration definition files to modify copy pair configurations and to acquire configuration information. Copy pair modification processing, such as splitting and resynchronizing copy pairs, is executed on the storage system via CCI.

### **command device**

A dedicated logical volume used to interface with the storage system. Can be shared by several hosts.

### **controller box**

The enclosure that contains the storage system controller. For some models, disk drives may be included as well. Controller boxes come in 2U and 3U versions.

- **CBL:** AC-powered 3U controller box.
- **CBLE:** AC-powered 2U controller box with support for encryption.
- **CBLD:** DC-powered 3U controller box.
- **CBLE:** 3U controller box that supports encryption.
- **CBSL controller box:** A 3U controller box that can contain a maximum of 12 3.5-inch drives.
- **CBSS controller box:** A 2U controller box that can contain a maximum of 24 2.5-inch drives.
- **CBXSL controller box:** A 3U controller box that can contain a maximum of 12 3.5-inch drives.
- **CBXSS controller box:** A 2U controller box that can contain a maximum of 24 2.5 inch drives.

### **CRC**

See cyclic redundancy check.

### **cyclic redundancy check (CRC)**

An error-correcting code designed to detect accidental changes to raw computer data.

### **differential management-logical unit**

### **disaster recovery**

A set of procedures to recover critical application data and processing after a disaster or other failure. Disaster recovery processes include failover and fallback procedures.

### **DMLU**

See differential management-logical unit.

**drive box**

Chassis for mounting drives that connect to the controller box.

- Drive boxes with AC power supply:
  - **DBS, DBL, DBF:** Drive box (2U)
  - **DBX:** Drive box (4U)
  - **DBW:** Drive box (5U)
- Drive boxes with DC power supply:
  - **DBSD:** Drive box (2U)
  - **DBLD:** Drive box (2U)

**drive I/O module**

I/O module for the controller box that has drive interfaces.

**duplex**

The transmission of data in either one or two directions. Duplex modes are full-duplex and half-duplex. Full-duplex is the simultaneous transmission of data in two directions. For example, a telephone is a full-duplex device, because both parties can talk at once. In contrast, a walkie-talkie is a half-duplex device because only one party can transmit at a time.

**ethernet**

A computer networking technology for local-area networks.

**extent**

A contiguous area of storage in a computer file system that is reserved for writing or storing a file.

**fabric**

Hardware that connects workstations and servers to storage devices in a storage-area network (SAN). The SAN fabric enables any server to any storage device connectivity through the use of fibre channel switching technology.

**failback**

The process of restoring a system, component, or service in a state of failover back to its original state (before failure).

**failover**

Automatic switching to a redundant or standby computer server, system, hardware component, or network upon the failure or abnormal termination of the previously active application, server, system, hardware component, or network. Failover and switchover are essentially the same operation, except that failover is automatic and usually operates without warning, while switchover requires human intervention.

**fault tolerance**

A system with the ability to continue operating, possibly at a reduced level, rather than failing completely, when some part of the system fails.

**FC**

Fibre Channel

**FC-AL**

See arbitrated loop.

**FCoE**

Fibre Channel over Ethernet. An encapsulation of Fibre Channel frames over Ethernet networks. This allows Fibre Channel to use 10-gigabit Ethernet networks (or higher speeds) while preserving the Fibre Channel protocol.

**Fibre Channel (FC)**

A technology for transmitting data between computer devices at a data rate of up to 4 Gbps. It is especially suited for attaching computer servers to shared storage devices and for interconnecting storage controllers and drives.

**firmware**

Software embedded into a storage device. It may also be referred to as *microcode*.

**flash module (FMD)**

A high speed data storage device that includes a custom flash controller and several flash memory sub-modules on a single PCB.

**full-duplex**

Transmission of data in two directions simultaneously. For example, a telephone is a full-duplex device because both parties can talk at the same time.

**Gbps**

Gigabit per second.

**gigabit ethernet**

A version of ethernet that supports data transfer speeds of 1 gigabit per second. The cables and equipment are very similar to previous ethernet standards.

**GUI**

graphical user interface

**HA**

High availability.

**half-duplex**

Transmission of data in just one direction at a time. For example, a walkie-talkie is a half-duplex device because only one party can talk at a time.

**HBA**

See host bus adapter.

**host**

One or more host bus adapter (HBA) world wide names (WWN).



**host bus adapter (HBA)**

One or more dedicated adapter cards that are installed in a host, have unique WWN addresses, and provide Fibre Channel I/O connectivity to storage systems, typically through Fibre Channel switches. Unlike general-purpose Ethernet adapters, which handle a multitude of network protocols, host bus adapters are dedicated to high-speed block transfers for optimized I/O performance.

**host I/O module**

I/O module for the controller box . The host I/O module provides interface functions for the host.

**I/O**

input/output

**I/O card**

The I/O card (ENC) is installed in a DBX. It provides interface functions for the controller box or drive box.

**I/O module**

The I/O module (ENC) is installed in a DBS/DBSD/DBL/DBLD/DBF/DBW. It provides interface functions for the controller box or drive box.

**IEEE**

Institute of Electrical and Electronics Engineers. A non-profit professional association best known for developing standards for the computer and electronics industry. In particular, the IEEE 802 standards for local-area networks are widely followed.

**IOPS**

I/Os per second

**iSCSI**

Internet Small Computer Systems Interface

**iSCSI initiator**

iSCSI-specific software installed on the host server that controls communications between the host server and the storage system.

**iSNS**

Internet Storage Naming Service. An automated discovery, management, and configuration tool used by some iSCSI devices. iSNS eliminates the need to manually configure each individual storage system with a specific list of initiators and target IP addresses. Instead, iSNS automatically discovers, manages, and configures all iSCSI devices in your environment.

**LAN**

See local area network.

**load**

In UNIX computing, the system load is a measure of the amount of work that a computer system is doing.

**local area network (LAN)**

A computer network that spans a relatively small geographic area, such as a single building or group of buildings.

**logical**

Describes a user's view of the way data or systems are organized. The opposite of logical is physical, which refers to the real organization of a system. A logical description of a file that it is a quantity of data collected together in one place. The file appears this way to users. Physically, the elements of the file could live in segments across a disk.

**microcode**

The lowest-level instructions directly controlling a microprocessor. Microcode is generally hardwired and cannot be modified. It is also referred to as firmware embedded in a storage subsystem.

**Microsoft Cluster Server**

A clustering technology that supports clustering of two NT servers to provide a single fault-tolerant server.

**pair**

Two logical volumes in a replication relationship in which one volume contains original data to be copied and the other volume contains the copy of the original data. The copy operations can be synchronous or asynchronous, and the pair volumes can be located in the same storage system (in-system replication) or in different storage systems (remote replication).

**pair status**

Indicates the condition of a copy pair. A pair must have a specific status for specific operations. When a pair operation completes, the status of the pair changes to a different status determined by the type of operation.

**parity**

In computers, parity refers to a technique of checking whether data has been lost or written over when it is moved from one place in storage to another or when transmitted between computers.

Parity computations are used in RAID drive arrays for fault tolerance by calculating the data in two drives and storing the results on a third. The parity is computed by XOR'ing a bit from drive 1 with a bit from drive 2 and storing the result on drive 3. After a failed drive is replaced, the RAID controller rebuilds the lost data from the other two drives. RAID systems often have a "hot" spare drive ready and waiting to replace a drive that fails.

**parity group**

See *RAID group*.

**point-to-point**

A topology where two points communicate.

**port**

An access point in a device where a link attaches.

## **primary site**

The physical location of a storage system that contains original data to be replicated and that is connected to one or more storage systems at a remote or secondary site via remote copy connections. A primary site can also be called a "main site" or "local site".

The term "primary site" is also used for host failover operations. In that case, the primary site is the location of the host on which the production applications are running, and the secondary site is the location of the host on which the backup applications that run when the applications at the primary site have failed.

## **RAID**

redundant array of independent disks

A collection of two or more disk drives that presents the image of a single logical disk drive to the system. Part of the physical storage capacity is used to store redundant information about user data stored on the remainder of the storage capacity. In the event of a single device failure, the data can be read or regenerated from the other disk drives.

RAID employs the technique of disk striping, which involves partitioning each drive's storage space into units ranging from a sector (512 bytes) up to several megabytes. The stripes of all the disks are interleaved and addressed in order.

## **RAID group**

A redundant array of inexpensive drives (RAID) that have the same capacity and are treated as one group for data storage and recovery. A RAID group contains both user data and parity information, which allows the user data to be accessed in the event that one or more of the drives within the RAID group are not available. The RAID level of a RAID group determines the number of data drives and parity drives and how the data is "striped" across the drives. For RAID1, user data is duplicated within the RAID group, so there is no parity data for RAID1 RAID groups.

A RAID group can also be called an array group or a parity group.

## **remote path**

A route connecting identical ports on the local storage system and the remote storage system. Two remote paths must be set up for each storage system (one path for each of the two controllers built in the storage system).

## **SAN**

See storage area network.

## **SAS**

See Serial Attached SCSI.

## **SAS cable**

Cable for connecting a controller box and drive box.

## **Secure Sockets Layer (SSL)**

A common protocol for managing the security of message transmission over the Internet.

Two SSL-enabled peers use their private and public keys to establish a secure communication session, with each peer encrypting transmitted data with a randomly generated and agreed-upon symmetric key.

**Serial Attached SCSI (SAS)**

A replacement for Fibre Channel drives in high-performance applications. See also SCSI.

**snapshot**

A term used to denote a copy of the data and data-file organization on a node in a disk file system. A snapshot is a replica of the data as it existed at a particular point in time.

**SNM2**

See Storage Navigator Modular 2.

**storage area network (SAN)**

A network of shared storage devices that contain disks for storing data.

**Storage Navigator Modular 2**

A multi-featured scalable storage management application that is used to configure and manage the storage functions of Hitachi storage systems.

**striping**

A way of writing data across drive spindles.

**target**

The receiving end of an iSCSI conversation, typically a device such as a disk drive.

**URL**

Uniform Resource Locator

**world wide name**

A unique identifier that identifies a particular fibre channel target.

**zoning**

A logical separation of traffic between host and resources. By breaking up into zones, processing activity is distributed evenly.

**Hitachi Vantara**



Corporate Headquarters  
2535 Augustine Drive  
Santa Clara, CA 95054 USA  
[HitachiVantara.com](http://HitachiVantara.com) | [community.HitachiVantara.com](http://community.HitachiVantara.com)

Contact Information  
USA: 1-800-446-0744  
Global: 1-858-547-4526  
[HitachiVantara.com/contact](http://HitachiVantara.com/contact)