



System Manager Unit (SMU) Hardware Reference

Notices and Disclaimer

Copyright © 2015 Hitachi Data Systems Corporation. All rights reserved.

The performance data contained herein was obtained in a controlled isolated environment. Actual results that may be obtained in other operating environments may vary significantly. While Hitachi Data Systems Corporation has reviewed each item for accuracy in a specific situation, there is no guarantee that the same results can be obtained elsewhere.

All designs, specifications, statements, information and recommendations (collectively, "designs") in this manual are presented "AS IS," with all faults. Hitachi Data Systems Corporation and its suppliers disclaim all warranties, including without limitation, the warranty of merchantability, fitness for a particular purpose and non-infringement or arising from a course of dealing, usage or trade practice. In no event shall Hitachi Data Systems Corporation or its suppliers be liable for any indirect, special, consequential or incidental damages, including without limitation, lost profit or loss or damage to data arising out of the use or inability to use the designs, even if Hitachi Data Systems Corporation or its suppliers have been advised of the possibility of such damages.

This document has been reviewed for accuracy as of the date of initial publication. Hitachi Data Systems Corporation may make improvements and/or changes in product and/or programs at any time without notice. No part of this document may be reproduced or transmitted without written approval from Hitachi Data Systems Corporation.

Document Revision Level

<i>Revision</i>	<i>Date</i>	<i>Description</i>
0.0	April 2015	First publication
1.0	June 2015	Updated SMU Removal and Replacement section
2.0	December 2015	Added Use an ssh session to the SMU Removal and Replacement section

Table of Contents

Introduction to the SMU400	2
SMU400 hardware	4
Introduction to the SMU300	5
SMU300 hardware	7
Supported server releases	7
Port usage and connectivity	8
Serial port (COM1 and COM2) connection settings.....	8
Laptop Serial/KVM Configuration.....	9
SMU Removal and Replacement	10
Obtain an SMU backup (if the original SMU GUI is NOT functional).....	10
Use an ssh session to retrieve a backup	11
Obtain an SMU backup (if the original SMU GUI is functional)	11
Configuring the Replacment SMU	11
Replacement of the original SMU	13
Perform a sanity check on the new replacement SMU	13

Introduction to the SMU400

The SMU400 is a 1U rack mounted device, used to manage the servers and clusters of the Hitachi NAS Platform and the Hitachi HUS File Module storage systems.

HDS does not support component replacement, and the entire SMU should be replaced in case of hardware failures.

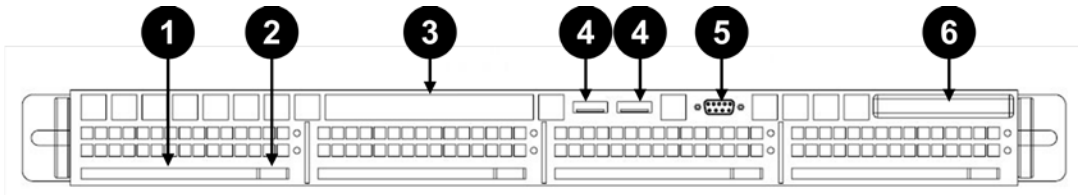
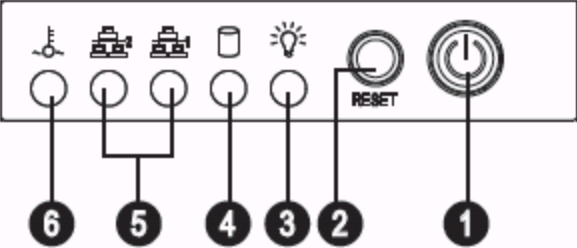

Figure 1: SMU400 Front View

Item	Description
1	Hard disk carrier.
2	Hard disk release button. Note: Just above the hard disk release button on the disk carrier, there are two LEDs that indicate hard disk status.
	<p>1. Hard disk activity 2. Hard disk failure</p>
3	DVD ROM.
4	USB Ports.
5	COM2, (serial connector B). COM2 can only be used at boot time, and is not available after the system has started. Note that COM1 (serial connector A) is on the rear panel.

Item	Description
6	<p>System buttons and LEDs.</p>  <p>1. Power 2. Reset 3. Power 4. Hard disk activity 5. LAN1 (ETH1) on the right and LAN2 (ETH0) on the left 6. Overheat or fan failure Flashes for fan or temp problems, and also flashes for power supply problems such as AC cable unplugged.</p>

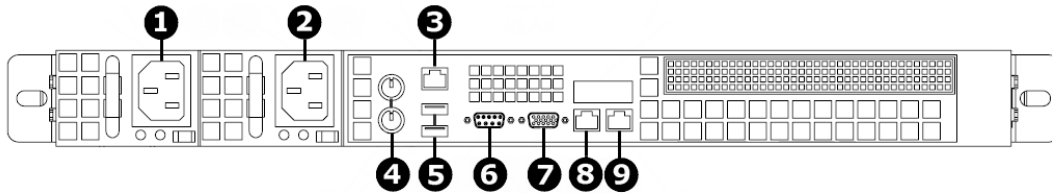

Figure 2: SMU400 Rear View

Item	Description
1	PSU 1.
2	PSU 2.
3	<p>IPMI Ethernet port (not used).</p> <p>Warning: IPMI functionality is provided as-is. The IPMI functionality for the SMU400 is not provided by HDS, and the use of IPMI with the SMU400 is not supported by the HDS Technical Resource Centre. Use at your own risk.</p>
4	Keyboard and mouse PS/2 ports (keyboard and mouse may be connected through USB ports).
5	USB ports.
6	COM1 (serial connector A). This port is preferred for serial communications, since it works at boot time and after boot time. Note that COM2 (serial connector B) is on the front panel.

Item	Description
7	VGA video out.
8	ETH1. (Note that the LAN1 LED on the front panel correlates to the ETH1 port.) LED indicators: <ul style="list-style-type: none"> • Off - No connection or 10 Mb/s • Green – 100 Mbps • Amber – 1 Gbps
9	ETH0. (Note that the LAN2 LED on the front panel correlates to the ETH2 port.) LED indicators: <ul style="list-style-type: none"> • Off - No connection or 10 Mb/s • Green – 100 Mbps • Amber – 1 Gbps

SMU400 hardware

The following table provides an overview of the hardware support offered by the SMU400:

Area	
Front	<ul style="list-style-type: none"> • Removable hard disk • Serial port (COM2) for use at boot time
Rear	<ul style="list-style-type: none"> • 2 PSUs • ETH0 port to the right of ETH1 port • ETH1 port to the left of ETH0 port • Serial port (COM1) • IPMI Ethernet port to facilitate remote KVM (no more need for physical access to an SMU). <p>Warning: IPMI functionality is provided as-is. The IPMI functionality for the SMU400 is not provided by HDS, and the use of IPMI with the SMU400 is not supported by the HDS Technical Resource Center. Use at your own risk.</p>
Processor and RAM	<ul style="list-style-type: none"> • Xeon E3 1225 • 4 cores * 4 hyperthreads • 3.2 GHz • 8 GB RAM DDR3
Mounting	<p>Quick release rails, fitting racks of 25.6-33.05 inch depth. (Note that rails from older SMUs cannot be used.)</p> <p>Refer to the <i>Hitachi NAS Platform and Hitachi Unified Storage System Installation Guide (MK-92HNAS015)</i> for more information.</p>

Introduction to the SMU300

The SMU300 is a 1U rack mounted device, used to manage the servers and clusters of the Hitachi NAS Platform and the Hitachi HUS File Module storage systems.

HDS does not support component replacement, and the entire SMU should be replaced in case of hardware failures.

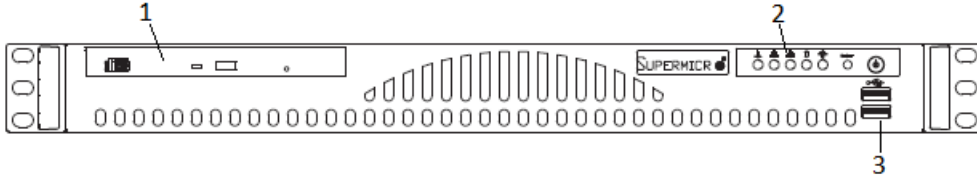

Figure 3: SMU300 Front View

Item	Description
1	DVD ROM.
2	System buttons and LEDs. <div style="text-align: center;"> </div> <ol style="list-style-type: none"> 1. Power 2. Reset 3. Power 4. Hard disk activity 5. LAN1 (ETH0) on the right and LAN2 (ETH1) on the left 6. Overheat or fan failure Flashes for fan or temp problems, and also flashes for power supply problems such as AC cable unplugged.
3	USB ports

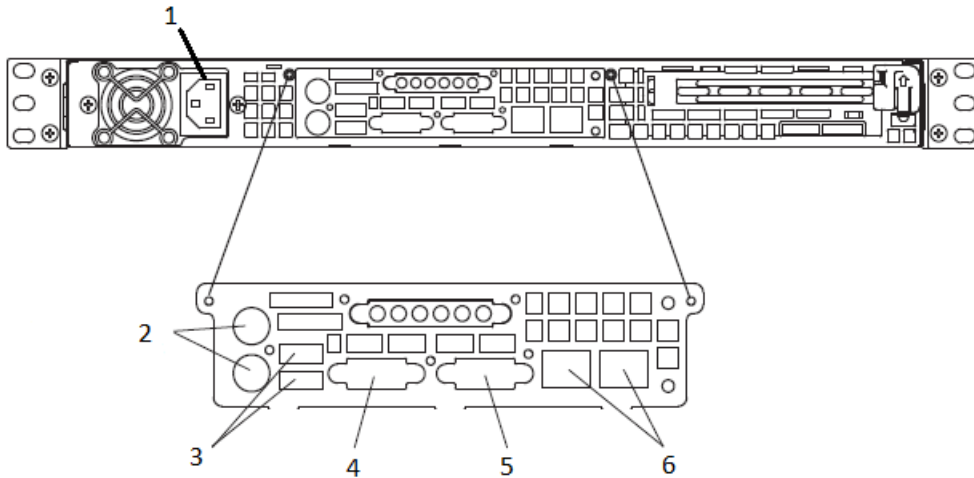

Figure 4: SMU300 Rear View

Item	Description
1	PSU.
2	Keyboard and mouse PS/2 ports (keyboard and mouse may be connected through USB ports).
3	USB ports.
4	COM1 (serial connector A). This port is preferred for serial communications, since it works at boot time and after boot time.
5	VGA video out.
6	<p>ETH0.(left) (Note that the LAN1 LED on the front panel correlates to the ETH0 port.)</p> <p>LED indicators:</p> <ul style="list-style-type: none"> • Off - No connection or 10 Mb/s • Green – 100 Mbps • Amber – 1 Gbps <p>ETH1.(right) (Note that the LAN2 LED on the front panel correlates to the ETH1 port.)</p> <p>LED indicators:</p> <ul style="list-style-type: none"> • Off - No connection or 10 Mb/s • Green – 100 Mbps • Amber – 1 Gbps

SMU300 hardware

The following table provides an overview of the hardware support offered by the SMU300:

Area	
Rear	<ul style="list-style-type: none">• PSU• ETH0 port to the right of ETH1 port• ETH1 port to the left of ETH0 port• Serial port (COM1)
Processor and RAM	<ul style="list-style-type: none">• Core2 E7500 Series• 4 GB RAM DDR2• 2.93 Ghz

Supported server releases

See *Hitachi NAS Platform, NAS Operating System 12.3 Release Notes* or later for the most current values.

SMU	CentOS Version	Supported Server Releases	Number of Supported Servers / Cluster	
			SMU 300	SMU 400
		HNAS OS		
SMU 8.1	4.8.1	7.0, 8.2	5	Not supported
SMU 10.1, 10.2	6.2	8.1, 8.2, 10.0, 10.2	5	5
SMU 11.x	6.2	8.1, 8.2, 10.2, 11.x	5	5
SMU 12.x	6.2	8.1, 8.2, 10.2, 11.x, 12.x	5	5

Port usage and connectivity

For serial (COM1 and COM2) port settings, see Serial port (COM1 and COM2) connection settings below. For all other connections, refer to the *Hitachi NAS Platform and Hitachi Unified Storage System Installation guide* (MK-92HNAS015) for more information.

Serial port (COM1 and COM2) connection settings

- Baud rate: 115200 (may need to set in terminal emulator application)
- Data: 8 bits
- Parity: None
- Stop bits: 1 bit
- Flow Control: None

Laptop Serial/KVM Configuration

1. Make a connection to the external SMU

Note: On newer notebooks, you will need a USB to serial dongle and a 9-pin DB9 null modem cable. This is the preferred method, as it will allow you to capture the output to a file when using a Putty serial connection.

- a. Open a SERIAL Putty session:

- i. Putty configuration

1. Select the Serial Radio Button
 2. Enter the COM port that your serial dongle is using
 3. Enter 115200 in the Speed box.
 4. Click on Serial in the Category Tree on the left
 5. Make sure the Speed is 115200
 6. Set the Data bits to 8
 7. Set the Stop bits to 1
 8. Set the Parity to None
 9. Set the Flow Control to None
 10. Click on Session in the Category Tree on the left
 11. Enter SMU serial (or similar in the Saved Sessions box
 12. Click the Save button

- ii. Turn on the putty session logging

1. Click on Logging from the Category Tree on the left
 2. Select "Printable output" in Session logging.
 3. Set the location for the putty output file
 4. In the section What to do if the log file already exists; select "Ask the user every time"
 5. Click on "Session" from the Category Tree on the left, which returns you to the Session window
 6. Click on the Save button

- b. KVM Connection - Connect a monitor, keyboard and mouse to the appropriate ports on the back of the SMU.

SMU Removal and Replacement

The following sections provide the procedure for removing and replacing the SMU.

HDS does not support component replacement, and the entire SMU should be replaced in case of hardware failures.

Obtain an SMU backup (if the original SMU GUI is NOT functional)

Perform the following steps to recover a backup file from a malfunctioning SMU (if you can get to a Debian Linux prompt).

Prerequisites

1. KVM or Laptop with putty installed
2. USB stick
3. Replacement SMU

Login to the SMU

1. Connect a KVM or Serial cable to the SMU
2. At the Login Prompt Login as username: *root* password: *nasadmin*

Connect and mount the USB stick

1. Connect the USB drive to a USB port on the SMU
2. Run the *fdisk -l* command. The last line in this command should show you the device name of the USB key (e.g. **/dev/sdb1**). This line should show a device that matches the size and configuration of the USB key
3. Enter *mount /dev/sdb1 /mnt*

Copy the SMU backup file to the USB stick (ie. *smu_01May15_010000.zip*)

1. Change to the backup directory of the SMU
 - a. *cd /var/opt/smu/archive/smu-backup/<ip address of the local SMU>*
2. List the SMU backup files
 - a. *ls -l*
3. Copy the SMU backup file to the /mnt directory (USB stick)
 - a. *cp /<latest SMU backup .zip file> /mnt*

Unmount the USB stick

1. Execute *umount /mnt*
2. Remove the USB stick from the old SMU
3. The USB stick can now be used to recover the SMU configuration to the Replacement SMU

Use an ssh session to retrieve a backup

As an alternative to copying the SMU backup file by using an usb stick, if you can get to the SMU with an ssh session then you can retrieve a backup to copy the backup files directly to your laptop.

1. Connect your laptop to the management switch.
2. Change the interface to **192.0.2.100**
3. Open WinSCP.
 - a) File Protocol: **scp**
 - b) Hostname: **192.0.2.1**
 - c) Username: **manager**
 - d) Password: **nasadmin**
 - e) Click **Login**.
 - f) Above the left pane, open the drop-down and navigate to the location where you want to store the backup.
 - g) In the right pane, click **..** multiple times to get to the root of the SMU file structure
 - a. Navigate through the file structure to `/var/opt/smu/archive/smu-backup/<smu public ip address>`
 - h) You will find multiple backup .zip files.
 - i) Click and drag them to the left pane.
 - j) Click **OK** to start the copy.
4. You now have the backup files on your laptop.

Obtain an SMU backup (if the original SMU GUI is functional)

1. On the original SMU, label all the cables.
2. Connect your laptop to the private management switch.
 - a. Configure the laptop ip address:
 - i. IP address 192.0.2.150
 - ii. Netmask 255.255.255.0
3. Open a web browser, navigate to 192.0.2.1 and logon as Username: *admin* Password: *nasadmin*
4. Back up the SMU.

Note: If managing a cluster, leave the original SMU powered up and cabled to provide quorum.

- a. In the GUI, navigate to **Home > SMU Administration > SMU Backup and Restore**
- b. Click the Backup SMU: *Backup* button
- c. Save the configuration file to a location on your computer
- d. Verify that the archive file opens

Configuring the Replacment SMU

1. Set up the new SMU in a staging area first.
2. Make a connection to the external SMU.
 - a. Serial Connection - Connect via Putty Serial (Serial Settings 115200, 8, N, 1, N) to the serial console port

Note: On newer notebooks, you will need a USB to serial dongle and a 9-pin DB9 null modem cable. This is the preferred method, as it will allow you to capture the output to a file when using a Putty serial connection.

- b. KVM Connection - Connect a monitor, keyboard and mouse to the appropriate ports on the back of the SMU

3. SMU Installation.

- a. Depress the red button on the front of the SMU to power the unit on

- b. Verify code level of the replacement SMU

- i. Login as Username: *root* Password: *nasadmin*

- ii. Check the SMU Version.

- 1. Type *smu-version*

```
[root@Angelmerc2 manager]# smu-version
System Management Unit (SMU) Version: 11.2.3319.02 Tue Jul 02, 2013 13:09:15 PDT
[root@Angelmerc2 manager]#
```

Note: SMU should be running the same firmware version or newer that supports the HNAS node SU. If it is not, then follow the procedure after configuring the SMU to upgrade to the latest version.

- c. If necessary, load same firmware version or newer that supports the HNAS node SU to the SMU via CLI.

- i. Equipment - USB flash drive

- 1. Latest SMU firmware iso file (SMUsetup_<filename>_hds.iso)
 - 2. SMU backup file generated in Step 5

- ii. Upgrade Procedure

- 1. It is assumed that the previous console session is still active
 - 2. Connect the USB drive to a USB port on the SMU
 - 3. Create a directory: *mkdir /mnt2*
 - 4. Enter *mount /dev/sdb1 /mnt2*
 - 5. Enter *cd /mnt2* (change to the */mnt2* directory)
 - 6. Copy the SMUsetup file from the USB to the */tmp* directory
 - a) *cp SMUsetup_<file_name>.hds.iso /tmp/*
 - b) *cp smu_date_stamp.zip /tmp/*
 - 7. Enter *cd /* (changes to the root directory)
 - 8. Enter *umount /mnt2* (unmounts the USB drive)
 - 9. Remove the USB drive

- d. Install the SMU Application

- i. Mount the SMU .iso file:

- *mount -o loop /tmp/SMUsetup_<filename>_hds.iso /mnt2*

- ii. Type */mnt2/autorun*

Note: The SMU installation may take up to 20 minutes to install, followed by a reboot. Make sure you have removed the USB drive prior to rebooting.

- e. Restore the SMU from the configuration backup of the old SMU:
 - i. Login to the console connection as Username: *root* Password: *nasadmin*
 - ii. Enter *cd /usr/local/bin* (Change to the */usr/local/bin* directory)
 - iii. Start the restore: *./smu-restore -f /tmp/<smu_date_stamp.zip>*

NOTE: The smu-restore process can take anywhere from 45 minutes to 2 hours. **Do not interrupt the process.**
 - iv. Enter *reboot*
- f. Once the SMU has rebooted, the logon ID displayed should be that of the old SMU.
 - i. Login to the console as Username: *root* Password: *nasadmin*
 - ii. Enter *ifconfig* (verify that the replacement SMU has the following ip addresses)
 1. eth1 - HDS management ip address (typically 192.0.2.1)
 2. eth0 - the customer management ip address
 - iii. Type *shutdown -h now* (this will power off the Replacement SMU)

Replacement of the original SMU

1. Move the Serial/KVM connection to the Original SMU.
2. Login as Username: *root* Password: *nasadmin*
3. Type *shutdown -h now* (this will power off the Original SMU).
4. Physically remove the original SMU and install the replacement SMU.

Perform a sanity check on the new replacement SMU

1. Move the Serial/KVM connection to the replacement SMU.
2. Plug the cables that were removed from the original SMU into the replacement SMU.
(**Note:** The Replacement SMU port locations may be different. For SMU 400 port locations, refer to Figure 2, and for SMU 200 or SMU 300 port locations, refer to Figure 4.)
3. Depress the red button on the front of the replacement SMU to power the unit on.
4. Login as Username: *root* Password: *nasadmin*
5. Execute *ifconfig* (eth0 should report the original customer IP address and eth1 should be 192.0.2.1).
6. Execute *smu-version* (verify the SMU version is the matching or latest version of firmware)
7. Logout by typing *exit*
8. Using the ethernet connection to the HNAS management switch, open an ssh putty session to the new SMU at 192.0.2.1
9. Login as Username: *manager* Password: *nasadmin*
10. Select the server (adminEVS) that you wish to manage from the menu (if more than one local server is present, repeat these steps for each server)

11. At the Bali prompt, execute `cluster-show` (verify that the cluster is Robust).

```
merc2c-2:$ cluster-show
Overall Status = Online
Cluster Health = Robust
Cluster Mode = Clustered
Cluster Name = merc2c
Cluster UUID = 3f0e11b8-f33f-11cd-9000-0b2a47ec12f4
Cluster Size = 2
  Node Name = merc2c-2
  Node ID = 2
Cluster GenId = 41
Cluster Master = Yes

merc2c-2:$
```

12. Execute `quorumd show` (verify that the SMU quorum device is configured).

```
merc2c-2:$ quorumd show
Quorum Device Name      = ANGELMERC2
Quorum Device IP Address = 192.0.2.133
Quorum Status           = Configured
Cluster Safe            = Yes
Quorum Master ID        = 2
Quorum Generation ID    = 41
merc2c-2:$
```

13. If the Quorum is NOT showing Configured then do the following:
- Execute `quorumd remove`
 - Execute `quorumd add 192.0.2.1`
 - Recheck the quorum status with `quorumd show`

Hitachi Data Systems

Corporate Headquarters

2845 Lafayette Street
Santa Clara, California 95050-2639
U.S.A.

www.hds.com

Regional Contact Information

Americas

+1 408 970 1000

info@hds.com

Europe, Middle East, and Africa

+44 (0) 1753 618000

info.emea@hds.com

Asia Pacific

+852 3189 7900

hds.marketing.apac@hds.com

MK-92HNMAS065-02

