

Hitachi Virtual Storage Platform E590, E790

93-03-2x

Installation Guide

This guide provides information and instructions for installing and setting up your Hitachi Virtual Storage Platform storage system.

© 2020 Hitachi, Ltd. All rights reserved.

No part of this publication may be reproduced or transmitted in any form or by any means, electronic or mechanical, including copying and recording, or stored in a database or retrieval system for commercial purposes without the express written permission of Hitachi, Ltd., or Hitachi Vantara LLC (collectively "Hitachi"). Licensee may make copies of the Materials provided that any such copy is: (i) created as an essential step in utilization of the Software as licensed and is used in no other manner; or (ii) used for archival purposes. Licensee may not make any other copies of the Materials. "Materials" mean text, data, photographs, graphics, audio, video and documents.

Hitachi reserves the right to make changes to this Material at any time without notice and assumes no responsibility for its use. The Materials contain the most current information available at the time of publication.

Some of the features described in the Materials might not be currently available. Refer to the most recent product announcement for information about feature and product availability, or contact Hitachi Vantara LLC at <https://support.hitachivantara.com/en-us/contact-us.html>.

Notice: Hitachi products and services can be ordered only under the terms and conditions of the applicable Hitachi agreements. The use of Hitachi products is governed by the terms of your agreements with Hitachi Vantara LLC.

By using this software, you agree that you are responsible for:

1. Acquiring the relevant consents as may be required under local privacy laws or otherwise from authorized employees and other individuals; and
2. Verifying that your data continues to be held, retrieved, deleted, or otherwise processed in accordance with relevant laws.

Notice on Export Controls. The technical data and technology inherent in this Document may be subject to U.S. export control laws, including the U.S. Export Administration Act and its associated regulations, and may be subject to export or import regulations in other countries. Reader agrees to comply strictly with all such regulations and acknowledges that Reader has the responsibility to obtain licenses to export, re-export, or import the Document and any Compliant Products.

Hitachi and Lumada are trademarks or registered trademarks of Hitachi, Ltd., in the United States and other countries.

AIX, AS/400e, DB2, Domino, DS6000, DS8000, Enterprise Storage Server, eServer, FICON, FlashCopy, GDPS, HyperSwap, IBM, Lotus, MVS, OS/390, PowerHA, PowerPC, RS/6000, S/390, System z9, System z10, Tivoli, z/OS, z9, z10, z13, z14, z/VM, and z/VSE are registered trademarks or trademarks of International Business Machines Corporation.

Active Directory, ActiveX, Bing, Excel, Hyper-V, Internet Explorer, the Internet Explorer logo, Microsoft, the Microsoft Corporate Logo, MS-DOS, Outlook, PowerPoint, SharePoint, Silverlight, SmartScreen, SQL Server, Visual Basic, Visual C++, Visual Studio, Windows, the Windows logo, Windows Azure, Windows PowerShell, Windows Server, the Windows start button, and Windows Vista are registered trademarks or trademarks of Microsoft Corporation. Microsoft product screen shots are reprinted with permission from Microsoft Corporation.

All other trademarks, service marks, and company names in this document or website are properties of their respective owners.

Copyright and license information for third-party and open source software used in Hitachi Vantara products can be found at <https://www.hitachivantara.com/en-us/company/legal.html>.

Installing your VSP E590 and VSP E790 storage system

Hitachi Virtual Storage Platform E590 and E790 storage systems are designed for self-installation, so you can install and set up your storage system for the first time without assistance from a Hitachi Vantara representative.

Make sure your data center meets all site preparation requirements before you install the storage system. If you are not using a Hitachi Universal V2 or Universal V2B rack, make sure the electrical specifications of your rack meet the power requirements of the storage system.

Step 1: Unpack the storage system

Procedure

1. Inspect all materials for signs of damage. If you see damage, discontinue the installation and contact your Hitachi Vantara representative.
2. Loosen the band around the cartons and open all boxes. Remove all packing materials, envelopes, and boxes from the cartons.
3. Retain all packing materials and cartons in case you need to transport or ship the storage system in the future.
4. Check the items you received against the packing list. If any items are missing or damaged, discontinue the installation and contact your Hitachi Vantara representative.
5. Place the keys for the front bezel in a safe place. You will need them to attach the bezel to the front of the controllers.
6. If your storage system arrived already factory-installed in a rack, skip step 2 and proceed to [step 3 \(on page 7\)](#).

Step 2: Install the storage system into a rack

Mount the controller into the Hitachi Universal V2 or Universal V2B rack or into a 4-post EIA 310-D compliant 19-inch rack with square mounting holes and rear-facing power distribution units (PDUs).

The following instructions describe how to install the controller into a Hitachi Universal V2B rack. For information about installing the controller in a third-party rack, see the documentation for that rack.

Note: The rail kit comes with pins that will fit racks with square or circular shaped holes. Please use the correct pin type for your rack.

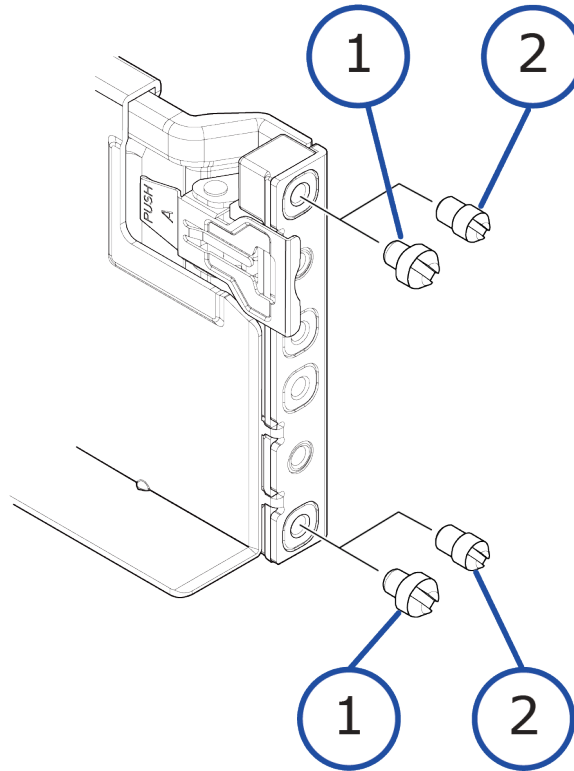

Number	Item
1	Pin for square holes
2	Pin for round holes

Before you begin

- Make sure the rack is secure and cannot fall over.
- Make sure the rack has one or more PDUs installed.
- Verify that all power cables are removed from the AC power receptacles on the rear of the controller.
- Install the rack stabilizers before mounting the storage system in the rack.

Procedure

1. Attach stopper with three screws on the rear side of the rail. Repeat step for both rails.

Step 2: Install the storage system into a rack

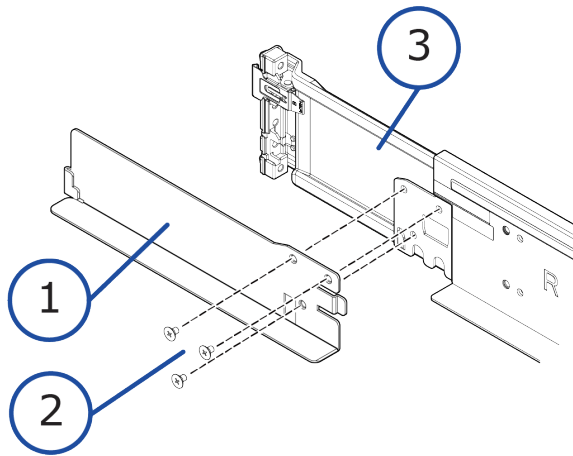

Number	Item
1	Stopper
2	Screws
3	Rail

2. Insert pins on the front and back of the rail into the holes on the front and back of the rack and hold in place using the rail clips. Repeat step for both sides.
3. Install the rear side of the rail with a washer and binding screw. Repeat step for both sides.

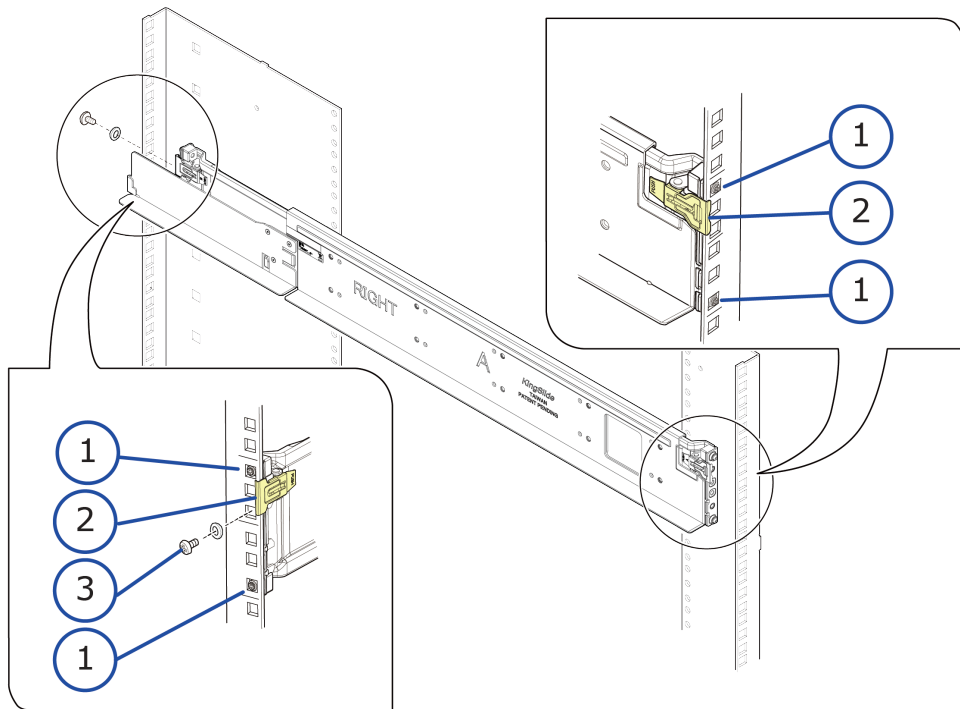

Number	Item
1	Pin
2	Clip
3	Washer and bind screw

- Position the controller so the front faces the front of the rack, and then slide the controller gently onto the rails. Stop sliding when the mounting flanges on the front of the controller touch the vertical face of the rack.



Note: Check the rear of the controller chassis to be sure the chassis is fit into the stoppers.

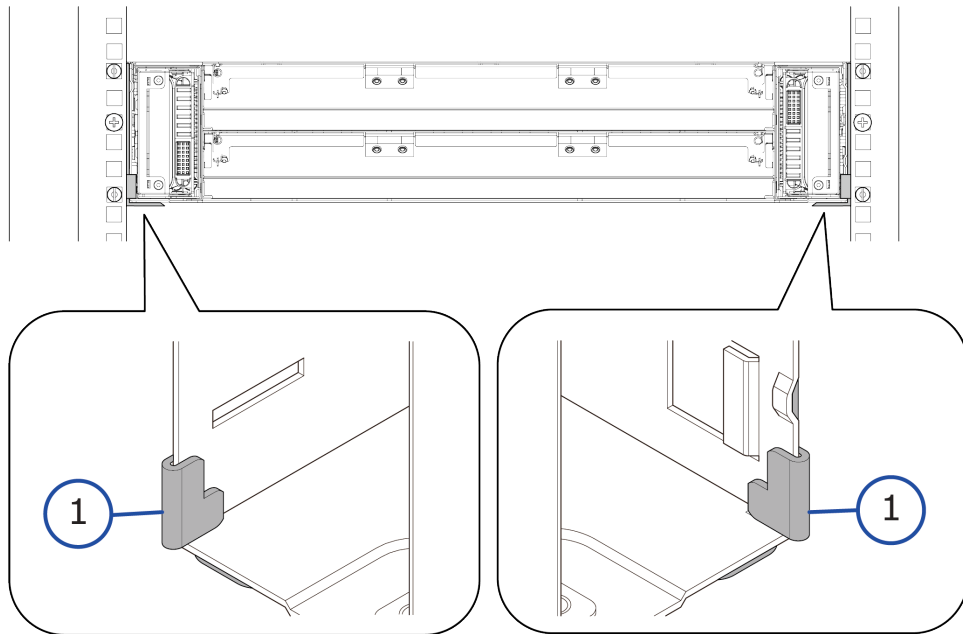

Number	Item
1	Stopper

- On the front of the controller chassis, attach the two bind screws and washers to each side of the rack.

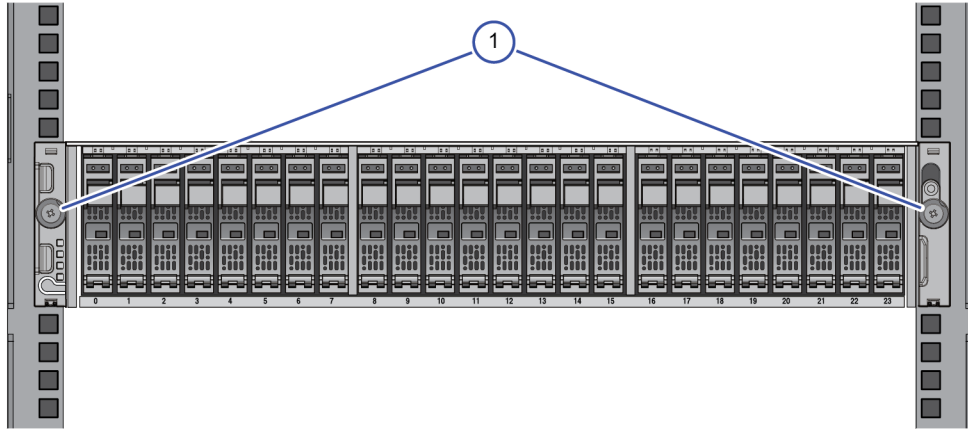

Number	Item
1	Bind screws

Step 3: Connect the storage system to power

The storage system's input voltage is auto-adjusting for 100-120 (+6%) / 200-240 (-11%) VAC, 50-60 Hz power connections. Power is provided through two power supplies, one per controller.

For best practice, establish power redundancy by routing each power supply to independent PDUs and then routing the PDUs to separate external power sources on different branch circuits. This arrangement enables the storage system to continue operating if AC power is lost to one power supply.

 **Note:** Multiple outlets in a PDU or power strip do not constitute an independent electrical source.

Procedure

1. Confirm that all power sources are off.
2. Connect an AC power cable to the power receptacle on the rear of each controller.
3. Route the power cables from each controller to separate PDUs, and then use the pre-installed tie wraps at each controller power receptacle to secure the power cables.
4. Connect the PDUs to separate external power sources on different branch circuits.

 **Note:** To prevent the storage system from being turned off by accident, make sure the external power sources are not controlled by a wall switch.

Step 4: Cable a management console

A customer-supplied computer is used to set up and manage your storage system.

Before you begin

- Obtain a Category 5 or better Ethernet cable.
- Obtain a customer-supplied Windows-based PC that will serve as the management console for setting up the storage system for the first time and, thereafter, to manage the storage system. The management console must have a supported web browser: Internet Explore version 11 or later, Chrome, or Firefox.

Procedure

1. Connect one end of the Ethernet cable to the management port on the rear of either controller.

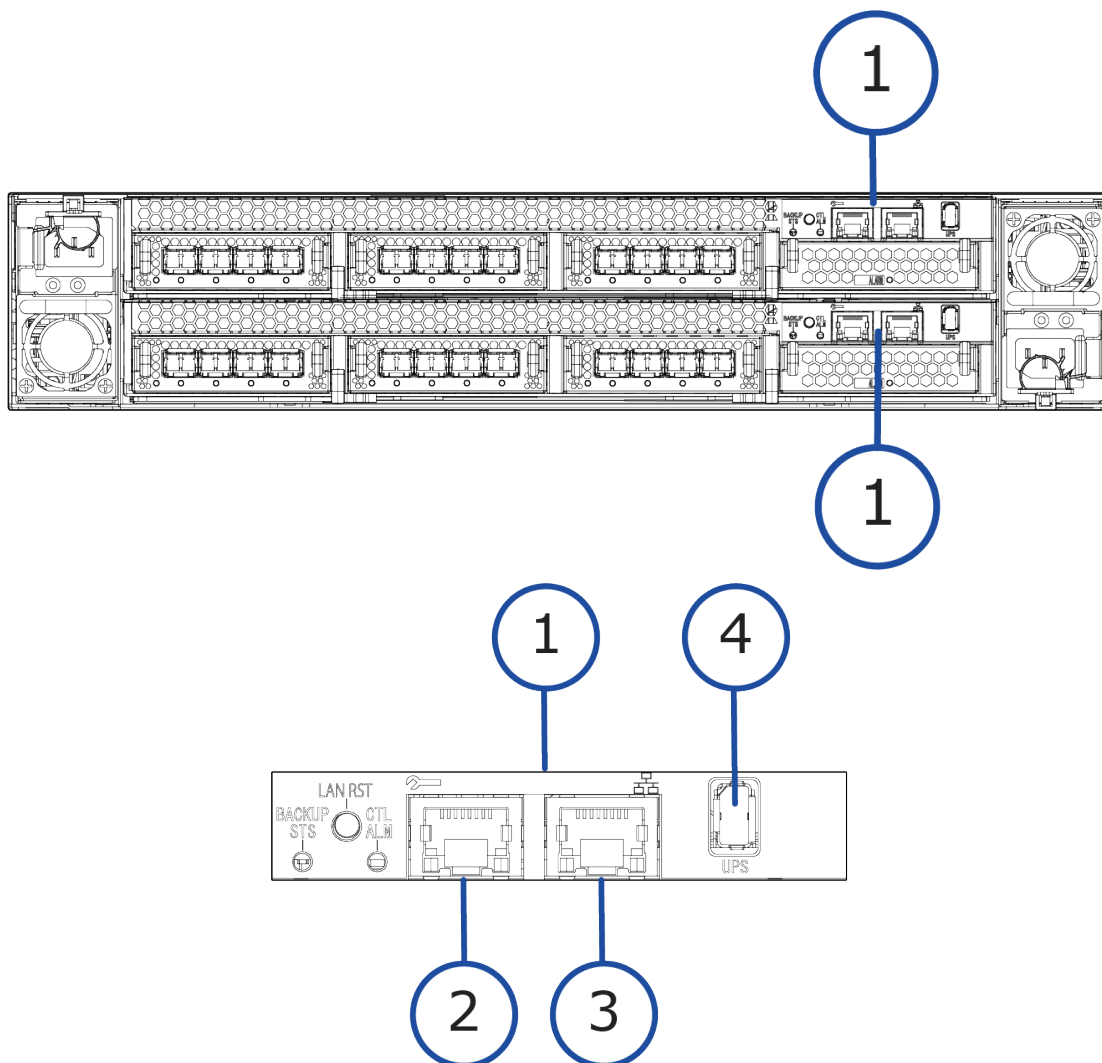

Number	Item	Description
1	LAN board	Networking board
2	LAN1	Connects to maintenance PC
3	LAN2	Connects to user's network
4	Uninterruptible power supply port	Not used.

2. Connect the other end of the cable to a management console.

Step 5: Power on the storage system

After connecting the management console to the storage system, you can power on the storage system.

Procedure

1. Power on the PDUs.
2. Confirm that the top (**POWER**) LED on the lower left front side of the controller is lit amber, as shown in the following figure. If the storage system has a drive tray, confirm that the **POWER** LED on the lower left front side of the drive tray is lit green.

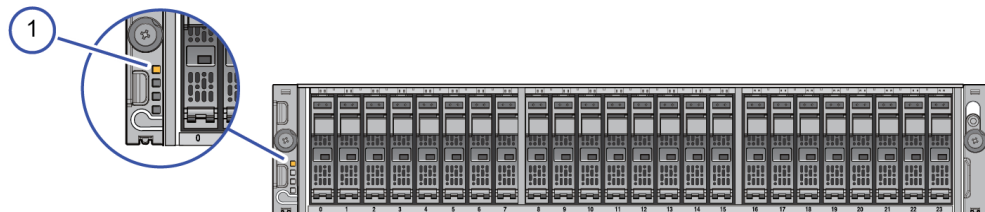

Item	Description
1	POWER LED on the front of the controller

3. If the front bezel is not attached to the front of the controller, attach it as follows:
 - a. Line up the two tabs on the left side of the controller with the two slots on the left side of the bezel.
 - b. Connect the bezel by sliding it on and swinging the bezel closed.
 - c. Use the key to secure the bezel to the front of the unit.
4. On the lower left front side of the controller, press and hold the **POWER ON/OFF** button until the **POWER** LED changes to green (about 3 seconds), and then release the button.

5. Wait for the green **READY** LED on the front of the controller to go on (approximately 13 minutes).



Note: If the **READY** LED does not go on after 30 minutes, contact customer support.

Step 6: Perform the initial setup

Initial setup of the storage system is performed using the Windows-based management console.

Preparing the storage system

Before you begin

Confirm that the Windows-based management console has an Internet connection and an installed version of one of the following web browsers: Internet Explorer version 11 or later, Chrome, or Firefox.

Procedure

1. Connect the management port on controller 1 and controller 2 to a management (non-production) network.
2. Configure the management console to use an IP address of 192.168.0.18 and a subnet mask of 255.255.255.0.

Next steps

Change the storage system's default password.

Changing the default password



Important: To protect the security of your device, change the default password immediately and retain the new password for your records.

Procedure

1. On your management console PC or laptop, open a web browser and enter the following IP address: 192.168.0.16
2. Enter the default user name and the default password, and then press the Enter key to log in to Hitachi Storage Advisor Embedded. Contact customer support for the default user name and password.

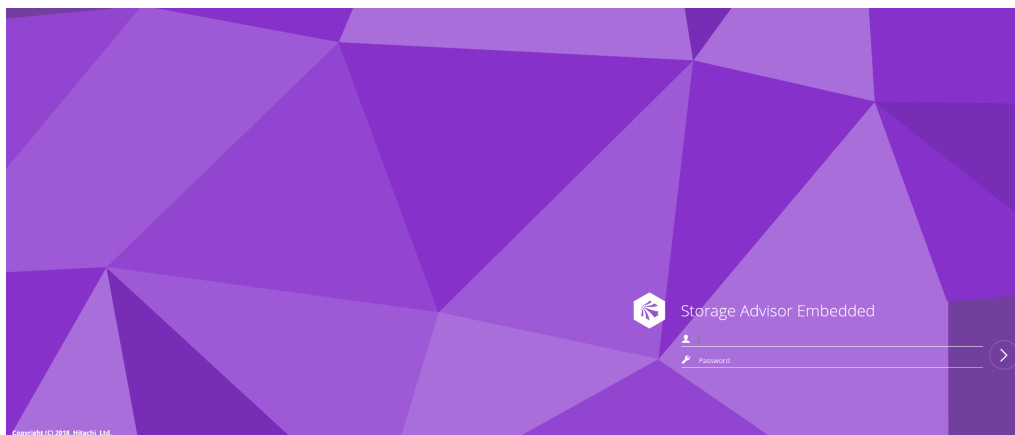

If the login window does not appear, check whether the browser is configured to allow pop-ups. If pop-ups are allowed, make sure the management console IP address is set to 192.168.0.18 and the subnet mask is set to 255.255.255.0. If the IP address and subnet mask are correct and pop-ups are allowed, but the login window does not appear, contact customer support.

3. In the top-right corner, click the gear icon, and then select **User Administration**.

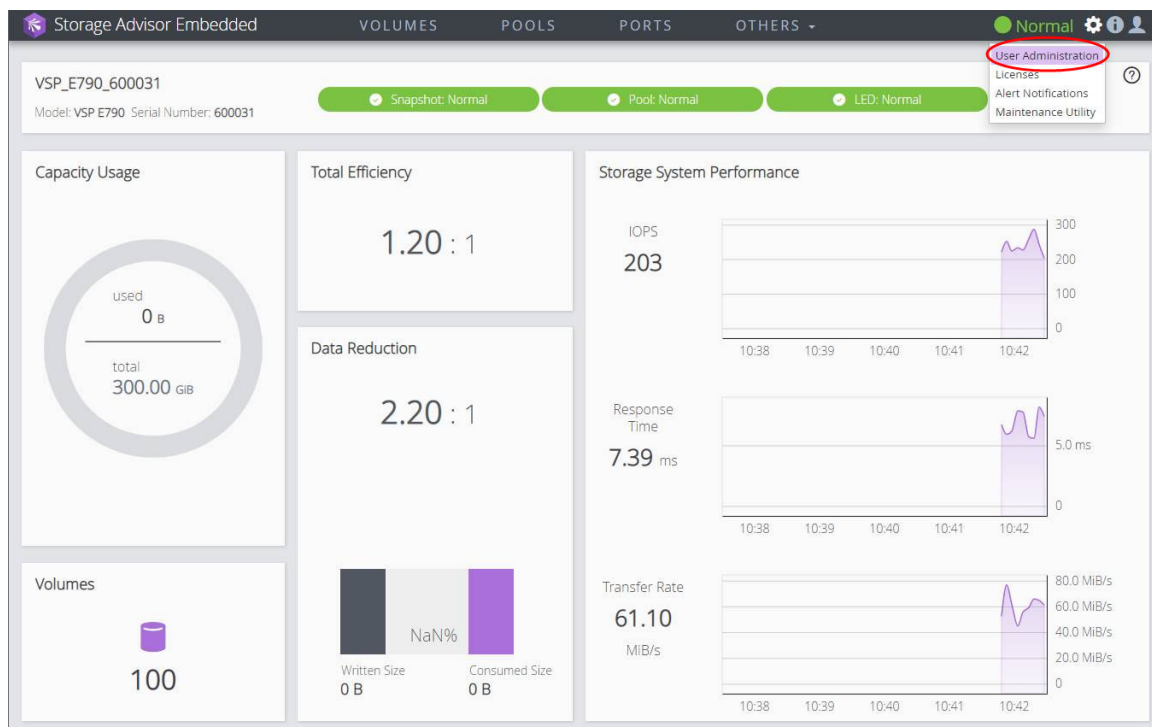

4. Click **Support Personnel Group**.

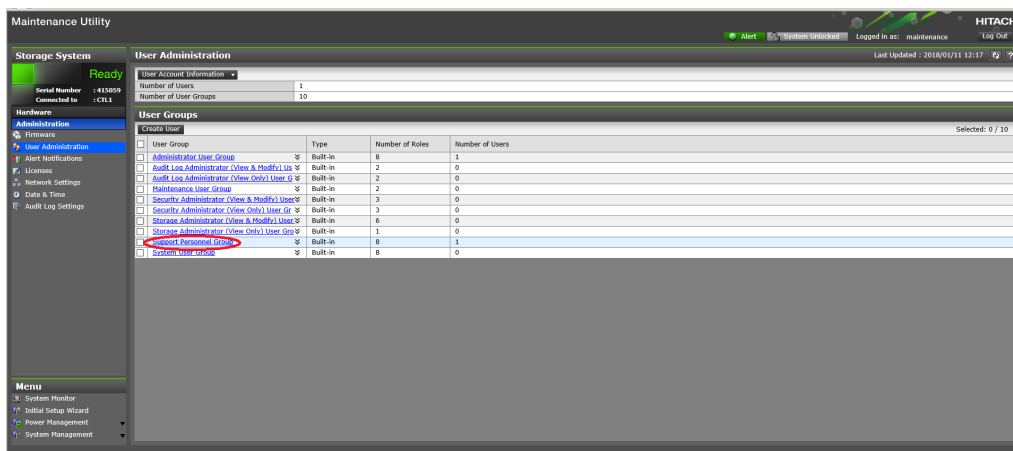

- On the **Users** tab, select the **maintenance** user check box if it is not already selected, and then click **Edit**.

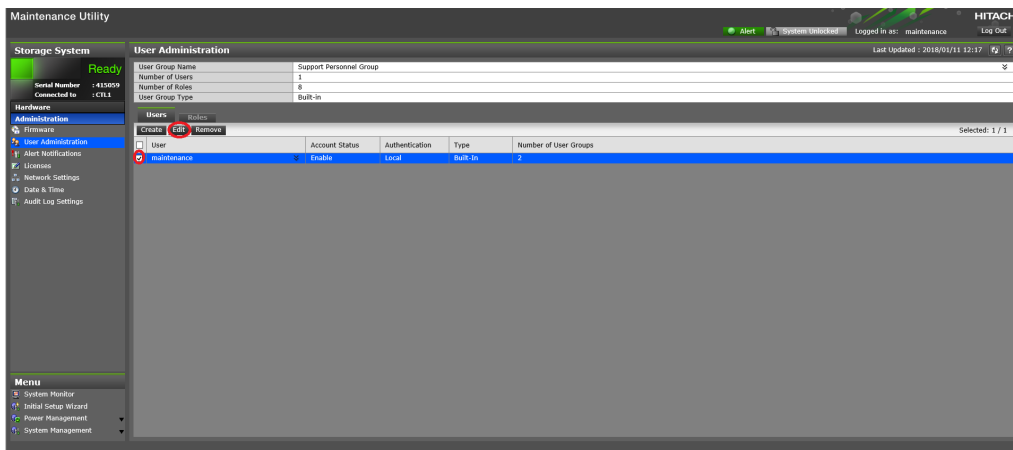

- Type the new case-sensitive password for the maintenance user in **New Password** and **Re-enter Password**. For security, each typed password character is masked with a dot.

Important: This password is required for storage system maintenance and for running the **Initial Setup** wizard. Record the new password for the maintenance user and keep it in a safe location.

Edit User

To update the user account information, edit the settings, and then click [Finish].

User Name: maintenance

Account Status: Enable Disable

Authentication: Local: New Password: [.....]
(6 - 256 characters)

Re-enter Password: [.....]

External:

User Groups			
<input type="checkbox"/>	User Group Name	Type	Number of Roles
<input checked="" type="checkbox"/>	Administrator User Group	Built-in	8
<input type="checkbox"/>	Audit Log Administrator (View & Modify) Use	Built-in	2
<input type="checkbox"/>	Audit Log Administrator (View Only) User Gr	Built-in	2
<input type="checkbox"/>	Maintenance User Group	Built-in	2
<input type="checkbox"/>	Security Administrator (View & Modify) User	Built-in	3

Selected: 2 / 10

Finish Cancel ?

7. Click **Finish**, and then click **OK**, **Apply**, and **Close**.

Next steps

Run the **Initial Setup** wizard.

Running the Initial Setup wizard

The **Initial Setup** wizard allows you to configure system information, date and time settings, and network settings.

The **Initial Setup** wizard settings are presented on three windows. Buttons at the bottom of each window allow you to apply or skip the settings on that window. If you skip settings, you can complete them later by running the **Initial Setup** wizard again. To display details about the settings in the windows, click the question mark icon in the bottom right.

Before you begin

Log in to Storage Advisor Embedded, and then open the maintenance utility by clicking the gear icon at the top-right corner and selecting User Administration.

Procedure

1. In the maintenance utility navigation tree, under **Menu**, click **Initial Setup Wizard**.



Tip: Initial Setup Wizard is near the bottom of the navigation tree. If you do not see this selection, scroll down the tree.

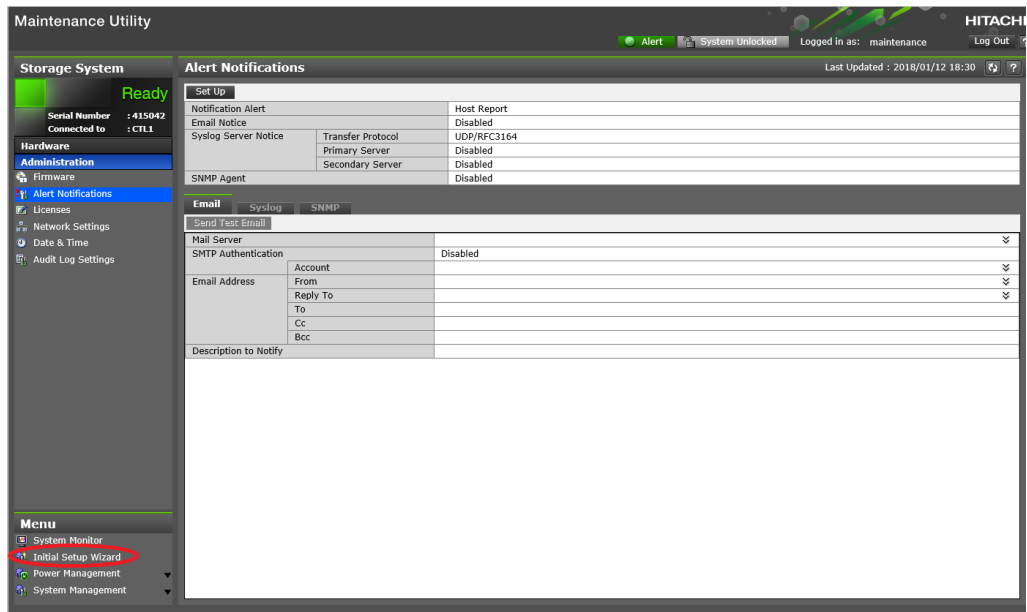

2. At the bottom, click **Skip this step** two times to bypass the **Set Up System Information** and **Set Up Date & Time** screens.
3. In the **Set Up Network Settings** screen, enter the IPv4 or IPv6 configuration settings for the production network to which the storage system will be connected. For example:

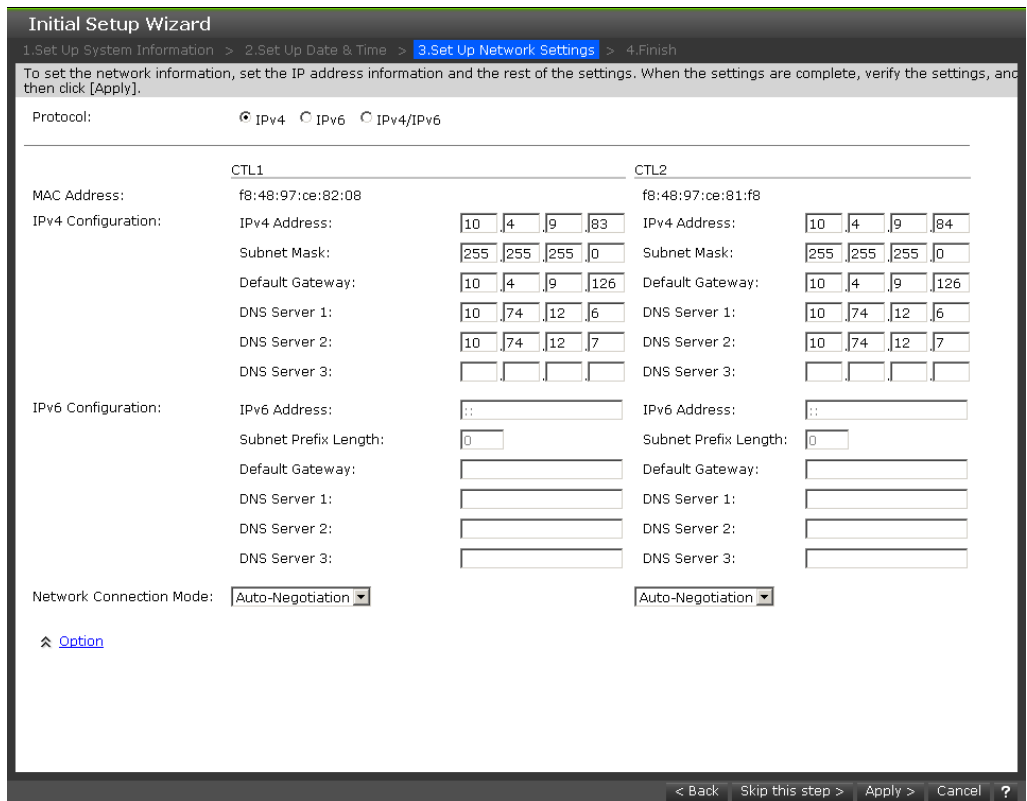

Setting	Description
---------	-------------

Protocol	IP addressing method to be used for configuring the storage system.
MAC Address	Read-only field that shows the MAC address for controllers 1 and 2.
IPv4 Configuration/ IPv6 Configuration	<ul style="list-style-type: none"> ▪ IPv4 Address: IPv4 address of the production network to which the storage system will be connected (IPv4 only). ▪ IPv6 Address: IPv6 address of the production network to which the storage system will be connected (IPv6 only). ▪ Subnet Mask: IP address mask that identifies the range of IP addresses in the subnet to which the storage system will be connected. ▪ Subnet Prefix Length: Subnet prefix length of the network to which the storage system will be connected (IPv6 only). ▪ Default Gateway: IP address of the default gateway to which the storage system will be connected. The gateway is the IP address of the router used to communicate outside the local subnet. ▪ DNS Server 1-3: If your configuration uses DNS to resolve IP addresses (for example, the IP address for the NTP server used with the storage system), enter up to three DNS IP addresses.
Network Connection Mode	Determines whether the storage system negotiates the speed and duplex mode automatically with the attached device. The default setting (Auto-Negotiation) connects the storage system at the highest speed and appropriate duplex setting supported by itself and the connected device.

Option	<ul style="list-style-type: none"> ▪ DNS Domain Name: IP address of the DNS server that will perform address resolution. ▪ DNS Search Order: Search domain names. Use the Up and Down buttons to order the domain names. ▪ Maintenance Port: Do not change these values. ▪ Internal Network: Do not change this value.
--------	--

4. Click **Apply**, and then click **Close**.
The system logs you out.
5. Remove the Ethernet cable from the management console and attach the cable to your production network. Leave the other end of the cable connected to the management port on the rear of the controller.
6. Connect one end of another Ethernet cable to the management port on the rear of the other controller. Connect the other end of the cable to your production network.
7. Wait 5 minutes for the maintenance utility to fetch the new IP addresses.
8. Open a web browser, and log in to Storage Advisor Embedded again. Use the new IP address you specified in the **Initial Setup** wizard and the new password you specified for the **maintenance** user.
9. In the top-right corner, click the gear icon, and then select **User Administration**.
10. In the maintenance utility navigation tree, under **Menu**, click **Initial Setup Wizard**.
11. Enter the system information, and then click **Apply and Next**.

Initial Setup Wizard

1. Set Up System Information > 2. Set Up Date & Time > 3. Set Up Network Settings > 4. Finish

To set the system information, enter the storage system name, the contact (optional), and the location (optional). When the settings are complete, verify the entries, and then click [Apply & Next].

Storage System Name:
(Max. 180 characters)

Contact:
(Max. 180 characters or blank)

Location:
(Max. 180 characters or blank)

Skip this step > Apply and Next > Cancel ?

Setting	Description
Storage System Name	Name used to identify the storage system. This name will appear in the maintenance utility, so use a name that is meaningful.
Contact	Name of the contact person associated with the storage system.
Location	Location of the storage system.

- Enter the date and time settings, and then click **Apply and Next**.

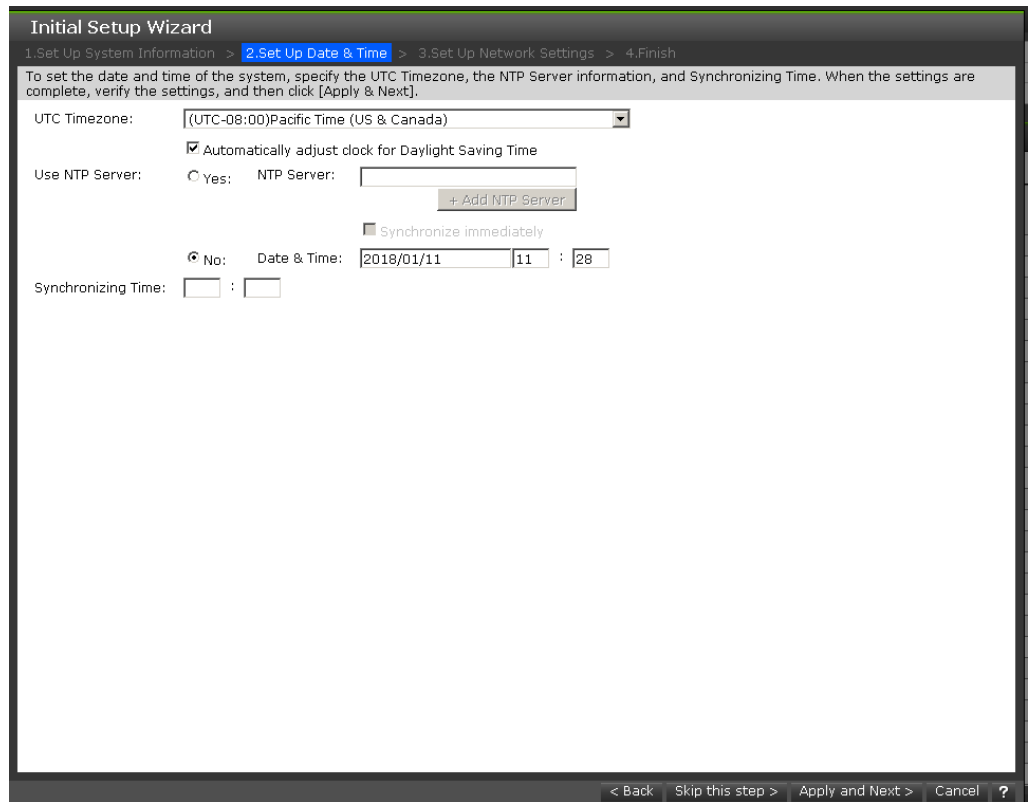

Setting	Description
UTC Timezone	Time zone in which the storage system is located.
Automatically adjust clock for Daylight Saving Time	If the time zone in which the storage system is located follows Daylight Saving Time, check this box to have the storage system automatically adjust its time twice a year.

<p>Use NTP Server</p>	<p>Determines whether the storage system time is synchronized with an NTP server.</p> <ul style="list-style-type: none"> ▪ Yes: Synchronize system time with an NTP server. Enter the IP address or domain name of the NTP server. To add more than three servers, click the + Add NTP Server button. To synchronize the system time to the NTP server time now, check Synchronize immediately. ▪ No: Do not synchronize system time with an NTP server. In Date & Time, enter the date and time that the storage system will use.
<p>Synchronizing Time</p>	<p>To synchronize the storage system time with the NTP server at a specific time, enter the time when the two will be synchronized.</p>

13. Confirm or change the network settings that you entered earlier in this procedure, and then click **Apply**.

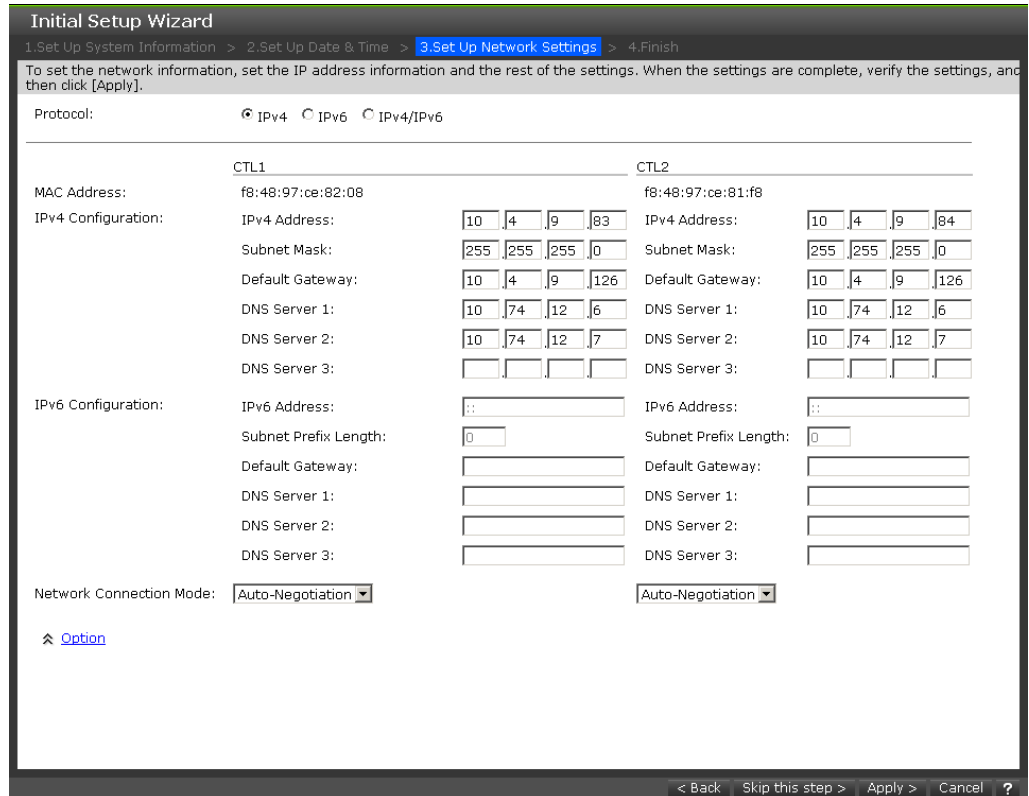

14. When prompted that initial settings are complete, click **Close**.

Next steps

(Optional) Configure syslog and SNMP notifications.

Configure syslog and SNMP notifications

Before you begin

Make sure the storage system is connected to your production network.

Procedure

1. In the navigation tree of the maintenance utility, under **Administration**, click **Alert Notifications**. Then click **Set Up** in the **Alert Notifications** pane on the right.



Note: Although a tab is provided for configuring email notifications, we recommend that you set up email notifications using Hitachi Remote Ops monitoring system.

The screenshot shows the Hitachi Maintenance Utility interface. On the left, the navigation tree is expanded to 'Administration' and then 'Alert Notifications'. The 'Set Up' button in the 'Alert Notifications' pane is circled in red. The main area shows the 'Alert Notifications' configuration page with tabs for 'Email', 'Syslog', and 'SNMP'. The 'Syslog' tab is selected, displaying fields for 'Mail Server', 'SMTP Authentication' (set to Disabled), 'Email Address' (with sub-fields for From, Reply To, To, Cc, Bcc), and a large text area for 'Description to notify'. The top of the interface shows 'Storage System Ready' and 'Alert System Unlocked'.

2. To configure the storage system to send notifications in syslog format, complete the settings in the **Syslog** tab. Then open a firewall port on your network for transferring syslogs.
3. To configure the storage system to send notifications as SNMP traps, complete the settings in the **SNMP** tab.
4. Click **Apply**, and then click **OK**.

Step 7: Make host connections

Host attachment tasks include configuring ports and preparing the host hardware and software for connection to the storage system. For information and instructions, see the host attachment preparation procedures in the *Open-Systems Host Attachment Guide*. You will also find the following resources helpful:

- For the latest interoperability and compatibility information about supported hosts and host attachment hardware, see the Hitachi Vantara [Interoperability Reports](#).
- For information about preparing your hosts for use with the storage system, see the documentation for the product.

Cabling Fibre Channel ports

! **Important:** For important information and instructions about connecting to hosts, refer to the *Open-Systems Host Attachment Guide*.

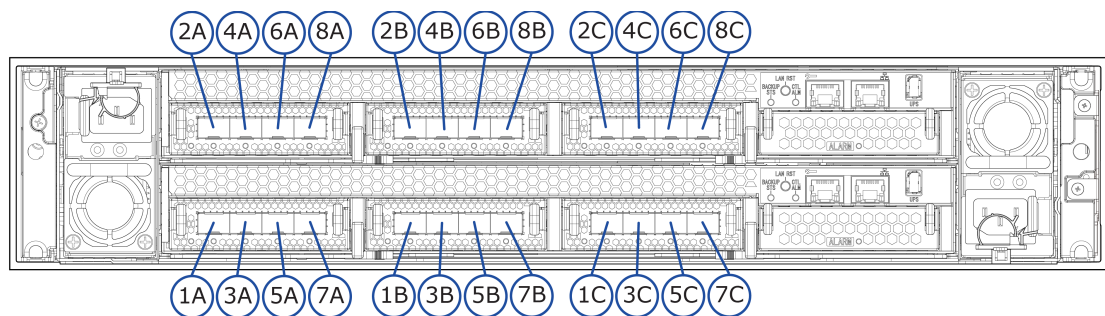

Before you begin

Make sure the storage system is connected to your production network.

Procedure

1. Connect the Fibre Channel data ports on each storage system controller to your Fibre Channel switch.
2. Connect your Fibre Channel switch to the Fibre Channel HBA card in each host computer or server.

Cabling iSCSI ports

Each controller supports 10-gigabit Ethernet copper (RJ-45) or optical (fiber) iSCSI connectivity to your data network.

! **Important:** For important information and instructions about connecting to hosts, refer to the *Open-Systems Host Attachment Guide*.

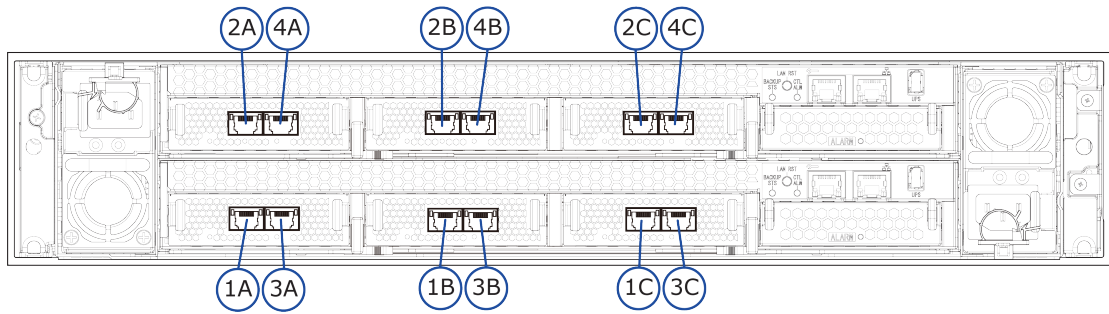

Before you begin

Make sure the storage system is connected to your production network.

Procedure

1. Using the appropriate cable, connect the iSCSI data ports on each storage system controller to your Gigabit Ethernet network switch.
2. Connect your Gigabit Ethernet network switch to the NIC or HBA card in each host computer or server.

Step 8: Register your storage system with Hitachi Vantara Support

If you do not already have an account on the [Support Website](#), you will need to [register](#). Otherwise, you will not be able to download and install the Hitachi Remote Ops monitoring system, and you will encounter delays in getting your storage system running and supported.

Before you begin

- [Register](#) an account on the Support Website.

Procedure

1. Locate the product serial number (labeled **MFG. NO.**) on the rear of the controller. You will need this number to register your storage system.
2. Open a web browser on your PC or mobile device.
3. [Log in to the Support Website](#), and follow the instructions to [register](#) your storage system. If you have previously registered Hitachi Vantara products, you can add [an additional site](#).

Step 9: Install Hitachi Remote Ops monitoring system

Hitachi Remote Ops monitoring system monitors your storage system and notifies Hitachi Vantara when assistance is required. Hitachi Remote Ops runs on Windows, Linux, and Solaris operating systems.

Before you begin

- [Log in to the Support Website](#). If you do not already have an account, you will need to [register](#). When registering, you will be asked for information about the product you own. For Product Name, enter VSP E Series. Locate your product serial number, which is labeled MFG. NO. on the rear of the controller.
- Obtain the Site ID for the location at which the storage system is installed. If you do not see your site listed, you will first need to [add the site](#).

Procedure

1. Download the [Hitachi Remote Ops](#) system software and documentation.
2. Open the *Hitachi Remote Ops Installation Guide*, and follow the installation instructions.
3. After you configure Hitachi Remote Ops with the appropriate Site ID, open a [case on the Support Website](#) to let us know that your system is installed and that the Hitachi Remote Ops monitoring system is enabled.

Installing Hitachi Remote Ops completes the self-installation of your storage system.

Where to go from here

After concluding the self-installation successfully, perform the following post-installation activities.

Configure the storage system for the first time

After you complete the self-installation of your storage system, configure the storage system to suit your requirements using your choice of embedded interfaces, Ops Center Administrator, Command Control Interface, or REST API.

For more information, see the [user documentation](#).

Read the release notes

Your storage system undergoes constant development and improvement.

Each time your storage system's firmware is updated, read the [release notes](#). The release notes provide important information about new features and functions as well as bug fixes.

Read the latest technical bulletins

Technical bulletins are provided to communicate technical information about your storage system and to assist you with additional information about the proper use, handling, and solving of technical issues.

You can [subscribe to receive technical bulletins](#), and then you can [access technical bulletins](#) on Hitachi Vantara Support Connect.

Support

The following resources provide additional information about the storage system:

- [Support Connect home page](#)
- [Product interoperability](#)
- [Hitachi Vantara Community](#)

Hitachi Vantara



Corporate Headquarters
2535 Augustine Drive
Santa Clara, CA 95054 USA
HitachiVantara.com | community.HitachiVantara.com

Contact Information
USA: 1-800-446-0744
Global: 1-858-547-4526
HitachiVantara.com/contact